

100 kW MODULAR LINEAR ACCELERATOR FOR INDUSTRIAL APPLICATIONS WITH ELECTRON ENERGY OF 7.5–10 MeV

A.A. Bryazgin*, V.L. Auslender, K.N. Chernov, V.G. Cheskidov, B.L. Factorovich, V.A. Gorbunov, I.V. Gornakov, G.I. Kuznetsov, I.G. Makarov, N.V. Matyash, G.N. Ostreiko, A.D. Panfilov, G.V.Serdobintsev, V.V.Tarnetsky, M.A. Tiunov, A.A. Tuvik, Budker INP, Novosibirsk, Russia

Abstract

At Budker INP SB RAS, a single module for a new 100 kW industrial accelerator with electron energy of 7.5–10 MeV has been successfully tested in pulsed operating regime. The accelerator operates at 176 MHz, expected wall plug to electron energy efficiency is 25–30%. The paper presents the accelerator concept together with simulation results for the accelerating structure, beam injection and dynamics.

The obtained structure electron efficiency of 67% and average electron beam current are close to the expected values. Improvements of beam transportation and energy spectrum due to the injection regime optimization were experimentally proven. The results obtained are discussed.

INTRODUCTION

A new modular high-energy (up to 10 MeV) and high-power (up to 100 kW) multi-gap accelerator has been developed by BINP to widen the range of irradiated products by the use of both e-beam and X-ray irradiation modes. The accelerator keeps all basic features of ILU type accelerators, such as internal beam injection and self-excited RF power source [1]. This work will allow us to create a new family of reliable simple RF accelerators, destined mainly for sterilization and pasteurization markets. Also they may make good replacement for ⁶⁰Co sources.

ACCELERATOR CONCEPT AND BLOCK DIAGRAM

Figure 1 presents the block diagram of the high-power industrial accelerator ILU-14. The main accelerator components are: triode electron gun, accelerating structure with 7 accelerating cavities, two-stage active oscillator, RF power inputs, and modulators. ILU-14 accelerator has some features which distinguish it from existing linear accelerators.

The first feature is the use for electron acceleration of a multi-cell low-frequency accelerating structure with on-axis coupling cavities, which operates in standing wave mode. The structure is driven by active oscillator based on five high-power triodes GI-50A. Use of such vacuum tubes provides the high plug-to-electron beam power efficiency.

* a.a.bryazgin@inp.nsk.ru

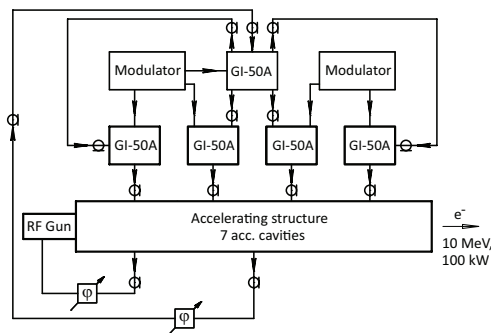

Figure 1: ILU-14 accelerator block diagram.

The second feature of the low-frequency accelerator is the possibility to use a triode RF gun as electron source. The gun is placed directly into the first accelerating gap. The narrow energy spectrum of the high-power electron beam required for efficient electron beam power transformation into X-rays and almost lossless transportation of the beam through the structure is provided by applying an additional RF voltage to the cathode-grid gap of the gun.

The third feature is the use of two-stage generator with feedback loop closed via the accelerating structure. Thus there is no need in frequency (thermo) stabilization of the structure or generator that simplifies the generator and accelerator control system.

The accelerator can operate in both e-beam (electron energy up to 10 MeV) and X-ray (electron energy up to 7.5 MeV) modes at the same average output electron beam power of 100 kW.

ACCELERATOR 5 MEV PROTOTYPE

ILU 14 has specially designed modular structure of the RF system and accelerating structure that allowed us to carry out the tests of all the main accelerator units at 5 MeV accelerator prototype. The prototype block diagram is presented in Fig.2. It contains the accelerating structure with five accelerating cavities (Fig.3), two single-stage generators based on GI-50A triodes, and a modulator, i.e. modules used in ILU-14 accelerator. The triode gun placed at the front wall of the first accelerating cavity (Fig.1) serves as electron source. RF power from two active oscillators is transferred via two feeders of 2λ length to both power inputs to be accumulated in the accelerating structure. Some

part of the power (about 300 kW) is extracted from the accelerating structure via the feedback loop to provide the positive feedback with the active oscillator. Then the power is transmitted through the extendable coaxial phase shifting line and enters the 3 dB circular bridge to be divided in half; halved powers are applied to GI-50A based stages. The modulator of ILU-10M accelerator [2] provides pulsed anode voltage amplitude of 30 kV with duration of 450 μ s. The pulse repetition rate is up to 35 Hz.

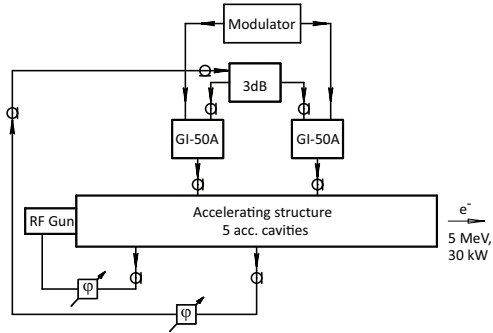

Figure 2: 5 MeV accelerator prototype block diagram.

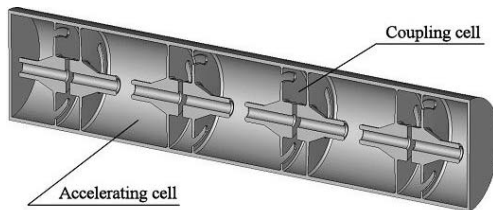

Figure 3: Accelerating structure of the prototype.

The prototype was manufactured at BINP workshop and tested in pulsed mode in 2008. The test results allowed us to prove and measure the following:

- a) accelerating structure electric strength by modeling the accelerating rate that corresponded to ILU-14 operation conditions (7.5 MeV and 10 MeV);
- b) accelerating structure cooling system efficiency;
- c) obtaining the required pulsed beam current from the RF gun;
- d) beam transmission coefficient and energy spectrum;
- e) serviceability of RF system elements (power inputs, feeders etc.).

HOT TESTS OF 5 MEV ACCELERATOR PROTOTYPE

Accelerating structure RF conditioning and tests

The accelerating structure coupling frequencies were measured by a network analyzer, the coupling constant 0.078 was determined from the dispersion curve. The measurement results were in good agreement with 3D simulation by CST Microwave Studio [3]. The simulation and

measurement results for the accelerating structure main parameters are listed in Table 1.

Table 1: Prototype accelerating structure parameters

Acc. structure parameter	Simulations	Measurements
Frequency, MHz	176.3	176.26
Quality factor	22000	21000
Transit time factor	0.986	—
Effective impedance, Ω	826	—
Shunt impedance, $M\Omega$	~ 18	17.3

The accelerator prototype general view is shown in Fig. 4.

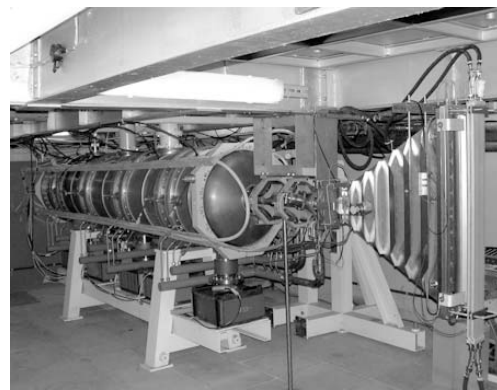

Figure 4: Accelerating structure with beam scanning system.

It took three hours of RF conditioning at pulse repetition rate of 1–25 Hz to overcome the RF discharge (multipactor). The accelerating voltage amplitude of 7.5 MeV was reached at 5 MeV module (five accelerating cells) for two hours. So, the accelerating structure with six full accelerating cells will have enough electric strength for electron acceleration up to 10 MeV. Table 2 presents the simulated parameters of the accelerator for energy of 7.5 MeV and 10 MeV with power of 100 kW. The accelerator is based on one-and-half accelerating structure modules (seven accelerating cavities).

Table 2: 100 kW ILU-14 accelerator parameters

Variant	1	2
Generator tube	5×GI-50A	5×GI-50A
Energy, MeV	10	7.5
Acc. structure efficiency, %	61	77
Total efficiency, %	26	32

The accelerating structure cooling system efficiency was experimentally proven. The structure was driven by pulsed power which corresponded to average power of 10 kW. The water discharge was 30 l/h. i.e. ten times lower than in

operating regime. The time diagram of the water temperature gradient in the water cooling system was measured, the steady temperature difference was 3 °C.

Then the accelerating structure coupling with the feeders was optimized for accelerator operation with pulsed electron currents of about 600 mA. The total RF power transmitted through two power inputs exceeded 4 MW at constant component of current pulse of 600 mA and accelerated electron energy of 5 MeV.

Electron beam transportation

Measurements of beam current from the cathode and at the structure output (the Faraday cup was installed at 1150 mm distance from the accelerator output flange) were carried out to optimize the beam transportation. The experiments were done with no additional RF voltage and with additional RF voltage of operating frequency applied to the gun cathode. The required beam current from the cathode was provided by the feedback system.

Beam passing through the structure without additional RF voltage was measured at 80%, and with additional RF voltage applied — at 96% level. The results are in good agreement with numerical simulations done for the beam injection and dynamics in the accelerator. At the optimal amplitude and phase of additional RF voltage applied to the cathode-grid gap, the pulsed current from the cathode reached 600 mA at 96% of beam passing.

The accelerator prototype operated at the maximum possible pulse repetition rate with additional RF voltage applied to the cathode-grid gap. The output device with linear beam scanning system along the window with release into atmosphere through titanium foil was used. The beam was thrown into the water cooled aluminum collector. Quadruple lens doublet was installed in front of linear scanning system magnet to form the beam transverse size of 20–30 mm on the foil surface.

The beam power measured by calorimetric method was 33 ± 2 kW at accelerated current pulse amplitude at the collector of 476 mA (injection current from the gun cathode of 500 mA), pulse duration of $420 \mu\text{s}$, and pulse repetition rate of 35 Hz.

Electron beam energy spectrum measurements

Accelerated electron energy was measured with magnetic spectrometer with non-uniform magnetic field ($n=0.5$). The value corresponded to the maximum spectral distribution was accepted as accelerated beam energy.

Results of 300 mA beam energy spectrum measurements proved that applying additional RF voltage (0.7 kV) increased and shifted the output current maximum at the spectrometer output to higher energies area. According simulations, that takes place due to current micro-pulse injection at the earlier (optimal) accelerating field phases.

Electron beam transverse size measurements

Beam spot size measurements were carried out by burning a hole in the 0.22 mm thickness foil. The foil was installed before the Faraday cup at 1150 mm distance from the prototype output. Experiments were carried out in two regimes — with no additional RF voltage on the gun cathode, and with additional RF voltage of operating frequency, in both cases the pulsed current from the cathode was 200 mA. The beam exposure time at the foil was chosen at about 2 minutes that was enough to obtain the steady state beam current at the Faraday cup.

Figure 5 presents the simulated beam current density profile at 1150 mm distance from the accelerating structure output together with the photograph of the foil burned by the 200 mA beam. The beam halo is clearly seen on the photo, so the measurement results are in good agreement with the simulations. The beam has the maximal transverse size in the dimension orthogonal to the grid slots as it was predicted by simulations.

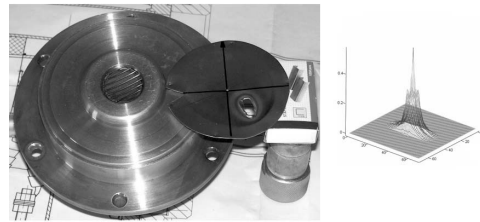

Figure 5: The foil burned by the beam. To the right: simulated electron beam transverse density distribution at the foil plane (about 1150 mm from the accelerator prototype output).

CONCLUSION

The prototype of high-power industrial electron accelerator ILU-14 has been successfully tested in pulsed mode at BINP SB RAS. The results obtained proved the possibility to create the series of linear accelerators with electron energy up to 10 MeV and beam power up to 100 kW on the base of RF modules designed by BINP. Rather narrow accelerated electron beam energy spectrum makes it possible to use the accelerators in both e-beam and X-ray modes that widen their field of application. Also, accelerators of that type may be a good replacement for ^{60}Co sources.

REFERENCES

- [1] V.L. Auslender et al., Industrial electron accelerator type ILU. Problems of Atomic Science and Technology, 3, 2006, pp.165–167.
- [2] V.L. Auslender et al., Electron accelerator for energy up to 5.0 MeV and beam power up to 50 kW. Proceedings of the 19-th Russian Particle Accelerator Conf. (RuPAC 2004). Dubna, JINR, 2005, pp.116–120.
- [3] <http://www.cst.de>.