

INDUSTRIAL ELECTRON ACCELERATORS TYPE ILU

V. L. Auslender, V.V. Bezuglov, A. A. Bryazgin, V.A. Gorbunov, V.G. Cheskidov, I.V. Gornakov, B.L. Faktorovich, V. E. Nekhaev, V.S. PodobaeV, A. D. Panfilov, A.V. Sidorov, V. O. Tkachenko, A.F. Tuvik, L.A. Voronin, BINP, Novosibirsk, Russia

Abstract

The report describes ILU type industrial electron accelerators. It describes their main parameters, design, principle of action, electron beam extraction devices, wide set of auxiliary equipment for various technological processes and ways of their usage.

INTRODUCTION

The pulse nature of the generated electron beam (their main difference from the widely used high voltage accelerators generating continuous electron beam) permits to adapt ILU machines easily to technological processes requiring formation of an irradiation zone with a complex configuration. The most bright example of such process is the irradiation of polymer insulation of cables and thermoshrinkable tubes. In this case the usage of 4-sided irradiation permits sharply to raise the productive rate of process, to improve quality of production and to expand the nomenclature of treated products without increase of electron energy. The ILU machines designed and produced in the Institute cover the energy range from 0.6 MeV to 5 MeV, and the maximum beam power is 50 kW.

Main parameters of the machines are given the Table 1. The main activity field of ILU Laboratory of BINP is the development, manufacturing and supply of the ILU accelerators for industry. Up till now more than 50 machines were installed, about 30 of them are installed abroad. The ILU machines are successfully working in the industrial lines in Korea, China, India, Italy, Poland, and other countries.

Table 1: Main parameters of the ILU accelerators.

PARAMETERS	ILU-6	ILU-8	ILU-10	ILU-12 Proj.
Energy of electrons, MeV	1.2-2.5	0.6-1.0	2.5-5.0	4.0-5.0
Average beam power (max), kW	20	25	50	300
Average beam current (max), mA	20	30	15	60
Power consumption, kW	100	80	150	700
Accelerator weight, tons	2.2	0.6	2.9	5

- Single-resonator ILU type accelerators have simple design, hence they are reliable, have low cost, and is easy to maintain. The used generator

scheme with self excitation and pre-excitation allowed us to provide the absolute stability of the RF system.

- Placing the electron gun directly into the accelerating gap with using the adjustable cathode voltage shift allows us to adjust the beam pulse current and so the average power within the wide range of values.
- In ILU 10 the additional RF voltage of the operating frequency with the phase shift relative to the accelerating voltage is applied to the cathode-grid gap, that allowed us to greatly decrease the accelerated beam energy spread.

ACCELERATOR ILU-6

The base model of the family is ILU-6. This machine has rather high parameters at modest dimensions and can be used for wide spectrum of technological processes. A principle of high-voltage acceleration is used in majority of modern accelerators, i.e., the energy of electrons corresponds to the voltage generated by the rectifier. The industrial accelerators type ILU are the exception of this rule. A principle of acceleration of electrons in the gap of HF resonator is used in the ILU machines. Such accelerator does not contain details, potentials of which with respect to the ground is comparable to accelerating voltage. So the complex high-voltage units (accelerating tubes, sections of rectifiers and etc.) which are damaged by the occasional discharges are not used in ILU machines. And so there is also no necessity to use insulating gas and high-pressure vessels. Use of a principle of high-frequency acceleration has allowed to create rather simple design of the machine having modest dimensions and weight. As a result the machine can be placed inside the hall of the smaller dimensions compared to the halls for high-voltage accelerators having the same parameters.

Figure 1 represents the accelerating system of the accelerator ILU-6 for explanation of a principle of action of the ILU machines. The accelerating system consists of copper toroidal resonator 1 placed inside the vacuum tank 2. The resonator consists of top and bottom halves, on the internal protrusions of which the electrodes forming an accelerating gap are installed. The top electrode has a built-in control grid. The cathode unit is mounted on this electrode on the insulator, and together with the grid it forms an electron injector (gun). The bottom electrode and the injector together form the accelerating system. The current of a beam of accelerated electrons is controlled by varying the value of positive bias on cathode concerning the grid. To suppress the

high-frequency resonance discharge in resonator the bottom half of it is installed on insulators and the bias voltage is passed on it through inductance 3. An axially symmetric magnetic lens 13 is installed inside the protrusion of the bottom half of the resonator to form an electron beam in the channel of the accelerator and extraction device 6. The extraction device is connected to the flange of the magnet lens through the vacuum valve and bellows unit. The single-stage RF generator is installed directly on the vacuum tank of the resonator and is connected to the resonator by means of coupling loop. The generator is designed using the circuit with a common grid. It works in the self-excitation mode with frequency close to the specific frequency of the resonator.

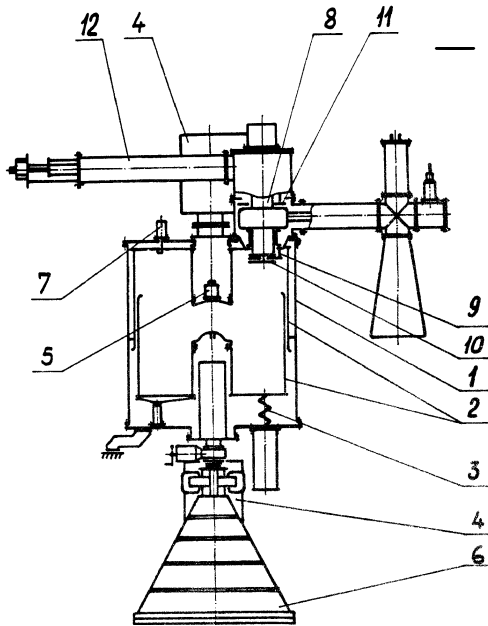

Figure 1: Main elements of ILU-6 electron accelerator: 1 – vacuum tank; 2 – RF cavity divided into 2 halves; 3 – input of constant bias voltage for lower cavity half; 4 – high vacuum pumps; 5 – electron injector; 6 – scanning horn; 7 – measuring loop; 8 – RF generator; 9 – coupling loop; 10 – coupling vacuum capacitor; 11 – feedback circuit, 12 – cathode circuit tuning line.

ACCELERATOR ILU-8

The ILU-8 machine is the result of ILU-6 further development. It is designed mainly for cables and tubes processing (Figure 2). This accelerator does not require construction of a special protected premise (hall) and can be placed in usual industrial shop. It can work inside the local biological shielding. The local shielding of the accelerator is a kind of a box made of steel plates. Inside the box is divided into two parts. The upper part is used to place accelerating system with HF resonator and fore-vacuum system. The beam extraction device, air pipes of ventilation system and technological equipment are placed in the lower part of the shielding. The back wall of the shielding has the channels (labyrinths) for input of cables, air and water pipes. The removable front wall

serves as a door of a protective box. The thickness of radiation shielding in side walls part is 330 mm and in top is 240 mm. Gross weight of shielding is 76 tons.

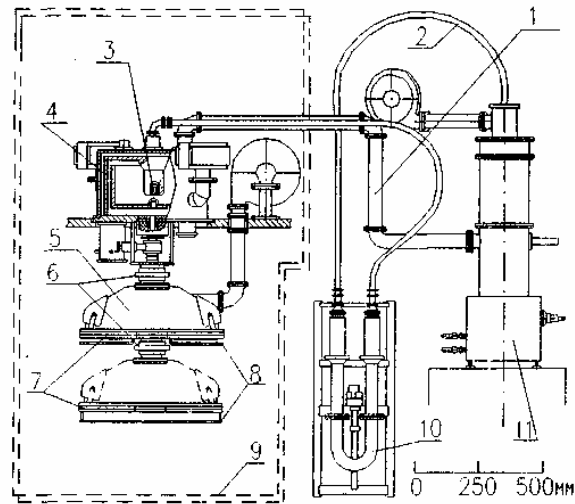

Figure 2: Main elements of ILU-8 electron accelerator: 1 – RF cavity power supply feeder; 2 – feedback RF system cable; 3 – cathode unit with control electrode; 4 – RF cavity of the accelerator; 5 – output device; 6 – deflecting magnets; 7 – output windows; 8 – beam collectors; 9 – contour covering elements placed into the individual radiation protection; 10 – phase shifter; 11 – RF generator.

ACCELERATOR ILU-10

The model ILU-10 is purposed mainly for processes requiring increased electron energy up to 5.0 MeV [1]. The dimensions of this machine are not sufficiently greater than the dimensions of ILU-6. For needs of processes requiring increased beam power the accelerator is supplied by two HF generators (Figure 3). Unlike ILU-6 machine, the resonator of ILU-10 machine is performed as a whole unit without separation on two halves as in ILU-6. As the result of the optimization work the resonator operates without discharges. Its shunt resistance is 9 Mohm, power, required for its excitation, is 1.4 MW, and the resulting beam pulse power is up to 2.5 MW. The main application area for ILU-10 is industrial sterilization by electrons and X-rays (optionally, by using special electron-X-ray converter). ILU-10 has two times more energy than ILU-6 so thickness of irradiation material is also increased more than twice.

On the ILU-10 we have an experience of sterilization of single-use medical products such surgical dresses and instruments (electron mode) and massive medical devices like dialyzers, catheters etc. (X-ray mode). Also ILU-10 is suitable accelerator for irradiate PE pipes with diameter up to 140 mm for hot water supply networks.

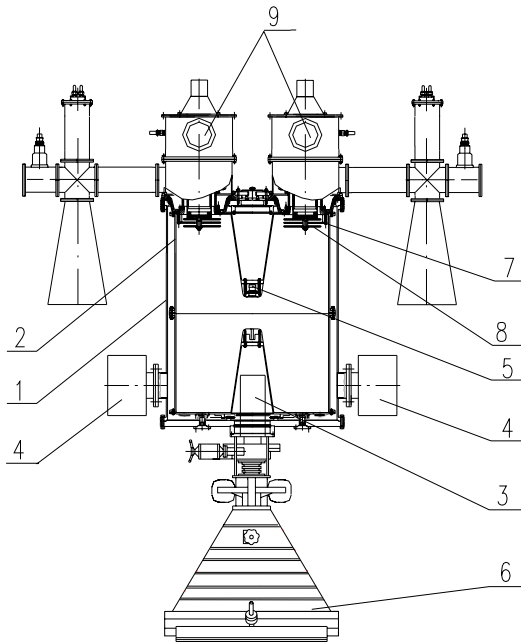

Figure 3: ILU-10 accelerator. 1 – vacuum tank, 2 – copper toroidal cavity, 3 – magnetic lens, 4 – ion pumps, 5 – grid-cathode unit, 6 – beam extraction device with linear scanning, 7—coupling loop support, 8 – vacuum capacitor, 9 – RF generators.

PROJECT OF ACCELERATOR ILU-12

New industrial accelerator with electron energy up to 5 MeV, and average beam power of up to 300 kW was designed basing on experience of work with the ILU accelerators [2]. The design of its accelerating system is shown in Figure 4. The accelerating structure consists of five modules and forms three complete accelerating cells, two accelerating half-cells and four coupling cells. The new machine is relatively simple in its production and adjustment. The electrons are accelerated in the low frequency multi-resonator standing wave structure with on-axis coupling resonators. This design makes it possible to decrease power losses in each resonator comparing with the single-resonator accelerator (at the same average beam power level) and to obtain the electron efficiency of the accelerator about 70%.

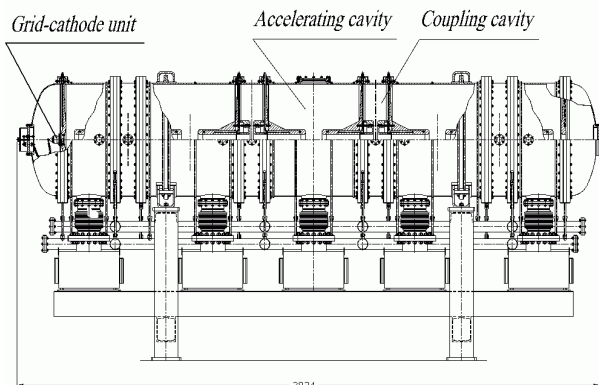

Figure 4: General view of accelerating structure.

ELECTRON BEAM EXTRACTION

The pulse nature of electron beam generated by ILU machines permits to design the beam extraction devices for radiation technologies forming the irradiation zones for multilateral irradiation of objects having the various forms. It enables one to increase beam usage efficiency and in some cases to reduce the electron energy required for irradiation, or to expand the nomenclature of treated products.

The electron beam extracted into the air through foil. Usually three types beam extraction device can be used: linear scanning device for treatment of flat and complex form products, 3-window extraction device and beam extraction device with X-ray converter.

In the linear scanning device each pulse of the beam is scanned along the length of extraction window. The control of the current of the scanning magnet and using additional magnet lenses to allow forming complex dose distribution along the foil. Some applications requires the dose bumps on the ends of extraction windows. It allows to irradiate only separate parts of the products.

In the 3-window extraction device beam pulses are scanned sequentially along its upper windows and along the left and right parts of lower window (Figure 5). This type of extraction system is using for 4-side tube or cable irradiation

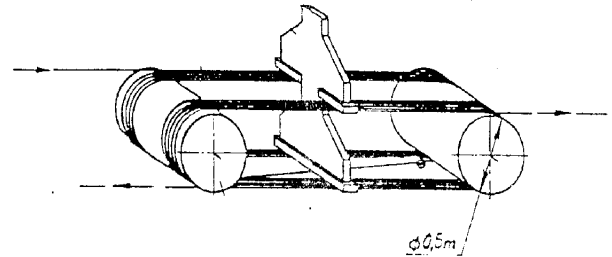

Figure 5: 4-side irradiation system.

To generate X-ray the electron beam can be directed to the X-ray converter. The technological process of the product treatment requires the certain type of the extraction device. For example, the beam bent at an angle of 90 grades enables a substantial simplification in the design of the vertical hanging conveyor system for subjecting the treated product to two-sided irradiation.

REFERENCES

- [1] V.L. Auslender et al., "Electron accelerator for energy up to 5.0 MeV and beam power up to 50 kW specially designed for use in industrial applications", IMRP 2006, Kuala-Lumpur, Feb 2006, p. 156.
- [2] V.L. Auslender et al., "Project of high power linear accelerator for E-beam and X-ray processing", IMRP 2006, Kuala-Lumpur, Feb 2006, p. 157