

BEAM POSITION MONITOR SYSTEM FOR PEP-II

Stephen R. Smith, G. Roberto Aiello, Linda J. Hendrickson, Ronald G. Johnson, Mark R. Mills, and Jeff J. Olsen, Stanford Linear Accelerator Center, Stanford, CA 94309, USA

Abstract

We describe the beam position monitor system built for PEP-II, the B-factory at SLAC. The system reports beam position for bunches of between 5×10^8 and 8×10^{10} electron charges, either singly or as continuous streams of bunches every 4.2 ns. Resolution at full charge is to be better than 10 microns in a single turn. Higher resolution is available via on-board multi-turn averaging. The position signal is processed in a 20 MHz bandwidth around 952 MHz. This bandwidth, rather broader than that typical of RF position monitors, allows good resolution for low charge single bunches. Additional novel features include stringent control of return losses in order to minimize cross-talk between nearby bunches which may contain very different charges. The digitizing electronics is multiplexed between the two PEP-II storage rings. Design, construction, and installation experience, as well as first results with beam are presented.

1 PEP-II

The PEP-II B-Factory¹ is based on colliding e⁺ and e⁻ beams stored in two rings operating at different energies. Currently the high energy ring is nearly complete; the low energy ring will be installed later this year. Both rings will contain up to 1658 bunches of electrons or positrons. The high energy ring will store currents up to 1 Amp, while the low energy ring, to be installed later this year, will operate to 3 Amps. The machine is to operate as a factory, meaning that the machine is expected to be colliding efficiently a large fraction of the time; sufficient diagnostics must be available to keep it running optimally.

Parameter	Value
Position Monitors	608 in two rings
RF frequency	476 MHz
Bunch spacing	238 MHz
Filled bunches	1658
Revolution Frequency	136 kHz
BPM Processors	170
Processing frequency	952 MHz
Time resolution	~ 5 bunches
Measurement rate	136 kHz
New measurement every	120 Hz

Table 1. PEP-II and beam position monitor system parameters.

Challenging aspects for the BPM system are the need for high dynamic range, from 8×10^{10} e⁺ per bunch at a 238

MHz rate, down to a single bunch of 5×10^8 e⁻. Good resolution and stability are required, as is the ability to measure even low-charge single bunches injected into an 80 ns gap in an otherwise filled storage ring.

Measurement Mode	Required Resolution (σ)
Single bunch, single turn	1 mm @ 5×10^8 e ⁻ and 100 μ m @ 1×10^{10} e ⁻
Single bunch, 10^3 turns	15 μ m @ 1×10^{10} e ⁻
Multi-bunch, single turn	< 10 μ m @ 1×10^{10} e ⁻

Table 2. BPM resolution requirements.

2 BEAM POSITION TRANSDUCERS

Each monitor consists of four buttons welded into the beam duct walls. Most BPM's have their button signals added pairwise so they read out either horizontal or vertical position. Buttons are 1.5 cm diameter in beam ducts with radii from 3.3 cm in the arc chambers to 4.5 cm in the straight sections. PEP-II RF is at 476 MHz. The first harmonic, 952 MHz was chosen for the BPM processing frequency. The button transfer impedance was calculated with MAFIA, as were wake-field impedances due to the buttons. The latter led to slight redesign of the buttons to meet the wake-field budget consistent with providing sufficient signal to meet BPM resolution requirements at low current.

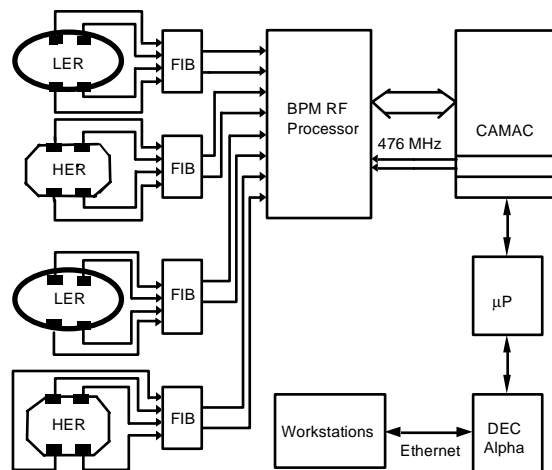

Figure 1. Diagram of BPM system, showing beam pickup pickups, filter-isolator boxes, BPM processor, CAMAC, and control system.

3 FRONT-END ELECTRONICS

Button signals are preprocessed in a “filter-isolator box” (FIB) mounted within a few feet of the buttons. This device is a constant input impedance 952 MHz band-pass filter with an RF isolator on each output so that its outputs are well-matched to the 50 Ω long-haul cables. Low S_{22} is needed to suppress round-trip reflections on the long-haul cable plant which would otherwise contaminate measurements of small single-bunches injected into a short gap in the high-current stored beam. The FIB sums the buttons pairwise for those BPM’s where only a single coordinate is measured. It also provides a DC block and HV bias capability should we decide to place an ion-clearing field at the button locations.

4 DIGITIZING ELECTRONICS

The choice of 952 MHz as the processing frequency constrains the digitizing electronics to be located in the tunnel. Signal loss and cable costs prohibit bringing the signals out of the tunnel except for the BPM’s closest to the centers of the straight sections. The processors are in CAMAC crates underneath the high energy ring bend magnets, which provide some shielding from synchrotron radiation.

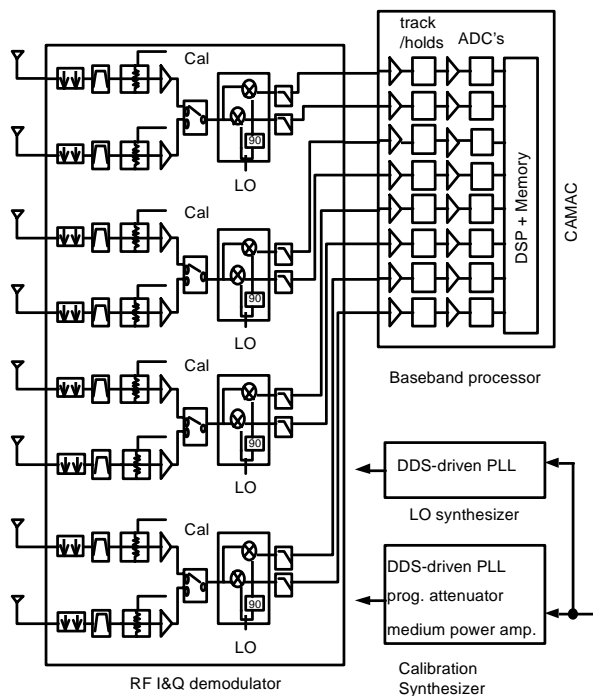

Figure 2. Ring I&Q BPM Processor block diagram. Each measures an X and Y BPM for each of two rings.

Signal processing is based on direct quadrature (I&Q) down-conversion of the 952 MHz bunch harmonic present in the button spectrum. A 20 MHz bandwidth was chosen to provide adequate signal-to-noise in the measurement

of low-charge single bunches. The ratio of bandwidth to center frequency swayed the decision toward direct down-conversion rather than the more conventional dual conversion via an intermediate frequency. Quadrature demodulation was chosen to eliminate the need for either a stable phase reference or a PLL locked to the beam which might prove troublesome at low currents absent stored beam.

Each processor module handles BPM’s from both storage rings, selectable by a programmable high-isolation switch. The processor signal path includes a calibration coupler, a band-pass filter, programmable attenuator, and low-noise preamplifier in front of the switch. The ring-selection switch is followed by a quadrature demodulator which downconverts the 952 MHz signal directly to baseband. Both the in-phase and quadrature components are low-pass-filtered, sampled, and digitized at the ring revolution frequency. A DSP converts eight digitized vector components to the four button amplitudes. Position is calculated from the ratios of the differences of the amplitudes divided by their sums. The DSP also computes multi-turn averages, if requested.

5 CALIBRATION SCHEME

Each measurement of an X,Y position requires accurate measurement of the I and Q components of the signals on four buttons. Thus there are 8 voltages measured. Assuming linear response of the system, this requires knowledge of 18 calibration parameters: 8 pedestals (or ADC zero offsets), 4 ratios of the gains of in-phase channels to their respective quadrature channels, 4 I-to-Q phase angle errors, and the two ratios A_{up}/A_{down} and A_{left}/A_{right} which give the position offsets of a centered beam. These calibration parameters can be expected to drift with time and temperature and, in a factory machine which can’t shut down to re-calibrate, must be measurable in the presence of stored beam.

Calibration tones, synthesised by an on-board DDS-driven PLL, are injected into the processor signal path upstream of the initial band-pass filter. Gain differences upstream of this point are expected to be static, and measured in the lab. The downconverted I & Q components are digitized at the ring-turn rate of 136 kHz and fitted to a sine wave at the difference frequency between the local oscillator and the calibration tone. Calibration data is acquired during the ion-clearing gap. Beam-induced signal is further rejected by the fitting process when the the L.O. and calibration frequencies are chosen to be different from each other and from the 952 MHz harmonic of the bunch frequency. The amplitude, offset, and phase angles of the fitted sine curves provide all the needed calibration data.

A train of bunches at 4.2 ns spacing produces a line spectrum at the button, while a single bunch passing the button gives a spectrum broad compared to the bandwidth of the electronics. For bunch-train measurements

the processor is calibrated at 952 MHz, while for single-bunch measurements gains are averaged over the channel bandwidth.

6 STATUS

Checkout of the processing electronics in the tunnel indicate the resolution and accuracy requirements are met. Measurements of simulated beam show 10^3 turn resolution $\sigma < 1 \mu\text{m}$ at moderate currents.

All high-energy ring BPM's are installed, except for those in the interaction region. First beam was injected into the high energy ring and transported to a temporary beam dump upstream of the interaction region on May 10.

The beam was seen on BPM's, but neither the beam nor the response of the position monitors to it are well-characterized at this time.

11 ACKNOWLEDGEMENTS

Work supported by the Department of Energy, contract DE-AC03-76SF00515.

REFERENCES

- [1] PEP-II, An Asymmetric B Factory, Conceptual Design Report, SLAC-418, June 1993.