

A PROPOSED NEW HOM MONITORING SYSTEM FOR THE SRS

P. A. McIntosh, CLRC Daresbury Laboratory, Warrington, WA4 4AD, UK.

Abstract

A programme of work has recently been completed on the SRS, whereby a longitudinal coupled bunch (LCB) instability which was being driven in one of the RF cavities[1], was eliminated at high currents by adjustment of the cavity water temperature[2]. The technique for identifying irregularities in the action of particularly the RF cavities, has now been well established at Daresbury, and certain aspects of the identification process and even necessary corrective measures can be automated. This paper outlines a proposed new diagnostic system on the SRS which identifies when a HOM is resonated within a cavity and provides compensation by automated adjustment of its operating temperature.

1 INTRODUCTION

Since the upgrade of the beam steering control system on the SRS to allow global servoing (GS) of the electron beam and local vertical servoing (LVS) of the photon beam down individual beam lines, the control of the circulating electron beam has been greatly improved. Measures that have been implemented include the installation of highly accurate electron beam position monitors (BPM) giving $1\mu\text{m}$ resolution, plus improved photon tungsten vane monitors (TVM) providing sub- μm resolution. The stringent requirements of maintaining the electron beam orbit, and consequently the photon beam position, to these tolerances impacts on all components of the storage ring.

The RF system plays an important role and should be efficient in its operation and not cause the beam to deviate beyond the limits of the servoing systems. Instabilities introduced from the RF system are common place in circulating storage rings, and generally require some intervention from auxiliary control systems to minimise their effect. This paper outlines a control system adopted for use on the SRS which detects possible RF instability interaction with the electron beam and predicts, by way of a compensating shift in cavity operating temperature, a mechanism to avoid these instabilities.

2 THE MONITORING SYSTEM

Other laboratories around the world, such as SRRC[3], ALS[4] and PEP II[5] use active feedback systems, which detect the deviation from the required orbit due to cavity HOM interaction, and compensate by applying corrective kicks to the circulating beam in both the transverse and longitudinal planes. The real estate requirements for such a system on the space limited storage ring of the SRS

makes this approach impractical. Hence the diagnostic and corrective systems must occupy a minimum of space when installed and if possible use existing diagnostic equipment.

The system that has been adopted uses existing stripline monitors to detect, from the beam spectrum, any contribution from the RF cavities; additional monitors on both the cavity and its associated waveguide system identify which cavity the instability originates from, and from precise knowledge of each cavity HOM spectrum, a magnitude of temperature variation can be calculated to shift the HOM in frequency away from coinciding beam resonances.

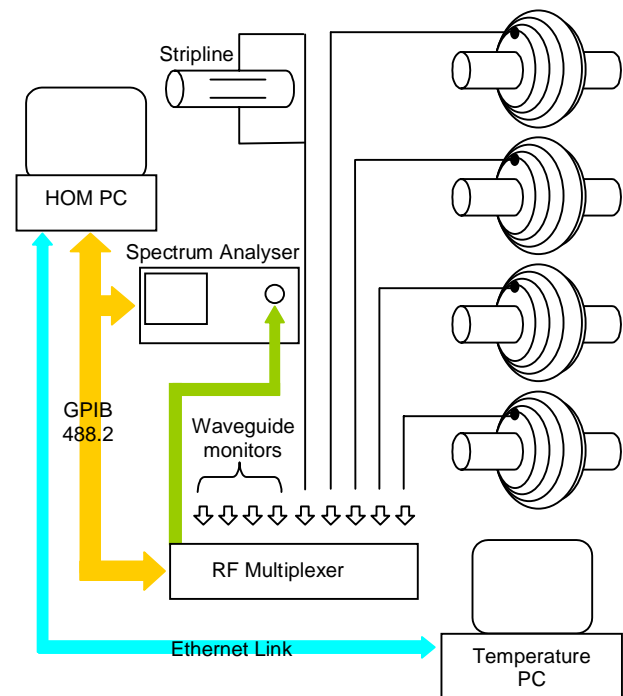

Figure 1. HOM Monitoring System layout

The monitoring system is controlled by an industrial PC via the data acquisition software LabVIEW. Through automatic control of the High Frequency Spectrum Analyser (HFSA), resonances about the beam orbit harmonics can be analysed.

2.1 Instability Identification.

For a uniform fill in the storage ring, ie. each circulating electron bunch containing approximately the same current, then the beam spectrum will only contain components n of Bf_{rev} , where B is the number of bunches and f_{rev} is the revolution frequency. Peaks at other frequencies indicate a non-uniform fill or that the beam

exhibits some coherent oscillation. Providing these oscillations cause the beam to move in a coherent way, the beam spectra will contain components:

$$f_{\mu,n}^{\pm} = nBf_{rev} \pm (\mu f_{rev} + f_{osc}) \quad \text{Eqtn. 1}$$

where:

- μ = integer corresponding to the CB mode number
- f_{osc} = product of the fractional tune by f_{rev}

The $f_{\mu,n}$ peaks are observed as side bands of the main frequency components nBf_{rev} . Modulation of the beam with a frequency $(\mu f_{rev} + f_{osc})$ gives rise to these side bands and this modulation component exists if the beam contains a coherent oscillation with frequency f_{osc} (or $f_{osc} + mf_{rev}$)[6]. For instability identification on the SRS, eqtn 1 holds true and can be used as the basis for an algorithm to detect spurious resonances from the electron beam itself. Knowing the synchrotron and betatron fractional tunes of the machine, evidence of the longitudinal CB (LCB) and transverse CB (TCB) instabilities can be located. Once a resonance has been detected, it is then necessary to determine whether the frequency is emanating from within the RF cavities.

2.2 HOM Determination

The HOM properties of each of the installed cavities are known and are extensively documented. More recent investigations have enabled the HOM's to be characterised in terms of both cavity temperature and tuner position[7]. The results of these characterisations have shown that for the strong monopole and dipole modes the variation in temperature has a linear effect, whereas changing tuner position introduces a more non-linear response in terms of the HOM frequency. The combined effect on HOM frequency can therefore be seen as a large non-linear frequency dependence on cavity tuner position, with a much smaller linear dependence on operating temperature.

The cavity monitor points are selective in their HOM identification. The cavity probe monitor is a magnetic probe which is sensitive to accelerating modes and will therefore only (to any certain degree) allow monopole HOM detection. The waveguide monitors chosen are E or H plane filter monitors which detect HOM resonances that exit the RF cavity via the coupling port. The restriction on the modes available to be detected at this point depends on the frequency of the HOM being sufficiently above the port cut-off to allow propagation.

The possible number of HOM's that can be excited in the SRS cavities are limited to 4 monopole, 6 dipole, 4 quadrupole and 2 sextupole. For the investigation for an automated monitoring and corrective control system, only algorithms for the monopole and dipole modes are to be included.

2.3 Correction Assessment

Having established that the observed instability is due to a HOM being resonated within one of the cavities, and having identified in which cavity the instability source is originating, some form of correction may then be implemented. The mechanism that has been chosen to move the HOM frequency spectrum to a region that is less susceptible to excitation from the beam is cavity temperature adjustment.

The SRS already has installed a diagnostic system which monitors all the critical power levels in the RF system of the storage ring, and in addition monitors both the temperature and water flow systems for the klystron and RF cavities[8]. The monitoring system also allows control of certain parameters including cavity temperature.

The assessment of required temperature change on a specific RF cavity to aid non-excitation of a HOM is complex. Not only does the adjustment of cavity temperature affect the mode under investigation, but also all other HOM's as well as the fundamental accelerating mode. By compensation using the cavity plunger tuner, the accelerating mode frequency can be maintained, whilst shifting the troublesome HOM away from any natural beam resonance and also not introducing any other HOM into a region of frequency space that could again allow HOM excitation.

3 PRELIMINARY RESULTS

The data acquisition software LabVIEW is used to compare the beam spectrum when beam instabilities are evident with that of a stable beam spectrum, in both the vertical and horizontal planes. This allows a localisation in frequency space as to where particular cavity instabilities appear when folded down to the base-band. Figure 2 shows the spectrum difference when a 1390MHz longitudinal HOM is excited.

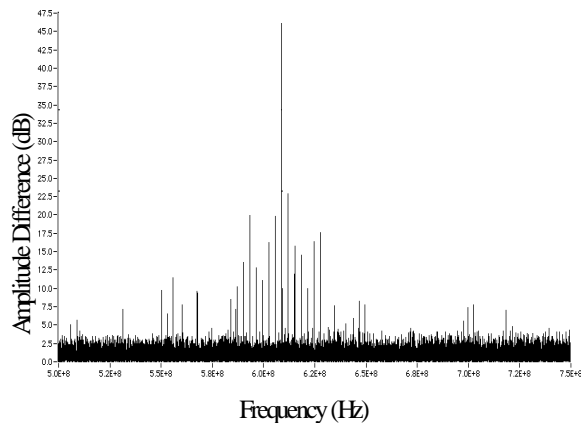

Figure 2. Instability Beam Spectrum Difference.

The maximum difference occurs at $-f_s$ from the 35th orbit harmonic, which when folded back into the natural frequency band, gives:

$$f_{125,n}^{\pm} = 2Bf_{rev} \pm (125f_{rev} + f_s) = 608.91 \text{ or } 1389.9\text{MHz}$$

The cavity probe monitor point provided a good diagnostic for this mode, showing a large response at 1389.9MHz. The signal amplitude was approximately 10dB larger for cavity 2 than any of the other cavity signals (see Figure 3).

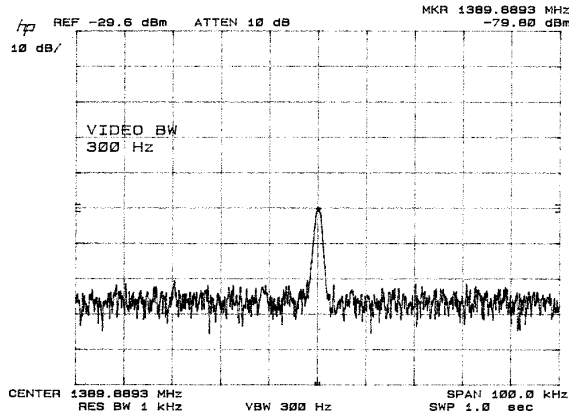

Figure 3. Cavity 2 Probe Signal.

Knowing the response of this mode to both cavity temperature and tuner position, a prediction for the change in cavity operating temperature could be made. An increase in cavity 2 temperature from 50°C to 52°C had the effect of shifting the mode frequency sufficiently away from any beam resonance, such that excitation of the 1390MHz mode could not occur at currents below 260mA.

4 FURTHER WORK

Although the HOM monitoring system is not yet fully completed, the instability identification process using the beam spectrum works well and allows accurate pinpointing of any instability in the orbiting electron beam, whether due to the RF system or not. Having detected an instability resonance, the process of identifying a cavity HOM as the probable cause has also been proved using the LabVIEW control software. The required correction by temperature adjustment is however not yet

implemented into the main control program, and correction thus far has been done manually. It is hoped that the 3 stages of instability identification, HOM determination and temperature compensation can be combined in the near future, to enable fully automated HOM monitoring.

The interface to the temperature control PC has not yet been implemented and should be relatively straightforward using the TCP/IP utilities within LabVIEW to allow the HOM monitoring PC to activate a control on the temperature control PC and therefore implement a change in cavity temperature.

5 CONCLUSIONS

The benefits of such a system for the SRS are great, particularly in terms of the SRS user requirements whereby they require strict control of the photon beam position. To date the diagnostic system has proved invaluable in determining where in frequency space to start looking for potential cavity HOM's. The ability of the system to then track an identified cavity instability and assess any changes as a function of cavity temperature and consequently cavity tuner position, has also proved very useful.

It is clear that there is still a lot of development work to be completed to allow the system to be fully integrated into the main SRS control system. The benefits of such a system would inevitably mean a more efficient RF system providing a stable electron beam orbit and consequently a more reliable photon beam for users.

REFERENCES

- [1] 'Cavity-Beam Instabilities on the SRS at Daresbury', P A McIntosh and D M Dykes, Proc. PAC, 1995, Dallas, pp3125-3127.
- [2] 'Higher Order Mode (HOM) Induced Longitudinal Coupled Bunch (LCB) Instabilities at the SRS', P A McIntosh and D M Dykes, Proc. EPAC 1996, Sitges, pp1135-1137.
- [3] 'Performance of the Transverse Coupled-Bunch feedback System in the SRRC', K T Hsu et al, SRRC, Taiwan, Proc. EPAC 1996, Sitges, pp1920-1922.
- [4] 'Longitudinal and Transverse feedback Kickers for the ALS', J N Corlett et al, Proc. EPAC 1994, London, pp1625-1627.
- [5] 'Bunch-by-Bunch Longitudinal Feedback System for PEP-II', G Oxoby et al, Proc. EPAC 1994, London, pp1616-1618.
- [6] 'Critical Test of Coupled-Bunch Instability Theory', H Kobayakawa et al, Jap. Journal of App. Phys., vol25 No6, June 1986, pp864-874.
- [7] 'Temperature Dependent HOM's in the SRS Cavities', P A McIntosh, Proc. EPAC 1996, Sitges, pp1961-1963.
- [8] 'Implementation of a New RF Monitoring System for the SRS Using LabVIEW', M J Pugh and A R MacDonald, these Proceedings.