

# THE NEW POSITIVE ION INJECTOR PIAVE AT LNL

A. Lombardi, G. Bassato, A. Battistella, M. Bellato, G. Bezzon, L. Bertazzo, G. Bisoffi, E. Bissiato, S. Canella, M. Cavenago, F. Cervellera, F. Chiurlotto, M. Comunian, A. Facco, P. Favaron, G. Fortuna, S. Gambalunga, M. Lollo, M.F. Moisis, V. Palmieri, R. Pengo, A. Pisent, M. Poggi, A.M. Porcellato, F. Scarpa, L. Ziomi  
INFN-LNL, via Romea 4, I35020 Legnaro (PD), ITALY  
I. Kulik, ILTPE Kharkuv, Russia; A. Kolomiets, S. Yaramishev, ITEP, Moscow, RUSSIA  
H. Dewa, Institute for Chemical Research, University of Kyoto, JAPAN

## Abstract

The construction of a positive ion injector for the linac ALPI, named PIAVE, at Laboratori Nazionali di Legnaro was funded in 1996. The beam parameters of the injector, consisting of two Superconducting Radio Frequency Quadrupoles (SRFQ) and eight superconducting Quarter Wave Resonators (QWR) for an equivalent voltage of about 8 MV ( $U^{28+}$  beam), are fixed. The building is ready, infrastructures and beam transport lines are being ordered. The superconducting RFQ's are in the prototyping phase. The general status of the project is reported in this paper, including cryostat and cryogenics, bunching systems, diagnostic devices and electronic control systems.

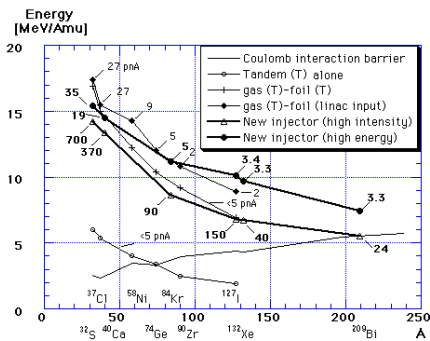

Figure: 1 Performances of the Legnaro accelerator complex including the foreseen upgrading given by PIAVE.

## 1 SCOPE OF PIAVE

Presently the Legnaro accelerator complex consists in a XTU tandem followed by the superconducting linear booster ALPI. It delivers ion beams to the experimental rooms with beam intensities on the target of few particle-nA, masses ranging from protons to masses of the order of 100 amu ( $^{81}\text{Br}$ ) and energies well above the Coulomb barrier as it is shown in figure 1 [1]. The main constraint for the existing facility is the presence of the stripping section inside the tandem that limits the performance of the accelerator complex towards the heavier masses, up to 200 amu, and the beam intensities. On the other hand the nuclear physicists are interested to the very heavy ion beams with energies around the interaction barrier.

As a consequence of this request a new injector for the ALPI booster has been proposed at the beginning of 1996. The injector PIAVE ( Positive Ion Accelerator for Very-low Energy ) is meant for increasing the mass range of the facility up to lead ion. PIAVE will use the beams generated by the ECR Ion Source Alice placed on a high voltage platform operated at 350 kV [2].

Figure 1 describes the performance of the tandem-ALPI complex and compares it with the foreseen capability of PIAVE in terms of specific energy of the beam versus the mass number. The values indicated near the curves are the beam currents on the target, in particle-nA, including a realistic transmission coefficient in ALPI of 50%. It clearly shows the possibility of reaching the heaviest masses keeping the energy of the beam above the Coulomb barrier and with beam currents on target more than adequate for nuclear physics experiments.

The project has a three years time schedule and a cost of about 8 Billion Italian Liras.

## 2 THE ACCELERATOR

PIAVE is a superconducting linac operating at a rf frequency of 80 MHz and containing two SRFQ resonators followed by eight QWR's. It accelerates beams from  $\beta=0.0089$  to  $\beta=0.045$ , in the case of a  $^{28}\text{U}^{238}$  beam, for an efficient injection into ALPI. The cavities are located inside three cryostats: one containing the two SRFQ and two, similar to the ALPI ones, containing four QWR's each.

The accelerator is connected to the ECR source, placed on the high voltage platform, on one side and to ALPI on the other side by matching lines containing the bunching systems to perform the longitudinal matching of the beam. The beam dynamics analysis of the whole system is completed [3] and the various component of the matching lines are in different phases of construction.

Figure 2 shows the layout of the machine, including the ECR high voltage platform.

The high voltage platform housing the ECR source is placed on a concrete base and its output beam line and accelerating column is displaced, both vertically and horizontally, with respect of PIAVE. The resulting transport line deflects the beam of  $180^\circ$  guiding it on a line some 5 meters below and some 2 meters to the left

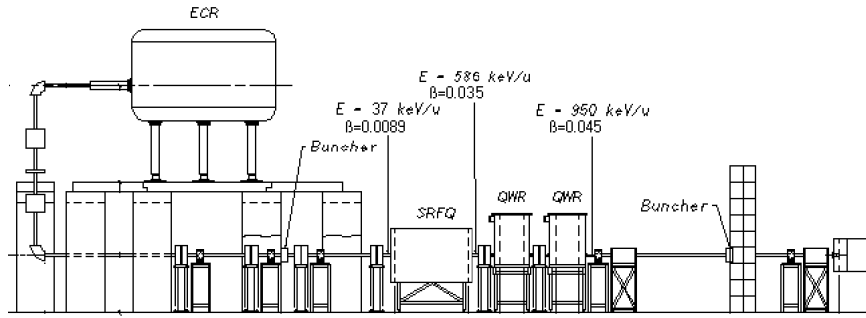

Figure: 2 The Layout of PIAVE

of the ECR output one, following the beam direction. All the magnetic elements of the line were ordered.

The beam analysis is performed by a magnetic spectrometer on the high voltage platform. Therefore the magnetic elements of the line are meant only for the transverse matching of the beam into the SRFQ's and to create the required beam waist at the buncher location.

The beam dynamics studies [3] determined the need for a very efficient bunching system with a low transverse emittance increase. The result of that is a quite innovative design of a triple harmonic buncher [4] realized with two independent cavities as it is shown in figure 3. The two cavities operate at 40-120 MHz and 80 MHz respectively.

The buncher, combining the absence of grids and the use of three harmonics, has a bunching efficiency of  $\approx 68\%$  and it requires a rf power of less than 100 W which allows the use of a room temperature system without severe cooling problems. The cavities are powered by three independent solid state amplifiers controlled by standard ALPI rf controllers. The operation of the first cavity at 40 and 120 MHz is possible due to the different field distribution of the two modes with a careful displacement of the tuners, the couplers and the pick-ups.

In the beam velocity range  $0.009 \leq \beta \leq 0.035$  the acceleration is performed by two SRFQ resonators operating at 80 MHz and made of niobium sheets electron-beam welded [5]. The accelerating structure of  $\sim 2.5$  meters long is split into two different resonators housed in the same cryostat. This choice is dictated by the limitation in the maximum storable energy inside a cavity compatible with the rf phase locking [6].

The novelty of the project, with respect of similar facility already operating in other laboratories, is the presence of the superconducting RFQ [7]. The beam dynamics specifications, the bunching of the beam, which is made before the RFQ with a triple frequency buncher described above, and the particular care put in the design of the cavity both for rf and vibration control reasons are the main peculiarities of the SRFQ design. The complete design of the SRFQ resonators is almost finished and the first stainless steel prototype is in its final construction stage [8].

The accelerating structure is changed, passing from the SRFQ to the QWR, following the indications of the beam dynamics studies at an energy of 578 keV/u, that

means  $\beta=0.035$  for the nominal uranium beam mentioned above. This beam velocity is too low for the injection into ALPI low  $\beta$  resonators. Therefore a section containing eight QWR's with an optimum  $\beta$  of 0.047 is foreseen for PIAVE. These cavities are similar to the ALPI ones and the first example is now under construction following the production procedures fixed for the ALPI resonators [9].

The matching line between PIAVE and ALPI contains two quadrupole triplets, an achromatic  $90^\circ$ , made of two bending magnets with a quadrupole singlet using the standard ALPI 'L-Bends', as well as two room temperature bunchers [3].

### 3 DIAGNOSTICS

To operate the machine eight diagnostic boxes are foreseen in the two beam transport lines. The boxes are equipped with the Beam Profile Monitors and longitudinal phase space diagnostics. Current monitors for the transmission control are located in several boxes. The main issue for this BPM's is the beam intensities expected from the ECR. We would like to use as much as possible our experience with ALPI where the BPM's are harps made of wires  $20 \mu\text{m}$  thick [10]. These BPM's have severe problems with the beam intensities and beam power foreseen for PIAVE, as it has been already experienced with the tandem beams before the charge analysis. The possible solution is to use strips instead of wires for the harps. Alternative solutions, such as residual gas detectors and rotating wires, will be considered.

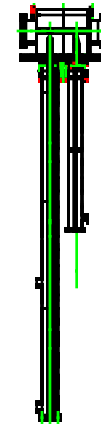

Figure: 3 Schematic of the PIAVE triple harmonic buncher

A transverse emittance measuring box is under construction for the commissioning of the low energy beam transport line and, afterwards, of the SRFQ and QWR's accelerator sections. The apparatus is able to measure beam spots of 60 mm and maximum divergence of 240 mrad with an angular resolution of 3 mrad. The emittance measurements box when it is placed at the output of the SRFQ section and moreover after the QWR section requires a dissipation of thermal power of the order of hundreds Watts.

#### 4 RF AND CONTROL

The resonator controller is an evolution of the ALPI QWR's controller. It operates in self-excited loop mode and locks the cavity phase by adding to the signal driving the amplifier with a reactive component in response to a phase error detection [11,12]. Improvements have been brought to the electronic board to reduce the phase-amplitude cross-talk and to make more accurate the search of the resonance peak. In order to broaden the SRFQ bandwidth to a range of  $\pm 10$  Hz, a solid state power amplifier delivering 1 kW CW in class AB will be used.

The new injector control system is an extension of the ALPI system and it is based on VME crates connected via Ethernet to UNIX workstation (DEC Alpha) for the operator interface. Some changes have been made to increase the performance; in particular the old CPU boards (68030) have been substituted by new ones equipped with the PowerPC processor running at 200 MHz clock. These boards provide a full support for the Fast Ethernet (100 Mbit/s) and this can be an option for a further system upgrade. The VME CPU boards operate under the real time OS Tornado (by Wind River Inc.).

#### 5 STATUS OF THE PROJECT

The project, which started officially in July 1996, is now in its construction stage for many components.

The ECR source is placed in its final position onto the high voltage platform and has been tested successfully with noble gas beams in May 1996. The resolution of the ion analysis proved to be satisfactory enabling to distinguish  $^{132}\text{Xe}$  from  $^{134}\text{Xe}$  and to detect a 10 V ripple in the ion source voltage. The high voltage power supply is ready to be installed and tested to the nominal voltage of 350 kV. The electrical power needed by the ECR equipment is provided onto the platform via an insulating transformer with a total power of 135 kVA at 380 V which has been already ordered. For general use with metals, a rf induction oven was built and an oven was tested up to  $1950 \pm 100$  °C. The beam after the accelerating column is foreseen for the beginning of 1998.

The magnetic elements of the transport lines have been already ordered and are expected to be delivered by the end of 1997. By that time all the ancillary systems, such as vacuum and diagnostics, will be ready for mounting.

The SRFQ2 stainless steel prototype is in its assembly stage and is expected to be finished by the middle of 1997. The niobium pieces for the resonator has been acquired.

The triple harmonic buncher has been designed and it will be ready for testing by the end of may 1997.

The test cryostat for the SRFQ resonators, with the internal screens and reservoirs made in titanium, is under construction. The cryogenic plant for PIAVE has to deliver 130 W at 4.5 K and 600 W at 80 K. The cooling power at 80 K will be provided by liquid nitrogen. A new refrigerating system for the liquid helium has been considered to avoid the overloading of the ALPI system.

In the framework of the PIAVE project a scaled model of a SRFQ working at 160 MHz in dummy cavity has been made for the first attempt of magneto-sputtering deposition of thin films. The preliminary results are encouraging both concerning the uniformity of deposition and the stability of the plasma.

#### REFERENCES

- [1] 'Status of ALPI and Related Developments of Superconducting Structures', by G. Fortuna et al, Proceedings of the XVIII International Linear Acc. Conf., Geneva 1996
- [2] 'Commissioning of the ECR source Alice', by M. Cavenago and G. Bisoffi, NIM A328(1993) p.262-265, and 'Selection of charge from the ECR Alice without forming a Waist', by M. Cavenago, NIM, A328(1993),266-269
- [3] 'Complete simulation of the heavy ion linac PIAVE', by A. Pisent and M. Comunian, these proceedings
- [4] 'The triple harmonic buncher for the PIAVE project', by A. Facco and F. Scarpa, to be published in the LNL Annual Report 1996.
- [5] 'Superconducting RFQ cavities of the new heavy ion injector at Legnaro', by G. Bisoffi et al., Proceedings of the "Seventh Workshop on RF Superconductivity", Paris, October 1995.
- [6] 'Status of the Superconducting RFQ project for the Legnaro New Positive Ion Injector', by A. Pisent et al., Proceedings of EPAC 1996, Sitges (Barcelona).
- [7] 'Design of a Superconducting RFQ resonator', by I. Ben-Zvi et al, Particle accelerators 35 (1991) 177
- [8] 'Prototype of a Superconducting RFQ for Heavy Ion Injector Linac', by G. Bisoffi et al., these Proceedings.
- [9] 'Experience with the bulk niobium low  $\beta$  resonators at LNL', by A. Facco et al., Proceedings of the 7th International Conference on Heavy Ion Acceleration Technology, Canberra, Nucl. Instr. and Meth. in Phys. Res. A 382 (1996) 107-111
- [10] 'The beam diagnostic system of ALPI Post-Accelerator', by M. Bellato et al., Proc. of the 3rd EPAC 1992 Berlin.
- [11] 'The control and electronics of a superconducting booster module', by I. Ben-Zvi et al., Nucl. Instr. and Meth. A245 (1986)1.
- [12] 'Status of the ALPI control System', by G. Bassato et al., Proc. IEEE 7th Conf. on Real Time 91 (1991) 285; 'The Control System of the L.N.L. LINAC', by G. Bassato et al, Proc. of the 3rd EPAC, Berlin 1992.