

PLS RF System Operation during the Commissioning

M. Kwon, I. H. Yu, H. J. Park, D. H. Han, M. Yoon, Y. S. Kim
Pohang Accelerator Laboratory, POSTECH
Pohang, Kyungbuk 790-768 KOREA

Abstract

The storage ring of the Pohang Light Source(PLS) is designed to store 100s mA of 2 GeV electrons injected from the full energy linear accelerator. To compensate for the synchrotron radiation loss three RF cavities were installed in one of the straight sections powered by three 60 kW-TV transmitters independently. Phase and amplitude are controlled by the separate low level systems. During the commissioning, since the beam lifetime is limited by the vacuum pressure, various accelerating voltages were set to investigate the system characteristics. Even one cavity is enough to store 100 mA of beam, whereas the vacuum-limited lifetime is few minutes at 1 mTorr. The cavity HOM-induced multi-bunch instabilities were observed at certain condition and cured to some extent by shifting phase and water temperature.

General description of RF system performance and trouble-shoots during the commissioning are presented.

1.INTRODUCTION

The RF system of the storage ring of the PLS has three cavities to store few hundreds mA of 2 GeV electron beam, which

are powered by three klystron amplifiers. During the first phase of the commissioning one or two cavities were mostly used storing up to 200 mA with 800 kV of the total gap voltage. In the final week of the commissioning three cavities were powered with 1200 kV of the total gap voltage storing 300 mA of electron beam[1]. Since 1992, a prototype RF system has been installed and tested in the high power RF test facility . The cavity was manufactured by Toshiba following the design of the upgraded Photon Factory's. A set of RF station includes the Daresbury-made low level system. Low and high power tests of the cavity, circulator and klystron amplifier were performed with this prototype low level system. After testing a prototype RF system, a few modifications and enhancements were made for the storage ring RF system. A schematic layout of a station of the PLS RF system is shown in Fig. 1.

From early 1994, RF system began to be installed in the storage ring tunnel posting cavities and vacuum chambers. Baking and conditioning were performed after installation in August 1994 and the commissioning of the storage ring began in September. Total RF power of 180 kW can provide enough power to store 300 mA at 1.2 MV of accelerating voltage. By the end of 1995 one more station will be installed and the total RF power will increase to 240 kW, which will store 200 mA of electron beam for the planned 2.5 GeV ramping experiment.

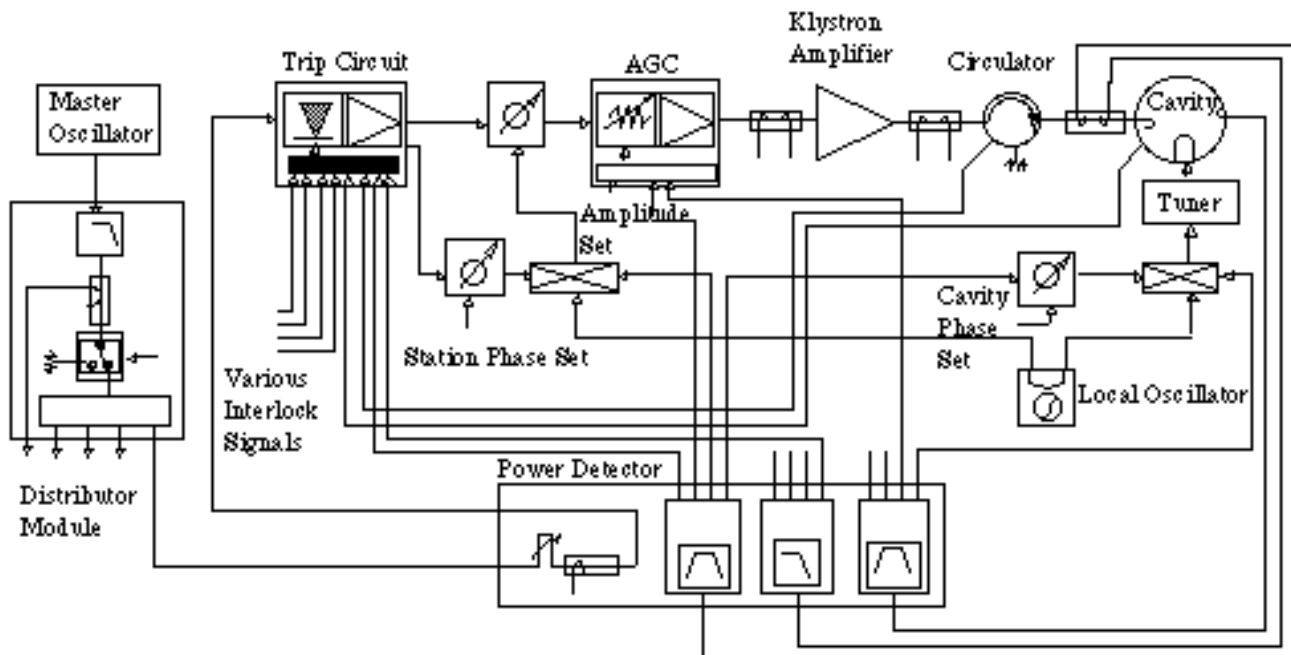

Fig. 1. A schematic diagram of the PLS storage ring RF system

Table 1 shows the present status of the PLS RF system installation.

Table 1. Current status of the PLS RF system

Klystron Amp.	Three cw-60 kW
Transmission Line	6 1/8" coaxial line
Number of Cavity	Three
Shunt Impedance	>8 MW
Unloaded Q	>35,000
Coupling Coeff.	1.8
Accelerating Volt.	400 kV/cavity

2. PLS RF SYSTEM ARRANGEMENTS

A RF station consists of one klystron amplifier, a circulator, a coaxial switch and a cavity connected by 6 1/8" coaxial transmission line.

The klystron amplifier is the 60 kW continuous wave(cw) TV transmitter manufactured by HARRIS. The driver input signal is set to 13 dBm maximum and the total gain is over 70 dB. The nominal beam voltage is 24 kV and the collect current is 5.8 A. For safety reason some important interlock loops are connected to the high voltage switch directly to shut it down as an emergency occurs.

The high power circulator was purchased with coaxial ports. The temperature control unit is provided for the good RF performance since the ferrite saturation magnetization is temperature dependent. The circulator provides a good isolation of the reflected power from the cavity to the klystron amplifier. The coaxial switch was installed after circulator to achieve a flexible operation and perform an independent test of the power system by simply selecting switch between the cavity and the water load.

The total length of the transmission line from the klystron amplifier to the cavity is less than 15 meter and the attenuation should be less than 0.5 dB. The measured attenuation is 0.13 dB.

The nose-cone type single cell cavities are installed and show good electrical and mechanical performance up to 70 kW of cw power. The cylindrical-shape ceramic window is used for the input coupler, which has a transition from WR-1500 waveguide to the coaxial structure. A disk-type window is currently being developed. The cavity HOM(higher order modes) suppressor is just a dummy block of which length can shift the dangerous frequencies if it is determined properly.

The impedance measurement stand was set up to assess the beam effect of the various vacuum components. The longitudinal impedance budget of the PLS storage ring is 2 Ω and the measurements were carried out in the frequency domain using the synthetic pulse technique[2]. The analysis of the measured data is underway and the total impedance seems to be within the budget. The ring impedance measurement is planned to be performed near future.

The low level system was improved from the Daresbury-designed prototype: change the local oscillator to the PLL synthesizer for flexible variation of the IF frequencies, use

constant impedance hybrid-type phase shifter for precise phase control with linearizer, and more redundant safety interlock control circuit, etc. The development of the precision oscillator and fast feedback loop are undertaken.

The VME system was adopted for the data acquisition and hardware control for the PLS storage ring. The UNIX-based control software which has the graphical user interface has been developed. All the RF components can be controlled and the system operation can be monitored remotely from the main control room.

The high power system and the cavities were cooled by the 25 degrees in Celcius low-conductivity-water(LCW). The cavity cooling temperature is regulated within 0.1 degree and able to be varied in 5 degree range independently. This is useful to shift the HOM frequencies

3. OPERATIONAL CHARACTERISTICS

In the beginning of the storage ring commissioning, single RF station was operated to make the problems usually confronted in the early phase simple. As the stored current increased, one more station was added. At the final week in 1994, three stations were fully operated to store 300 mA with 1.2 MV of the accelerating voltage.

Figure 2 shows the accelerating voltage and cavity input power of a cavity as a function of the amount of the stored current. Since the beam loading compensation was being worked, the accelerating voltage was kept constant as the input RF power increased gradually. For 400 kV of the accelerating voltage per cavity, 20 kW is required for cavity dissipation and 22 kW more is required for beam loading per each 100 mA increment of the stored current. Therefore for 400 kV of the accelerating voltage per cavity, three cavities can hold 500 mA of electron bunches.

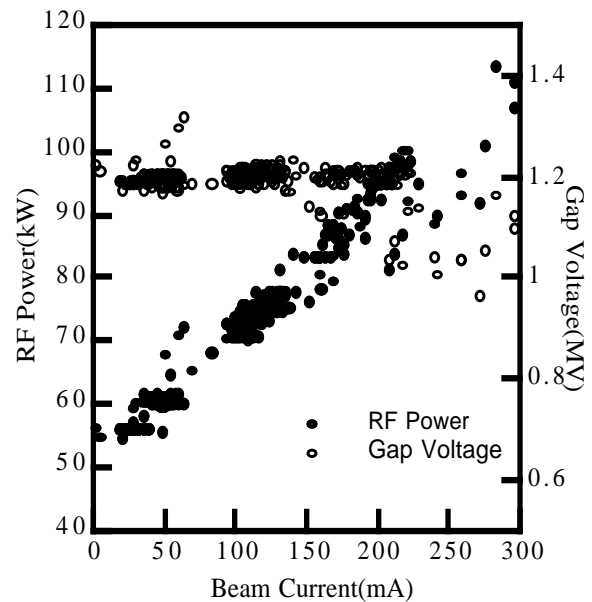

Figure 2. Beam current determines the gap voltage and the input RF power (Beam Loading Compensation).

Figure 3 shows the available operating regime with given RF power as the accelerating voltage and the beam energy change. RF acceptance is normally calculated as a function of the RF voltage. The calculation showed that 2.0% of the bucket height and 100 hrs of the Touscheck lifetime would be achievable with 1.2 MV of the accelerating voltage. Since the lifetime at present state is governed by the vacuum pressure, more photon conditioning is required to take advantage of the higher accelerating voltage.

The signal for the low level feedback loop was picked up from the cavity input port. In this way the beam effect on the control loop could be minimized. However, the beam loading compensation should be done in other way. A pickup signal from the cavity monitor port is used as the reference signal for regulating the accelerating voltage assuming that the same accelerating voltage always couples same amount of signal amplitude to the monitor probe. Since processing of data for this method is little slow, for fast injection it's hard to follow the beam current increments for beam loading compensation. Another method will be tested, in which the DCCT current signal becomes the reference and the required RF power for the beam loading is calculated and set it directly through the automatic gain control(AGC) loop in the low level system.

The phase and amplitude of the cavity input power were controlled within 0.1 degree and 0.5% of variation, respectively.

Phase between stations were adjusted by balancing the input power to all operating stations to share the same portion of the total beam loading.

The RF straight section where cavities were installed has four sputtered ion pumps (800 l/min total) and one roughing system. Four flexband bellows and two transitions and gate valves make the whole system assembly easy. The vacuum pressure after baking and conditioning is about sub-nanoTorr without beams. As the stored current increases, the pressure increases, too. However, since the dissipated power to the cavity is kept constant though RF power input to the cavity increases, the

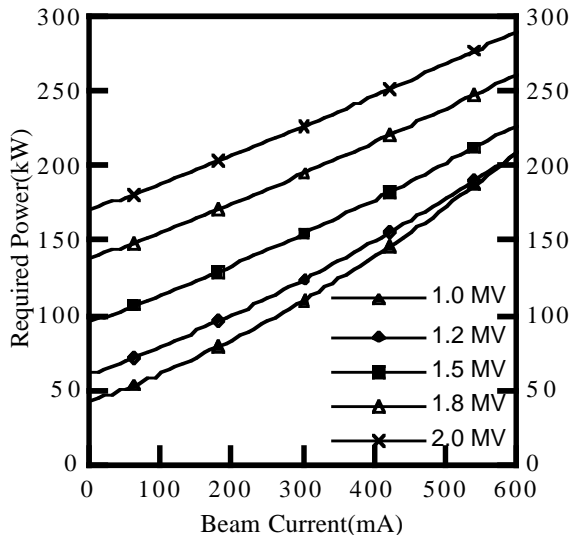

Figure 3. Operating window determined by the beam current, RF power and the accelerating voltage.

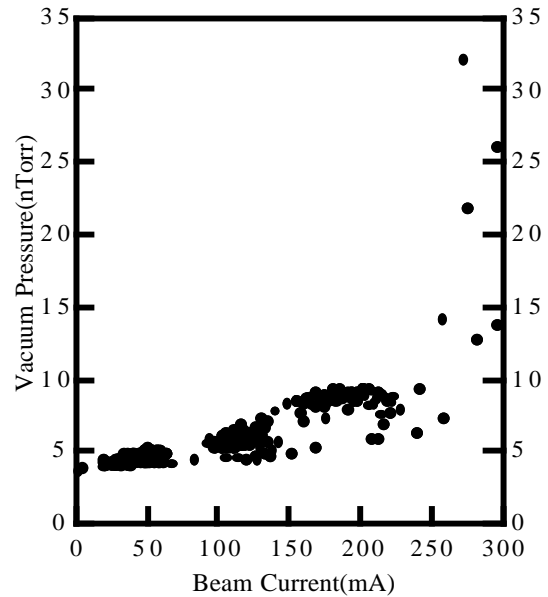

Figure 4. Pressure change due to the photon-induced-desorption(PID).

increment of the vacuum pressure comes mainly from the photon induced desorption. Figure 4 shows the pressure change during the variation of the stored current. Some vacuum burst followed by high reflection occasionally occurred as the stored beam went on instabilities.

The multi-bunch instabilities occurred non-systematically during the beam storage, causing to limit the upper bound of the total stored current and/or beam loss. Simply changing cavity resonant frequency little by changing tuning angle allows us to identify which cavity are causing instabilities. Changing the temperature of the cooling water cures instabilities to some extent in most cases.

4.FUTURE PLAN

One more station will be added by the end of 1995. Total RF power becomes 240 kW which allows operations with higher RF voltage, meaning larger acceptances and longer lifetime.

A systematic study on the multibunch instabilities will be performed. Method like the RF knockout is considered to identify the seed frequencies causing instabilities.

Thorough measurements of the chamber impedances and ring impedance are underway. The analysis of the measured data will be presented elsewhere. Some calculations using computer codes will be done to clarify the obscurity of the measurements.

The low level and control system will be improved and upgraded for more stable and reliable operation in preparation of the normal operation phase for the synchrotron radiation users.

REFERENCES

- 1.M. Yoon, in this conference.
- 2.F. Caspers, "Beam impedance measurement by wire method using a synthetic pulse techniques," IEEE NS-32 (1985) 1914.