

# PEP II STATUS AND PLANS\*

John T. Seeman<sup>+</sup>

Stanford Linear Accelerator Center, Stanford University, Stanford, CA 94309 USA

The PEP II B-Factory<sup>1</sup> project is an  $e^+e^-$  colliding beam storage ring complex to be built on the SLAC site. PEP II is designed to provide a luminosity of  $3 \times 10^{33} \text{ cm}^{-2}\text{s}^{-1}$  at a center of mass of 10.6 GeV with unequal energy beams of 3.1 and 9.0 GeV. The goal is to study CP violation in the B meson system. The project is being built by a collaboration of the Stanford Linear Accelerator Center, Lawrence Berkeley Laboratory, and Lawrence Livermore National Laboratory. DOE construction authorization was given in 1994. The asymmetric beam energies require two storage rings with the low energy ring (LER) supported above the high energy ring (HER). There will be one interaction point with head-on collisions, requiring magnetic separation of the beams, low values of the beta functions, and magnetic elements inside the solenoid of the BABAR<sup>2</sup> physics detector. The high luminosity necessitates a large number of bunches requiring advances in the vacuum design, damped RF cavities, and bunch-by-bunch feedback systems. The injection scheme uses the high current, low emittance, on-energy beams available from the SLAC linac. At present, the old PEP tunnel has been cleared and installation of the high energy ring has started. Several of the many papers on PEP II at this conference are listed in References 3-23.

## I. PARAMETERS

The general PEP II layout is shown in Figure 1 where the two rings are located in the former PEP tunnel. Two injection beam lines are built along the SLAC linac tunnel where the 3.1 and 9.0 GeV beams are extracted, transported, and injected into their respective PEP II rings. The LER magnets and supports are mounted above the HER dipole for ease of installation and maintenance, as shown in Figure 2. The general parameters of PEP II are listed in Table 1.

\* Work supported by US Department of Energy contracts DE-AC03-76SF00515, DE-ACO3-76SF00098, and W-7405-Eng-48.

<sup>+</sup> Representing the PEP II Staff from SLAC, LBL, and LLNL.

Table 1 Parameters of the PEP II B Factory

Parameter	Units	HER	LER
Circumference	m	2199.32	2199.32
Energy	GeV	9.0	3.1
Luminosity	$10^{33} \text{ cm}^{-2}\text{s}^{-1}$	3	3
Bunch spacing	nsec	4.2	4.2
Crossing angle	mrad	0	0
Energy spread	$10^{-4}$	0.61	0.77
Bunch length	cm	1.1	1.0
$\sigma_x$	$\mu\text{m}$	155	155
$\sigma_y$	$\mu\text{m}$	6.2	6.2
$\beta_x^*$	cm	50	37.5
$\beta_y^*$	cm	2.0	1.5
Tune shift $\xi_{x,y}$		0.03	0.03
x tune		24.57	36.57
y tune		23.64	34.64
$\tau_{\text{beam}}$	hours	4.2	5.3
$\epsilon_x$	nm-rad	48.	64.
$\epsilon_y$	nm-rad	1.9	2.6
Nb	$10^{10}$	2.7	5.9
Bunches		1658	1658
Bunch gap	%	5	2
Current	A	0.99	2.14
RF frequency	MHz	476	476
RF Cavities		20	6
Klystrons		5	3
RF voltage	MV	14.	5.5
Loss Per Turn	MeV	3.57	0.77
$\tau_{x,y}$	turns	5400	7200
$\nu_s$		0.045	0.035
# dipoles		192	192
# quadrupoles		290	326
Filling time	min	3	3
Injection rate	Hz	60	60
Injected bunch Q	$10^9$	1-30	1-30
Number of IRs		1	1
BABAR offset	m	0.37	-0.37
Solenoid field	T	1.5	1.5

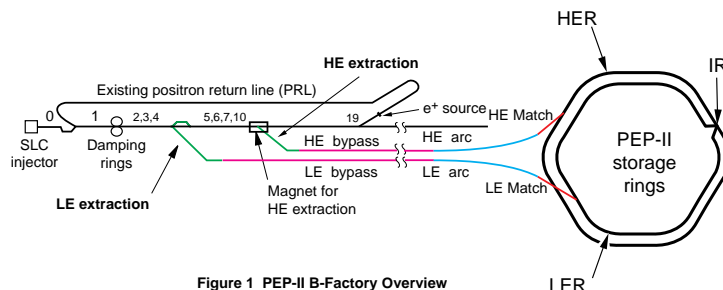

Figure 1 PEP-II B-Factory Overview

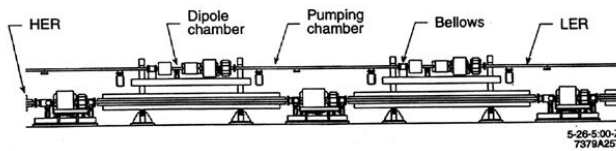

Figure 2 Cell layout

## II. HIGH ENERGY RING

The HER has an energy range of 7 to 12 GeV and is designed to store up to 3 A of electrons. The arc dipole magnets and sextupoles are refurbished from the original PEP. The quadrupoles are either refurbished (about half) or reworked magnets from PEP. The old 1 m long laminated quadrupoles are being cut in half which become PEP-II magnets with new end packs and coils. The refurbishing is nearly complete and the magnetic quality is still good. The HER magnets and supports are starting to be reinstalled in the tunnel as shown in Figure 3.

The HER vacuum system has octagonal copper extrusions in the arcs and cooled circular stainless steel pipes in the straights. The chamber cross sections are shown in Figure 4. The copper provides low outgassing and contains the x-ray radiation inside the chambers. The extrusions have started to arrive at SLAC with the e-beam welder to start work in July. A prototype copper chamber has produced the vacuum pressures required (a few nTorr).

The beam position monitor is shown in Figure 4b. MAFIA and measurements have been used to design the button to minimize the narrow band impedance which minimizes the coupled bunch instability. The signal processors are multiplexed between the two rings and operates at 952 MHz. Special electronics are needed to minimize the effects of cross coupling of the bunch signals and to handle up to 50 W of signal power potentially exiting a single button from a 1 cm offset beam. Each monitor can store 1024 single measurements.

The HER lattice has a phase advance of 60 degrees per cell with semi-local chromatic corrections near the IR including a beta bump scheme to reduce the sextupole strengths.



Figure 3 Installation of the first HER arc cell with operating Cu vacuum chamber. A prototype LER raft is mounted above.

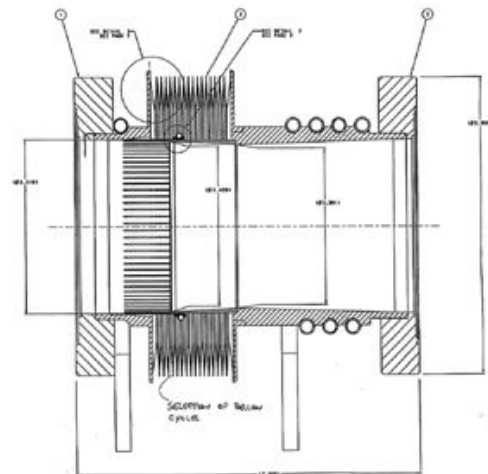
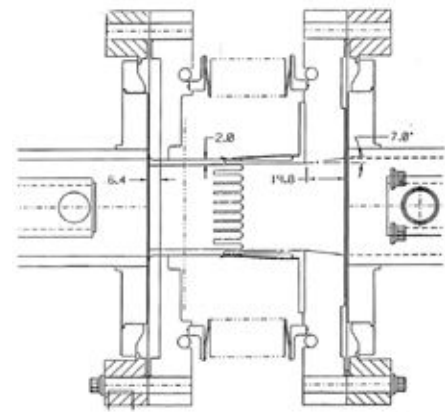
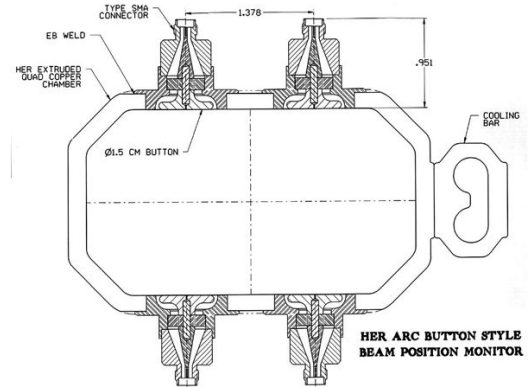
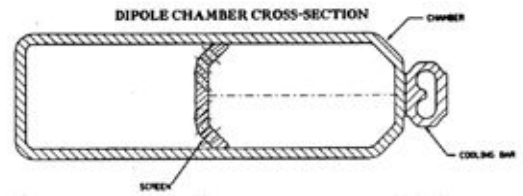

Figure 4 HER Vacuum chambers: a) dipole , b) quadrupole, c) arc bellows, and d) straight section bellows.

### III. LOW ENERGY RING

The LER has an energy range of 2.1 to 4.0 GeV and is designed to store up to 3 A of positrons. All the magnets will be new. The dipole magnets are short (0.45 m) to enhance the radiation damping and beam emittance. The quadrupoles will be built with two piece laminations. The magnet designs were recently completed and orders have been placed for most of the dipoles and quadrupoles. The first prototypes will arrive in summer of 1995.

Two special wiggler chicanes are placed in the LER to provide emittance control. Only one of the chicanes will be implemented with a full wiggler on startup.

The LER vacuum system has aluminum extrusions with ante-chambers in the arcs, stainless steel pipes in the straights, and special copper chambers in the wiggler regions. The chamber cross sections are shown in Figure 5. The aluminum chambers are similar to the ALS design at LBL. The radiation from the LER beam strikes an angled copper photon stop in the ante-chamber with a TSP pump below. This arrangement reduces the average gas pressure around the ring increasing the beam life time. The aluminum extrusions have been through design reviews and one of two designs has been ordered.

The LER lattice has a 90 degrees per cell phase advance with a non-interleaved sextupole chromatic correction scheme in the arcs far from the IR with semi-local chromatic corrections near the IR. An octupole scheme to adjust the amplitude dependent tune shift has been designed.

### IV. INTERACTION REGION

The layout of the interaction region is shown in Figure 6. The HER remains in the horizontal plane and is nearly straight. It has a few dipoles to make a 15 mrad angle at the interaction point to allow the two beams to collide head-on. Vertical dipoles are used in the LER to lower the ring the 0.8 m to the HER plane. Additional horizontal dipoles in the LER are used to provide the proper angle at the IP and to allow for chromatic corrections. In Figure 7 is shown the +/- 7 m region about the IP where the permanent magnet dipole B1 and quadrupole Q1 are used to separate the beams. At the first parasitic crossing the horizontal beam displacement is about  $12 \sigma_x$ , adequate to ameliorate the beam-beam effect. The vacuum chambers in the IR region are primarily copper to mask and absorb the radiation power. At the collision point there will be a water cooled Be beam pipe. The detector solenoid field of 1.5T makes it difficult to correct the coupling in the LER and affects the beam trajectories at the millimeter level in the near IR.

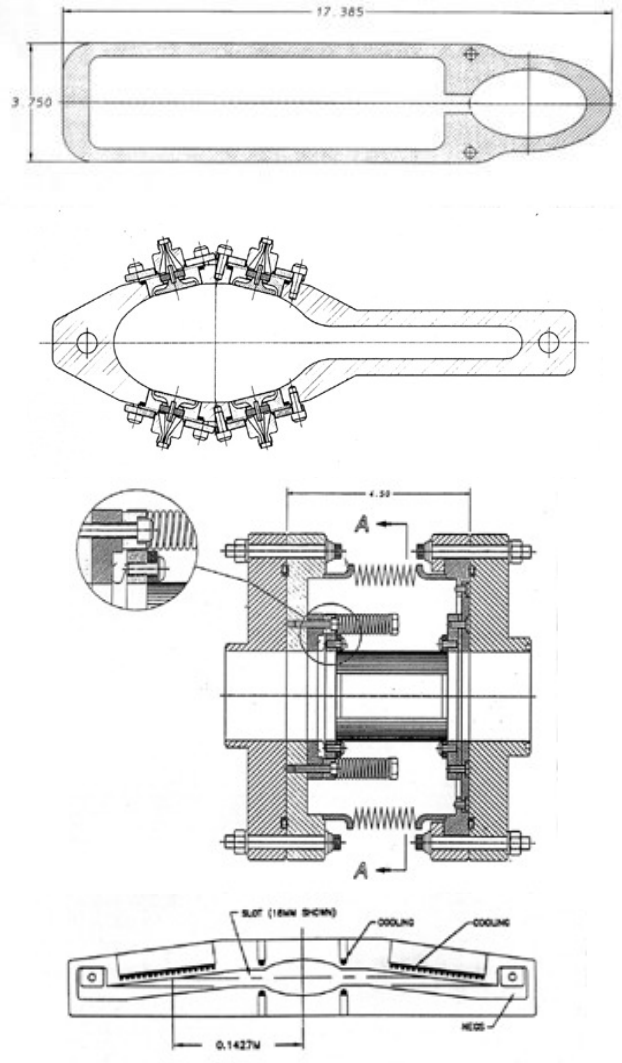

Figure 5 LER vacuum system: a) pumping chamber, b) magnet chamber, c) arc bellow section, and d) wiggler chamber.

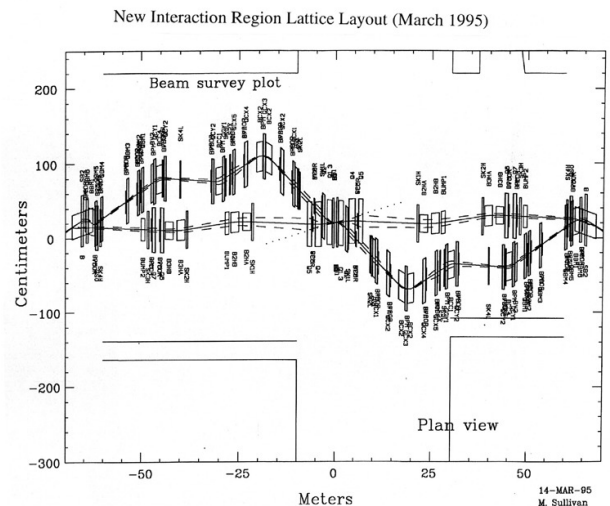

Figure 6 Interaction region lattice layout.

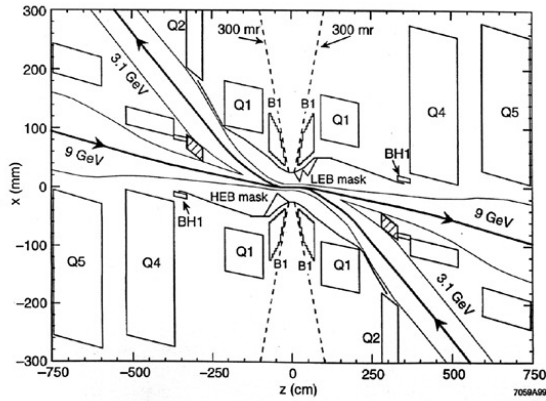

Figure 7 Beam separation at the interaction point.

## V. RF SYSTEM

The PEP-II RF systems must support large beam currents 3A in the LER and 1A in the HER, which drives the design. The unique aspects of the klystrons needed for PEP II are the required short delay time of about 150 nsec, a large bandwidth of 3 MHz, and an output power of 1.2 MW. The short delay and band width are needed to provide for feedback of beam loading and longitudinal coupled bunch instability. One of these klystrons has been built at SLAC and has recently started tests (see Figure 8). The remainder of the required klystrons for PEP II will be made in industry.

The RF cavities for PEP II will be copper single cells with three higher order mode damping ports and an aperture coupler. The cavities are designed for 120 kW operation but will be used in PEP II at 80kW or less. The assembly raft with the cavity, the window, and pump is shown in Figure 9. The first production cavity is in machining as shown in Figure 10. This first cavity is nearing completion and will be under full high power tests by mid-summer 1995.

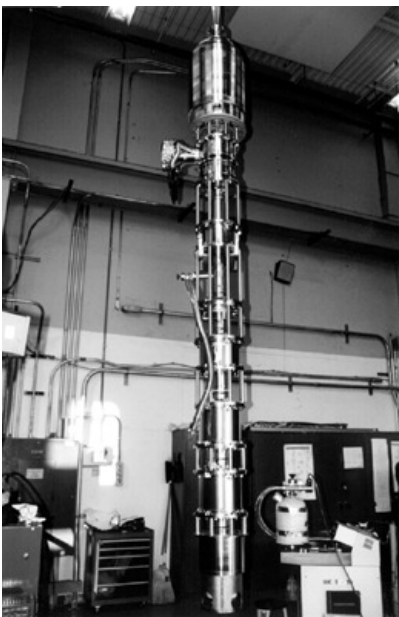

Figure 8 Klystron (1.2MW) before bake.

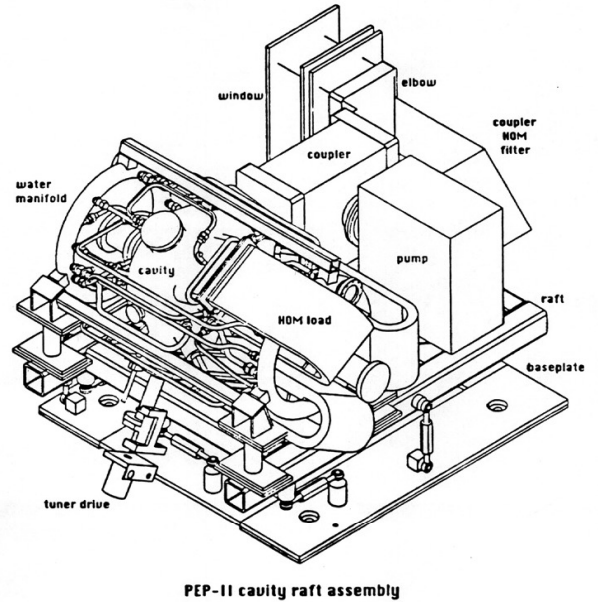

Figure 9 PEP II cavity raft assembly.



Figure 10 RF cavity during machining of water cooling grooves.

The high power cavity window is made from a circular alumina ceramic. Full scale prototype windows have been made and are in test. A power of over 400 KW have been successfully passed through the window while under vacuum and over 500 KW with nitrogen.

High power tuners are being designed after the successful PEP tuners with modification required of the sliding RF contacts.

## VI. FEEDBACK SYSTEMS

The prototypes for the bunch-by-bunch transverse and longitudinal feedback systems for PEP II to be used to control multi-bunch instabilities down to 1 msec growth times are under test in the ALS at LBL. The tests are going very well. After a few final experiments, the full PEP II production of the required beam pickups, digital electronics, amplifiers and kickers will start. The interfaces of these fast digital processors with the PEP II control system are important and under study.

## VII. CONTROLS

The control system for PEP II will be an extension of the working and elaborate SLC control system. This VAX-Microcomputer-CAMAC based system will be extended into the PEP II tunnel to provide basic control as well as proven high level application data taking and software analysis. Integration with linac injection is thus automatic. These controls will be broadened by adding VXI control of the PEP II fast bunch by bunch feedback and RF systems using EPICs. The SLC timing system will provide pulse control with an additional modified trigger module for the PEP ring turn-to-turn needs, such as the position and charge monitors.

## VIII. POWER CONVERSION

The large, intermediate, and small power supplies will be controlled via BITBUS through a digital controller local to the power supply. The large magnet string supplies will use the (massively reworked) existing chopper supplies. The intermediate power supplies are switching units used to power strings of a few quadrupoles. The small supplies power sixteen corrector magnets using a modified controller to handle all simultaneously. The controllers are designed to allow magnet ramping for configuration changes with stored beam.

## IX. STATUS

The PEP II project is off to a fast start due to the hard work of our staff at the three laboratories. Since the linac is operational throughout our construction phase, we will commission our beam lines as soon as they are ready. The electron extraction line from the linac and the mile long bypass line will be tested with beam in the fall of 1995. The HER is to be complete in spring 1997 and injection and storage tests will then begin. The LER is to be finished in spring 1998 with storage tests to follow. First collisions are planned to be achieved in summer of 1998. The BABAR detector is planned to be placed on-line in early 1999.

## X. REFERENCES

- [1] "PEP II Conceptual Design Report," LBL-PUB 5379, SLAC-418, CALT-68-1869, UCRL-ID-114055, UC-IIRPA-93-01, June 1993.
- [2] "BABAR Technical Design Report," SLAC-R-95-457, March 1995.
- [3] M. Zisman and R. Yourd, "Design of the PEP II Low-Energy Ring," PAC, Dallas, May 1995.
- [4] U. Wienands, et al, "Design of the High Energy Ring of the PEP II B Factory," PAC, Dallas, May 1995.
- [5] D. Hunt, et al, "Design of the PEP II Low Energy Ring Vacuum System," PAC, Dallas, May 1995.
- [6] T. Henderson, et al, "Design of the PEP II Low Energy Ring Arc Magnets," PAC, Dallas, May 1995.
- [7] W. Barry, et al, "Design of the PEP II Transverse Coupled-Bunch Feedback System," PAC, Dallas, May 1995.
- [8] J. Fox, et al, "Operation and Performance of the PEP II Prototype Longitudinal Damping System at the ALS," PAC Dallas, May 1995.
- [9] A. Kulikov, et al, "The PEP II High Power Dumping System," PAC, Dallas, May 1995.
- [10] U. Wienands, et al, "The Vacuum System for the PEP II High Energy Ring Straight Sections," PAC, Dallas, May 1995.
- [11] C.-K. Ng, et al, "Simulation of the PEP II Beam Position Monitors," PAC, Dallas, May 1995.
- [12] S. Heifets, et al, "Impedance Budget of the PEP II B Factory," PAC, Dallas, May 1995.
- [13] X. Lin, et al, "Impedance Spectrum for the PEP II RF Cavity," PAC, Dallas, May 1995.
- [14] Y. Cai, et al, "Low Energy Ring Lattice of the PEP II," PAC, Dallas, May 1995.
- [15] M. Donald, et al, "Lattice Design for the High Energy Ring of the B Factory (PEP II), Dallas, May 1995.
- [16] Y. Yan, et al, "Nonlinear Analyses of Storage Ring Lattices using One-Turn Maps," PAC, Dallas, May 1995.
- [17] F. Zimmerman, et al, "Trapped Macroparticles in Electron Storage Rings," PAC, Dallas, May 1995.
- [18] Y. Nosochkov, et al, "Detector Solenoid Compensation in the PEP II B-Factory," PAC, Dallas, May 1995.
- [19] L. Jackson, et al, "PEP II Magnet Power Conversion Systems," PAC, Dallas, May 1995.
- [20] T. Fieguth, et al, "PEP II Injection Transport, Construction Status and Commissioning Plans," PAC, Dallas, May 1995.
- [21] R. Rimmer, et al, "Development of a High-Power RF Cavity for the PEP II B Factory," PAC, Dallas, May 1995.
- [22] W. Fowkes, et al, "1.2 MW Klystron for Asymmetric Storage Ring B Factory," PAC, Dallas, May 1995.
- [23] A. Chan, et al, "The PEP II Project-Wide Database," PAC, Dallas, 1995.