

Operating Experience with High Beam Currents and Transient Beam Loading in the SLC Damping Rings*

M. G. Minty, R. Akre, P. Krejcik, R. H. Siemann
Stanford Linear Accelerator Center, Stanford University, Stanford, CA 94309 USA

During the 1994 SLC run the nominal operating intensity in the damping rings was raised from 3.5×10^{10} to greater than 4×10^{10} particles per bunch (ppb). Stricter regulation of rf system parameters was required to maintain stability of the rf system and particle beam. Improvements were made in the feedback loops which control the cavity amplitude and loading angles. Compensation for beam loading was also required to prevent klystron saturation during repetition rate changes. To minimize the effects of transient loading on the rf system, the gain of the direct rf feedback loop and the loading angles were optimized.

I. INTRODUCTION

Modifications to the SLC damping ring rf systems have been required as the beam intensities and beam environment change. During the 1992 run, beam intensities were limited to 3×10^{10} ppb by the microwave instability.¹ In 1993 this instability was overcome using an rf voltage ramp with direct rf feedback,² and the beam current was increased to 3.5×10^{10} ppb.³ Prior to the 1994 run, low impedance vacuum chambers were installed to reduce the impedance of the damping rings.⁴ By reducing the effects of the microwave instability, the beam current could be increased. Transient loading on the rf system, however, occasionally caused loss of regulation of the cavity voltage.⁵ As a result, both the bunch length and the beam phase changed at extraction. Such changes caused unacceptable wakefield-induced emittance growth and beam jitter in the linear collider. Stricter tolerances on cavity voltage regulation were therefore required at higher operating currents. With modifications to the feedback loops, beam currents were increased to over 4.0×10^{10} ppb. Some operating parameters for the SLC damping rings are given in Table I.

Table I. Cavity, Beam, And Klystron Properties In The SLC Damping Rings For The Past Three Runs

Symbol	Variable	1992	1993	1994
V_c (MV)	Cavity Voltage	0.80	1.00	0.80
I_b (A)	rf Beam Current = $2 \times$ dc Current	0.16	0.19	0.22
N ($\times 10^{10}$)	Particles per Bunch	3	3.5	4.0 - 4.5
P_{max} (kW)	Max. Klystron Output Power	50	60	50
ϕ_z (deg)	Tuning Angle	-45	-43	-49
ϕ_l (deg)	Loading Angle	0	0	10

II. FEEDBACK REGULATION

A block diagram of the SLC damping ring rf system is shown in Fig. 1. The cavity voltage is maintained at the desired value V_{des} by the amplitude feedback loop. The beam phase is regulated to ϕ_{des} by the phase feedback loop. The phase offset ϕ_{inj} is the offset required to match the injected beam to the damping ring bucket. Likewise ϕ_{des} is adjusted to match the extracted beam to the accepting bucket of the linear accelerator. The direct rf feedback loop, which was used previously to avoid the beam loading instability,³ is currently used to minimize the effects of transient loading (see section IV). Not shown in Fig. 1 are the slow cavity tuner loops which regulate the loading angle ϕ_l . The loading angle is the measured phase difference between the generator current and the cavity voltage which is different from the tuning angle ϕ_z at high beam current.

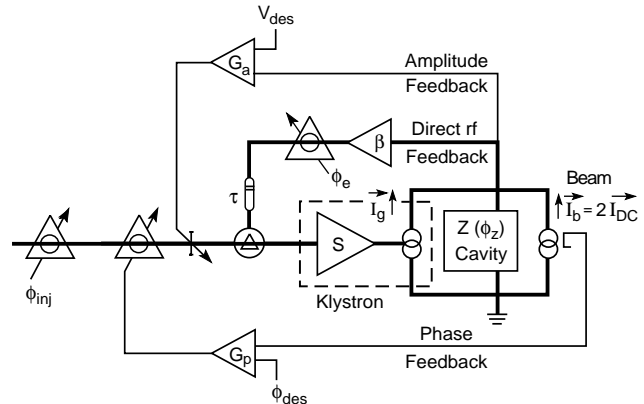

Figure 1. The SLC damping ring rf system. Included are amplitude, beam phase, and direct rf feedbacks. The thick lines indicate paths for phasors with both phase and amplitude.

Amplitude Feedback Loop

The open loop gain of the amplitude feedback loop contains a number of nonlinear elements including a nonlinear power limiter and a nonlinear klystron. This gain can therefore change depending upon the operating power of the klystron which in turn depends both on the beam current and the cavity voltage. Problems with cavity voltage regulation were observed when running either high beam currents or high cavity voltage. These were found to be due to a low open loop gain, which resulted in the closed loop gain of the loop becoming dependent on the open loop gain. When the open loop gain changed, regulation was affected as

* Work supported by the Department of Energy, contract DE-AC03-76SF00515.

a result. The problem was corrected by increasing the open loop gain.

Tuner Feedback Loops

Until recently the cavity tuners were not carefully regulated. Difficulties arising from beam-related heating of the rf cavities however have necessitated careful control. The tuners, which regulate the phase between the generator and cavity voltages, are sampled and held once per cycle. Initially the tuner dead band was about 8° which was limited by the noise level in the phase measurement. To improve the signal-to-noise ratio, a filter was added after the sample and hold module which allowed the dead band to be reduced to 1° . The speed of the tuners, motor-driven tuning plungers, has also been decreased to prevent oscillations. These modifications resulted in a greater degree of stability in the loading angle. Occasional problems related to loss of regulation, however, still persist upon recovery from an extended period without beam.

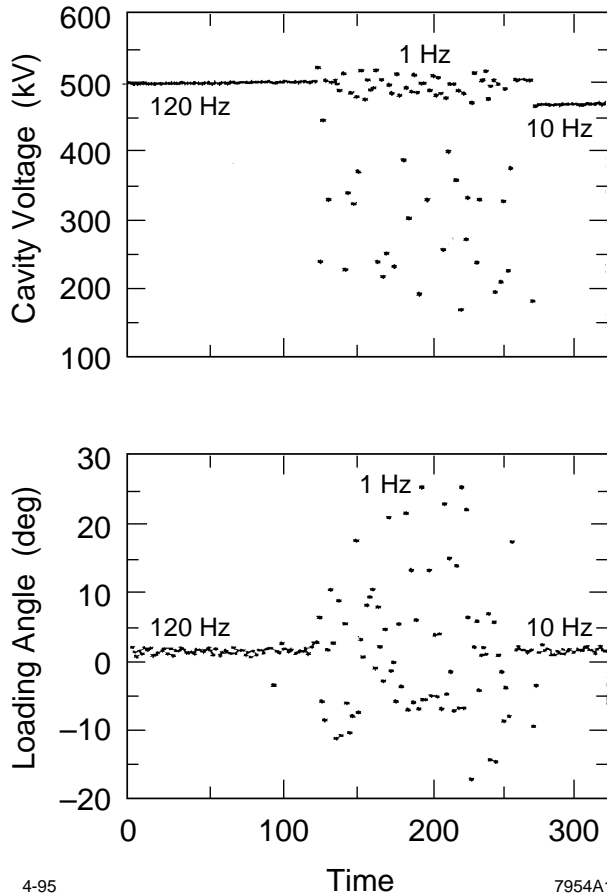

4-95
7954A1
Figure 2. Measured cavity voltage and loading angle during rate limiting.

III. COMPENSATION FOR REPETITION RATE CHANGES

To avoid damage to accelerator components from beam heating, the repetition frequency is occasionally reduced

from 120 Hz to 10 Hz or 1 Hz. At low rate the slow tuner feedback loops could respond to changes in the loading angle. As shown in Fig. 2 the tuner positions and cavity voltage lost regulation under 1 Hz operation. In this example the loading angle was nominally regulated to $\phi_l = 0^\circ$ while the tuning angle, the phase between the voltage and the current, was $\phi_z = -45^\circ$. When the beam was extracted therefore, the tuners would move and the cavity would be unregulated at injection. To avoid this, a beam-presence condition was added which fixed the tuner positions in the absence of beam.

With direct rf feedback, the long absence of beam due to rate limiting also caused problems. Because the instantaneous power requirements are higher with direct rf feedback, a limiter just upstream of the klystron was added to prevent klystron saturation in the 1993 run. Initial high current experiments at the end of the 1993 run showed that simple limiting was insufficient for maintaining stability during rate-limiting at even higher beam currents. Instead, an intermediate level voltage was summed with the reference input to the amplitude feedback loop (V_{des} in Fig. 1) during rate-limiting.

IV. MINIMIZATION OF TRANSIENT LOADING EFFECTS

With the steady-state defined by operation with beam, the dominant transient loading effects are caused by injection and extraction of the beam.^{5,6} Because direct rf feedback effectively deQ's the cavity and therefore decreases the cavity fill time, this feedback proved useful in minimizing the effect of beam loading since the rf system is rapidly able to compensate for the fast changes. Without direct rf feedback and with high currents substantial beam losses resulted from the large cavity voltage oscillations induced by injection. Transients in the cavity voltage are shown in Fig. 3 with the direct rf feedback loop off ($G = 0$ dB) and on ($G = 20$ dB). Beam extraction is indicated by the initial discontinuity near $30 \mu s$. The next discontinuity $13 \mu s$ later corresponds to beam injection. Without direct rf feedback the voltage oscillated by about 400 kV peak-to-peak. With $G = 20$ dB the oscillations were reduced to 220 kV peak-to-peak. Numerical analysis results showing the effect that direct rf feedback has in reducing these transient oscillations are presented in Ref. 5.

Transient oscillations may be further reduced by ensuring that the beam is properly injected into the center of the rf bucket. The beam phase at extraction is regulated by feedback to ensure proper injection into the linear accelerator. At extraction the rf phase is reset to prepare for injection which is $13 \mu s$ later. The phase at injection is a relative phase offset between the damping ring and injection linac. Typically this phase offset (ϕ_{inj} in Fig. 1) is checked periodically and adjusted by minimizing the amplitude of the transient oscillations while viewing the rf waveform on an oscilloscope.

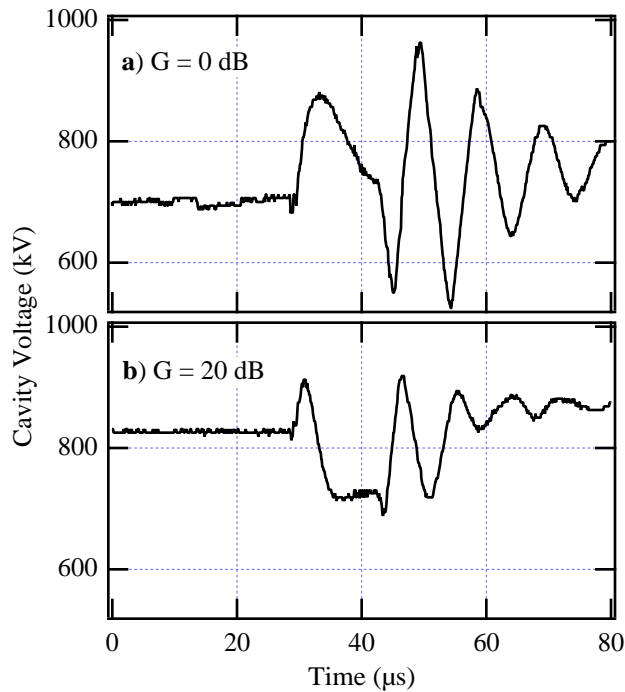

Figure 3. Cavity voltage with two different direct rf feedback gains. $\phi_l = 0^\circ$; $\phi_{inj} = 45^\circ$.

Finally, transient oscillations were minimized by intentional detuning of the loading angle. As shown in Fig. 3 a large voltage error on the accelerating cavity resulted when the direct rf feedback loop was on. By adjusting the tuner feedback loop set point to positive loading angle under nominal conditions with beam, this problem was alleviated. Transient oscillations in the cavity voltage are plotted as a function of time with direct rf feedback on at different loading angles in Fig. 4. As the loading angle increased, the amplitude of the transients decreased as expected.⁵ In the first two plots, when the beam was extracted the cavity voltage was not maintained. As a result, the voltage at injection was out of regulation. At $\phi_l = +10^\circ$ the voltage was regulated when the beam was absent. At $\phi_l = 23^\circ$ the cavity voltage was already out of regulation before the beam was extracted. At extraction the cavity voltage increased towards its regulated value

V. SUMMARY

Modifications to the rf systems in the SLC damping rings were required to overcome instabilities related to heavy beam loading. The rf system was tuned to minimize transient beam loading effects. For future running at higher beam currents, we will try to ensure that the klystron is capable of operating at higher power levels (as in 1993). Modifications to the amplitude feedback hardware and logic are also being considered to provide better stability.

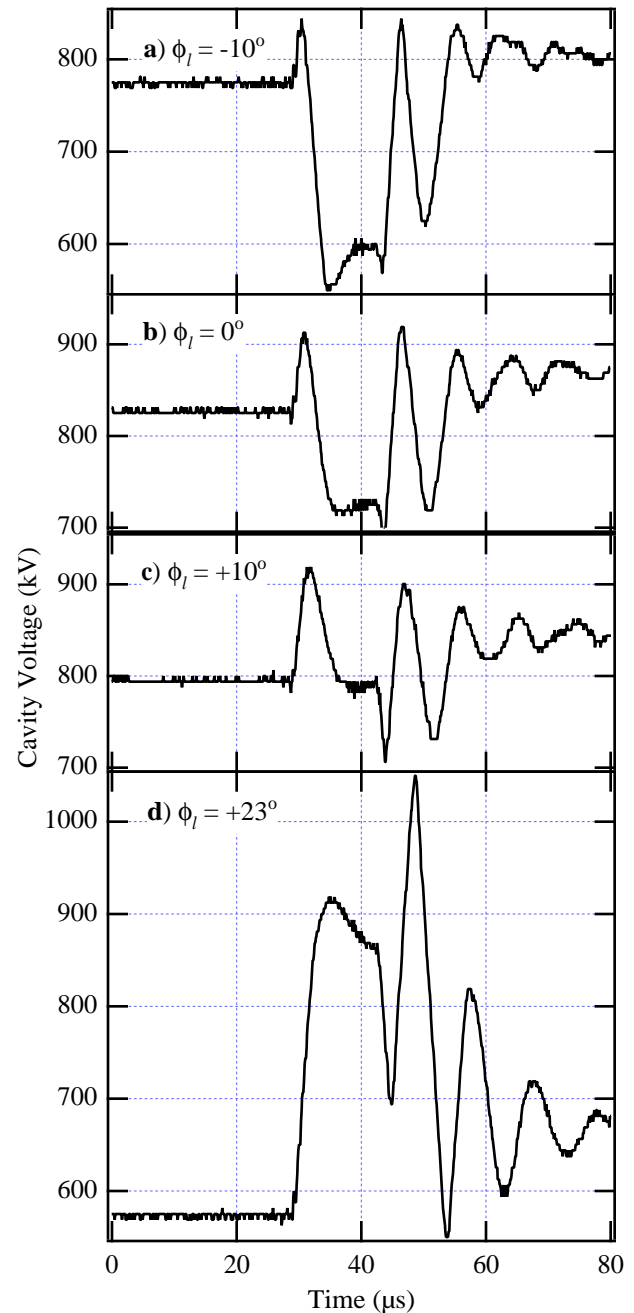

Figure 4. Cavity voltage as a function of time with $G = 20$ dB and variable loading angle ϕ_l . $\phi_{inj} = 45^\circ$.

VI. REFERENCES

1. P. Krejcik *et al*, *Proc 1993 PAC*, 3240 (1993).
2. F. Pederson, *IEEE Tran. on Nucl. Sci.*, NS-32, 2138 (1985).
3. P. Krejcik *et al*, *Proc 1993 PAC*, 2370 (1993).
4. K. Bane *et al*, *WAC17 1995 PAC*.
5. M. Minty & R.H. Siemann, *TPA09 1995 PAC*.
6. M. Minty & R.H. Siemann, *RAP10 1995 PAC*.