

RF System for the NSLS Coherent Infrared Radiation Source *

W. Broome, R. Biscardi, J. Keane, P. Mortazavi, M. Thomas, J.M. Wang
Brookhaven National Laboratory, Upton, NY 11973

I. ABSTRACT

The existing NSLS X-ray Lithography Source (XLS Phase I) is being considered for a coherent synchrotron radiation source. The existing 211 MHz warm cavity will be replaced with a 5-cell 2856 MHz superconducting RF cavity, driven by a series of 2 kW klystrons. The RF system will provide a total V_{RF} of 1.5 MV to produce $\sigma_L = 0.3$ mm electron bunches at an energy of 150 MeV. Superconducting technology significantly reduces the required space and power needed to achieve the higher voltage. It is the purpose of this paper to describe the superconducting RF system and cavity, power requirements, and cavity design parameters such as input coupling, Quality Factor, and Higher Order Modes.

II. INTRODUCTION

The XLS Phase I storage ring is a compact racetrack-shaped ring at the National Synchrotron Light Source of Brookhaven National Laboratory. Using a warm 211 MHz RF cavity, currents of up to 0.75 A in 6 bunches have previously been stored at energies ranging from 120 to 200 MeV. Installation of a 5-cell 2856 MHz superconducting cavity will provide an accelerating voltage of 1.5 MV for an average current of up to 5 mA, and create a source of coherent synchrotron radiation with 0.3 mm bunches at an energy of 150 MeV [1]. In order to accommodate the cavity, cryostat and helium vessel, and other associated hardware, the circumference of the ring can be increased to ~ 9.66 from the present 8.5 m by adding a short straight section on both sides, keeping modification costs to a minimum. A partial list of the ring and RF parameters is presented in Table 1.

Table 1. Proposed Ring and RF Parameters

Energy, E	150	MeV
Circumference	9.66	m
Momentum Compaction, α	0.322	
Energy Loss per Turn, U_0	74	eV
Beam Current, I_{AV}	5	mA
RF Frequency	2856	MHz
Peak Cavity Voltage, V_{CAV}	1.5	MV
R_{SH}/Q	240	Ω
Unloaded Quality Factor, Q_0	10^9	
Synchronous phase, Ψ_V	89.997	degrees
$P_{RAD} \equiv I_{AV} U_0$	370	mW
$P_{CAV} \equiv V^2 / 2R_{SH0}$	4.69	Watts
$\rho \equiv P_{RAD} / P_{CAV}$	0.2	

III. CRYOGENICS

The system will use a helium reservoir, operating at 2° K, rather than circulating refrigeration because of the high initial

capital cost of a closed cycle system [Figure 1]. Initially, the cryostat will be filled with normal helium; the 2° K operating temperature will be achieved through cryo-pumping. Although it is rather large, the “top-filled” cryostat is relatively easy to operate and is capable of supplying enough helium for 8 continuous hours of operation. The main difficulties foreseen are with the assembly sequences. The RF cavity will have protective windows and valves as safeguards after cleaning.

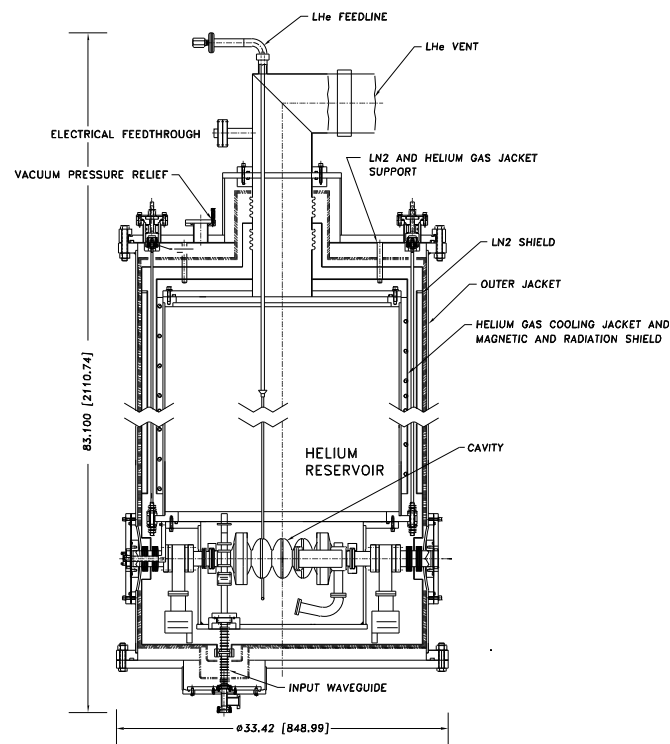

Figure 1. Superconducting Cavity and Helium Reservoir

IV. CAVITY DESIGN

The cavity design [Figure 2] is being adapted and scaled from that currently in use at Cornell and CEBAF [2,3,4], including the input waveguide and the HOM couplers. There are 5 elliptical cells operating in the π mode. Scaling of CEBAF results to a 2856 MHz cavity indicates that a gradient of 8.9 MV/m is achievable. With an active length of 0.262 m, a peak cavity voltage, V_{CAV} of 2.3 MV can be reached, which is 50% greater than specified. The order of magnitude of the unloaded quality factor Q_0 , is approximately 10^9 .

A. Input Coupling

As in the CEBAF design, RF power is propagated in the TE_{10} mode through a rectangular waveguide. A hole in the broad wall of the waveguide that is aligned with the beam tube,

* Work performed under the auspices of the US Department of Energy

provides coupling to the accelerating cavity. The waveguide continues past the coupling hole, into a shorted stub whose length can be varied to change the standing wave pattern at the coupling aperture and whose width is reduced to aid in damping of certain HOMs [2]. This method of coupling will provide a Q_{EXT} in the range of 10^4 to 10^8 .

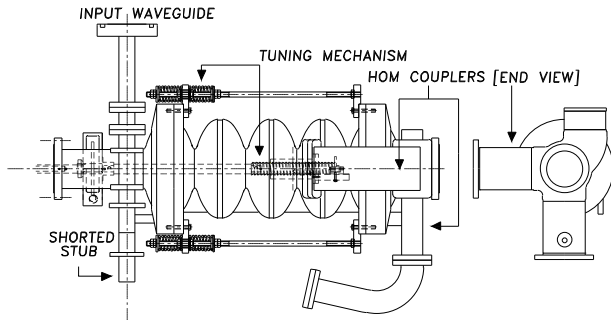

Figure 2. 2856 MHz niobium cavity indicating input waveguide, HOM couplers, and tuning mechanism.

B. Tuning

The cells will be tuned at room temperature by inelastically stretching or compressing the cells axially with plates that grip the equatorial region as illustrated in Figure 2. Compensation will be made for frequency shift due to thermal contraction, chemical treatment, pressure differential, and dielectric constant differential.

V. HIGHER ORDER MODES

A. Mode Damping

In such high Q factor structures as superconducting cavities which store energy so effectively, it is particularly important to damp beam-induced HOMs. A summary of monopole TM modes below the URMEL-calculated cutoff of 6245 MHz, and dipole modes below the URMEL-calculated TE cutoff of 4628 MHz is presented in Table 2.

Table 2. HOMs as calculated by URMEL

Monopoles [MHz]	R/Q (Ω)	Dipoles [MHz]	R/Q (Ω at R_0)
2834.54	243.26	3320.47	0.32
5201.39	0.01	3392.72	0.96
5239.93	1.89	3501.47	19.82
5300.34	0.10	3629.86	73.31
5381.47	13.59	3787.95	39.96
5474.68	54.88	3819.17	0.26
5587.89	0.06	3972.62	18.70
5680.19	7.56	4006.32	28.80
5764.53	0.12	4024.02	4.38
5818.99	0.92	4025.61	4.16
5852.78	0.07		

The limited diameter of the beam pipe aperture at the cavity and space constraints for heat removal, will not allow placement of RF absorbing ferrite material inside the pipe as is used at MIT-Bates [5]. Therefore, as in CEBAF, rectangular waveguide ports at the opposite end from the input port serve as two right angle HOM couplers. The HOM coupler includes a shorted stub that assists in the control of mode polarization.

B. HOM Power

The typical Q_{EXT} obtained by HOM couplers is in the 10^4 range [6]. These findings are corroborated by the HOM measurements made by CEBAF. In order to reduce the consumption of liquid helium and to keep the time between fills at a maximum, plans call for the HOM couplers to be terminated in helium gas - within the reservoir but above the level of the liquid.

HOM power calculations were made by placing each of the modes on the nearest unstable sideband of a rotation line. Using the relationship

$$P_{HOM} = \left[2 \frac{I_{AV}}{\sqrt{2}} e^{-\frac{(\omega\sigma_r)^2}{2}} \right]^2 R_T$$

with a bunch length, σ_r , of $1.6e-12$ s, and an average beam current of 5 mA, the sum of the maximum power deposited by monopoles is < 4 W, and by dipoles < 5 W (0.25 cm off-axis). Based on CEBAF's experience, the actual power coupled from the HOMs is expected to be much less than maximum.

VI. RF POWER SOURCE REQUIREMENTS

Sizing of the RF power source for the superconducting cavity is not an obvious choice. From Table 1, $R_{SH0} = R/Q \times Q = 2.4 \times 10^{11} \Omega$, $P_{RAD} + P_{CAV} = 5.8$ W, and $P_{REACTIVE} = V_{CAV} \times I_{AV} = 7.5$ kW.

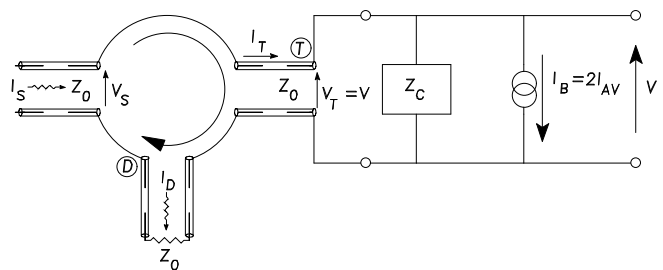

Figure 3. Equivalent Circuit Model of the RF System

The equivalent circuit of the RF system [7] is illustrated in Figure 3, where I_s is the forward source current from the klystron, and I_D is the reflected current which is dissipated through Port D into a dummy load.

The size of the power source assumes that no fast tuner is required and that klystron power and phase are adjusted to compensate for beam loading. Obviously, the majority of the forward power is reflected and absorbed by the waster load of the circulator that has the added advantage of reducing Q_L , thereby increasing the loaded bandwidth, B_L . The amount of “de-Q-ing” is dependent on the transformer ratio N , the coupling transmission ratio between the waveguide and the cavity. From [7] and [8], if the cavity structure is left on resonance, P_S can be expressed as

$$P_S = \frac{I_S^2}{2} Z_0 = \left[\left(\frac{V_{CAV}}{2Z_0 N} \right)^2 + \left(\frac{I_B N}{2} \right)^2 \right] \frac{Z_0}{2},$$

where I_B is $2 I_{AV}$ and N is the coupling transformer ratio. It is assumed that the coupling factor, $\beta = R_{SH} / (N^2 Z_0) \gg 10$. From this equation, an optimum value of N for a minimum P_S can be calculated. Once N is selected, the following observations can be made:

- The reactive component of the generated voltage to compensate for beam is equal to but in quadrature with the accelerating voltage.
- The power variation from zero to full beam is 2:1, while the incident voltage phase shift is 45° .
- The maximum P_S required is half the reactive beam power loading.

If $N \gg N_{critical}$, the beam induced reactive component requires excessive compensating generator power. If $N \ll N_{critical}$, the generator power required to establish the accelerating field is excessive.

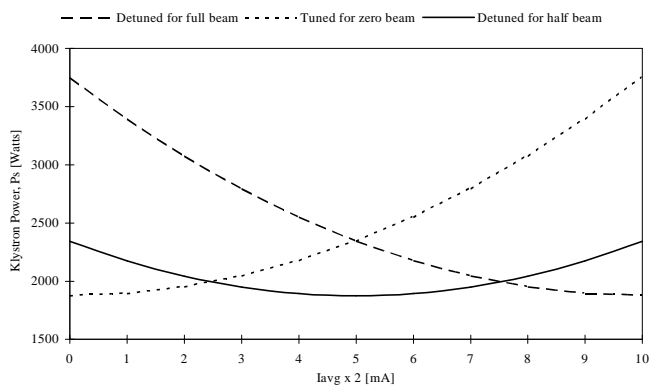

Figure 4. Klystron power required vs beam current

For $V_{CAV} = 1.5$ MV and $I_{AV} = 5$ mA, $N_{CRITICAL} = 6.9 \times 10^4$ and $N = 1.7 \times 10^3$ at $P_{S[minimum]}$. Under these conditions, the required $P_S = 1.875$ kW at $I_B = 0$, and increases to 3.75 kW at $I_B = 10$ mA. The corresponding $Q_L = 6.25 \times 10^5$, and $B_L = 4.57$ kHz. P_S vs I_B is illustrated in Figure 4.

If the cavity is detuned for the full beam reactive power prior to injection with the same coupling factor, $P_S = 1.875$ kW at $I_B = 10$ mA. However, at $I_B = 0$, $P_S = 3.75$ kW if $V_{CAV} = 1.5$ MV is to remain constant. Furthermore, if the cavity detune is preset to compensate for HALF of the full beam reactive power, the generator would be required to deliver 2.34 kW at

$I_B = 0$ and $I_B = 10$ mA, with a minimum of 1.875 kW at $I_B = 5$ mA. These 3 detuning scenarios are illustrated in Figure 4. Further reduction of P_S is possible if the requirement of $V_{CAV} = 1.5$ MV is relaxed at $I_B = 0$. In that case, detuning could be set to compensate for a value $> 0.5 P_{REACTIVE}$.

The most convenient klystron package available is 2 kW. Although easily obtainable, these units have a long lead time and it seems appropriate to buy 2 units for a total combined power source of 4 kW. This will provide adequate power and at the same time build flexibility into the system. If higher currents are required, the system could be easily expanded. Also, if one unit should fail, the other could supply enough power for nearly full current. This could be accomplished with a combination of coupling modification, presetting the cavity tune [Figure 4], or relaxation of the gap voltage at injection. Suitable modifications must be made to the klystron power and phase during injection.

VII. CONCLUSION

The design parameters and behavior of a 2856 MHz superconducting cavity and the corresponding RF power requirements for the NSLS Coherent Radiation Source have been discussed. Results indicate that with relatively minor changes to the XLS Phase I ring, the addition of the superconducting system can provide the large RF voltage necessary for the generation of sub-millimeter wave coherent synchrotron radiation.

VIII. ACKNOWLEDGMENTS

We would like to thank Ron Sundelin, Julie Oyer and the staff of CEBAF as well as James Murphy of NSLS for their valuable insights, contributions, and patience.

IX. REFERENCES

- [1] J.B. Murphy, S. Krinsky, Nucl. Instr. and Meth. in Phys. Res. A 346 (1994) 571-577.
- [2] R. Sundelin, “Application of a 2856 MHz Superconducting Cavity at BNL”, NSLS presentation and private communications (1994).
- [3] M. Dzenus et al., Proc. IEEE Part. Acc. Conf. (1991), 2390-2392.
- [4] P. Kneisel et al., Proc. IEEE Part. Acc. Conf. (1991), 2384-2386.
- [5] M.S. de Jong et al., Proc. IEEE Part. Acc. Conf. (1993), 832-834.
- [6] H. Padamsee, “Superconducting RF”, AIP Conf. Proc. Vol. 2, The Physics of Part. Accelerators (1992) 1402-1482.
- [7] W. Broome and J.M. Wang, “RF Power Considerations for XLS Coherent Light Source,” NSLS Tech Note 491 (1994).
- [8] J. Keane, “RF Power Requirements for Highly Reactive Beam Loaded 2856 MHz Superconducting Cavity,” NSLS Tech Note 494 (1995).