

CHARACTERIZATION OF A KLYSTRODE AS A RF SOURCE FOR HIGH-AVERAGE-POWER ACCELERATORS*

D. Rees, D. Keffeler, W. Roybal, and P. J. Tallerico
Los Alamos National Laboratory, Los Alamos, NM 87545 USA

Abstract

The klystrode is a relatively new type [1]–[4] of RF source that has demonstrated dc-to-RF conversion efficiencies in excess of 70% and a control characteristic uniquely different from those for klystron amplifiers. The different control characteristic allows the klystrode to achieve this high conversion efficiency while still providing a control margin for regulation of the accelerator cavity fields. We present test data from a 267-MHz, 250-kW, continuous-wave (CW) klystrode amplifier and contrast this data with conventional klystron performance, emphasizing the strengths and weaknesses of the klystrode technology for accelerator applications. We present test results describing that limitation for the 250-kW, CW klystrode and extrapolate the data to other frequencies. A summary of the operating regime explains the clear advantages of the klystrode technology over the klystron technology.

I. INTRODUCTION

The klystrode combines attributes from both the gridded-tube and klystron technologies, with an input structure borrowed from gridded-tube technology and a klystron-like output cavity. It is a density-modulated amplifier. Figure 1 is a schematic of the klystrode.

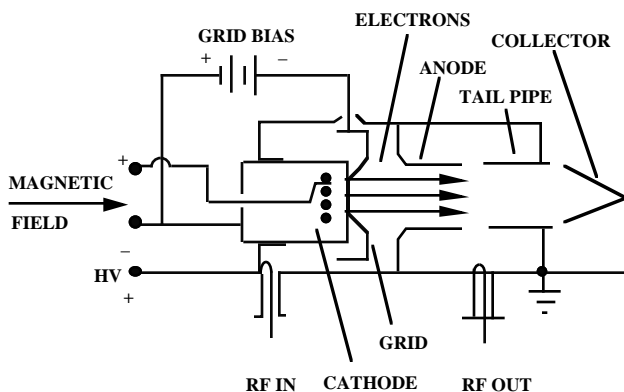

Figure 1: Schematic of the klystrode amplifier tube.

Since the dc acceleration region is separate from the power extraction region in the klystrode, it has transit-time advantages over conventional gridded tubes. Because it is a current-modulated device, the current bunch is more nearly monoenergetic and high efficiencies can be achieved without the stability issues surrounding high-efficiency klystrons. The primary klystrode market is UHF television transmission,

where the klystrode provides up to 60 kW of peak power. Two high-power klystrode developments promise the extension of TV technology to power levels that are of interest to the particle accelerator community. The first development produced a pulsed klystrode at 425 MHz, which achieved in excess of 750 kW peak at a 10% duty factor [1]. The klystrode gain was in excess of 20 dB, and an efficiency greater than 70% was demonstrated. The second high-power klystrode development provided a 250-kW continuous-wave (CW) klystrode at 267 MHz and is the basis for the information presented in this paper [4]. This klystrode was originally developed by Varian for the Chalk River Nuclear Laboratories of Atomic Energy of Canada Limited as a power source for a radio frequency quadrupole accelerating cavity [5]. The program has since moved to Los Alamos National Laboratory, where the system is being used as a test stand for advanced accelerator applications [6]. Our interest in high-power klystrons is motivated by their high efficiency and their control characteristic. All high-power klystrode developments have achieved an efficiency in excess of 70%, which is better than that for klystrons currently in accelerator service; and unlike the klystron, it is possible to modulate the input signal to the klystrode and vary the output while still achieving high efficiency.

In accelerator service, the high-power amplifier is part of a fast control loop, which maintains the accelerating cavity field amplitude and phase at a desired set point. The klystron provides its maximum efficiency only at saturation, where the power transfer curve is essentially flat, making control by amplitude modulation of the drive signal impossible. In order to exercise control over the cavity field, we must typically operate the klystron with a control margin (the amount of operation below saturation) of 10% to 20%. A 20% control margin decreases the efficiency of a klystron operating at 70% efficiency at saturation to 56% at the nominal operating point. In contrast, we demonstrate that the klystrode can provide a relatively constant, high efficiency over the last 30% of its power capability.

One advantage of the klystrode over the klystron is its high gain. In many klystron-based accelerator RF systems a small solid-state amplifier drives a klystron with 45–55 dB of gain. The klystrode gain of 20–22 dB increases transmitter complexity and requires an intermediate amplification stage for high-power applications; however, the klystrode does not require a modulator, as does a klystron, for pulsed service because it is configured as a class B amplifier. When large CW accelerators lose their vacuum, they are often pulse-conditioned, and with klystrons expensive modulators are sometimes built solely for conditioning. Such modulators are not required for the klystrode. Klystrons also have demonstrated much higher peak and average power capabilities than have klystrons.

As an additional advantage of klystron technology, the drive signal is applied to a modulating gap that is not collocated with the cathode surface as is true with the

*Work supported by the United States DOE, contract W-7405-Eng-36.

klystrode. A portion of the klystrode drive power is dissipated on the cathode surface, providing an additional source of cathode heating. Because of the relatively low gain, this characteristic may ultimately limit the average power capability of the klystrode without additional technology advances in the input structure or cathode material.

II. EXPERIMENTAL RESULTS

Data representing the klystrode's linearity, phase variation with output power, efficiency variation with output power, and bandwidth is presented in Figures 2–5. The data was taken at 267 MHz. We integrated power meters, a swept-frequency source, and sampled values of beam current and voltage into a LabVIEW-controlled automated test to generate the power transfer, bandwidth, and efficiency plots. We used a network analyzer to measure the phase variation with input power, which we then converted to a plot of phase variation with output power by using the power transfer characteristic. The klystrode transmitter is a three-stage transmitter with the 250-kW klystrode as the final stage. The data presented here are only for the final klystrode stage. The curves in Figures 2 and 3 illustrate the klystrode power-transfer curve and phase response. Figure 4 shows the klystrode efficiency as a function of output power. Figure 5 illustrates the klystrode bandwidth. Inspection of Figure 4 shows that the klystrode provides almost constant efficiency from 180 to 250 kW. Inspection of Figure 2 shows that the power-transfer characteristic is relatively linear in this region. Taken together, Figures 2 and 4 support the earlier assertion that the strength of the klystrode for accelerator service is its capability to provide simultaneously high efficiency and a control margin for regulating accelerator cavity fields.

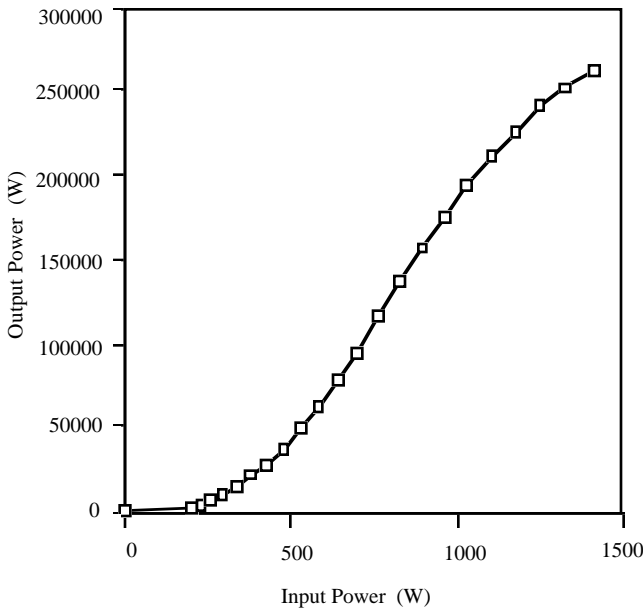

Figure 2: Klystrode power transfer characteristic.

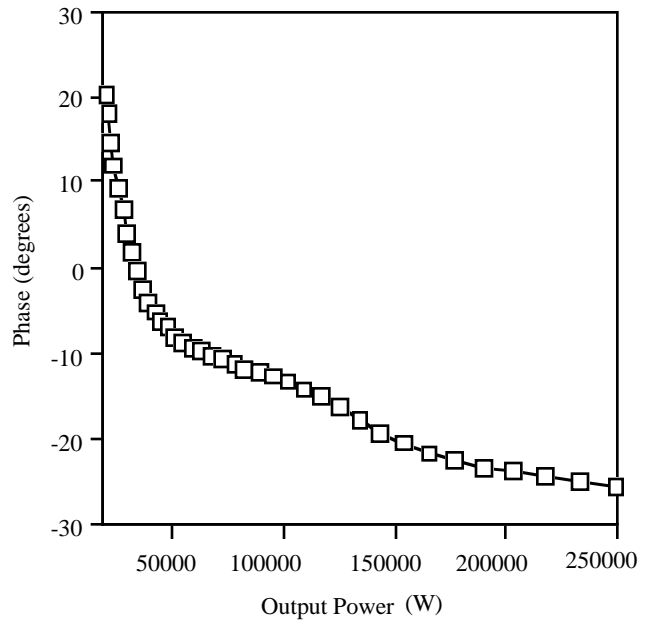

Figure 3: Klystrode phase response.

Figure 6 illustrates the output power versus filament power for the 250-kW klystrode at three nominal output power levels. Tests were performed at nominal output powers of 60 kW, 180 kW, and 234 kW over the filament power range of 175 to 300 W. The filament power was controlled by varying the filament current. The klystrode operates at a nominal value of filament power slightly larger than 250 W (the third data point on each curve).

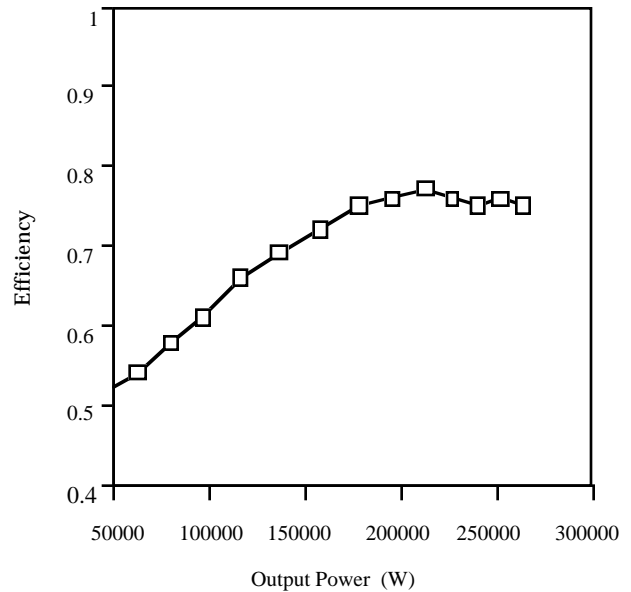

Figure 4: Klystrode efficiency as a function of output power level.

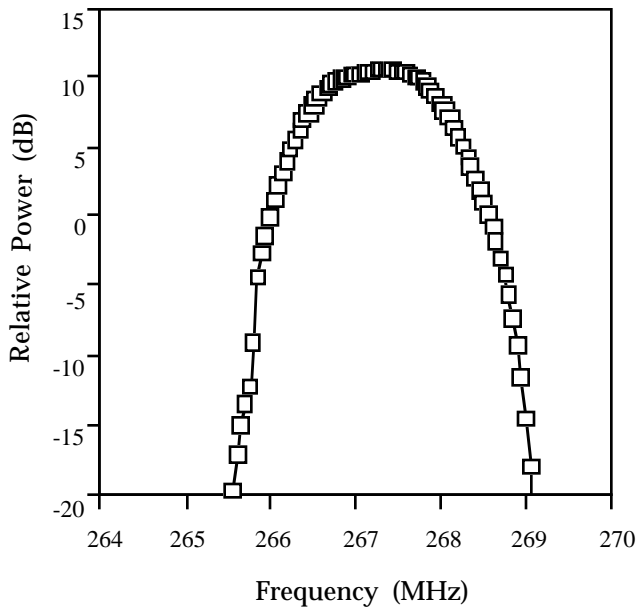

Figure 5: Klystrode bandwidth.

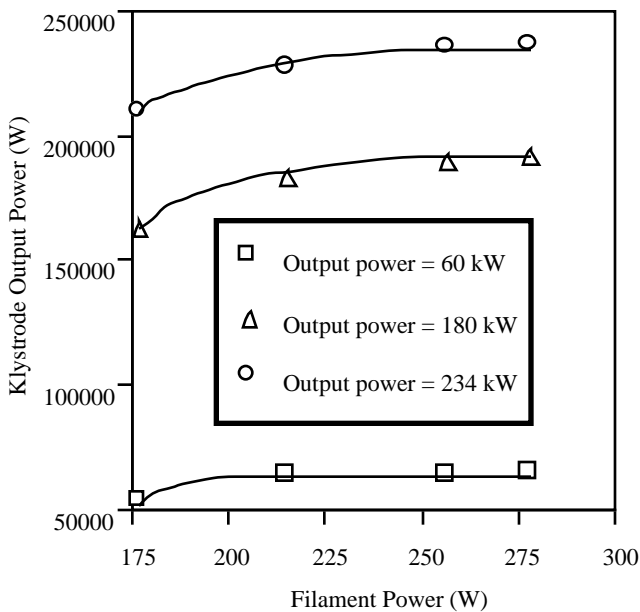

Figure 6: Klystrode output power vs. filament power for three output power levels.

The test results in Figure 6 were intended to quantify the level of filament heating. Inspection of the 180-kW and 234-kW curves shows that the knee is at approximately the same filament power level even though the beam current is different by 30%. This could lead to the conclusion that an appreciable amount of cathode heating is taking place, but more tests are necessary to further quantify this effect.

III. CONCLUSION

Because of its high efficiency, the variation of its efficiency with output power, and its linearity, we have demonstrated the klystrode to have performance

characteristics that are very appealing for accelerator RF systems. The relatively constant efficiency over a broad range of output power provides a control margin for accelerating cavity fields without the efficiency penalty that must be suffered with klystron amplifiers. The smoothly varying, monotonic phase characteristic of the klystrode is easily controllable, and the magnitude of the phase variation provides abundant phase margin for the other components of the system that contribute to phase variation (capacitor bank droop, beam effects, etc.). We believe that the klystrode has proved its viability as a high-power source at frequencies less than 300 MHz for output powers up to 250 kW CW. It is extremely attractive for CW service because of its high operating efficiency. The klystrode also appears to be a very attractive candidate for low-frequency superconducting accelerator applications that require reduced power levels.

At frequencies in excess of 1 GHz or for high-power, short-pulse service (>500 kW, <10% duty factor) where efficiency is not an issue, we believe the klystron to be the RF tube of choice. Its high gain and proven reliability will reduce total costs. It also tends to be higher perveance than the klystrode, decreasing high-voltage power supply cost.

We are concerned that at higher average power levels, the klystrode technology does not have an appreciable operating history on which to base reliability estimates. We have approximately 664 high-voltage hours on the 250-kW CW klystrode at Los Alamos, and we have had to process the grid at least three times to remove material deposited on the grid by the cathode. We are afraid that the cathode is being overheated by the RF drive power and that the result will be a reduced tube life.

IV. REFERENCES

- [1] Donald H. Preist and Merrald B. Shrader, "A high-power klystrode with potential for space applications," *IEEE Trans. Electron Devices*, vol. 38, no. 10, October 1991.
- [2] Donald H. Preist and Merrald B. Shrader, "The klystrode - an unusual transmitting tube with potential for UHF-TV," *Proc. IEEE*, vol. 70, no. 11, November 1982.
- [3] C. Loring, Jr. and M. Shrader, "The klystrode, a new high efficiency, high-power electron tube for UHF industrial applications," *J. Microw. Power Electromagn. Energy*, vol. 28, no. 3, 1993.
- [4] M. B. Shrader, D. H. Preist, and R. N. Tornoe, "The 267 MHz high-power CW klystrode amplifier," *Int. J. High Speed Electron. Syst.*, vol. 4, no. 4, 1993.
- [5] J. Y. Sheikh et al., "Operation of a high-power CW klystrode with the RFQ1 facility," *Proceedings of the 1993 IEEE Particle Accelerator Conference*, vol. 2, p. 1175.
- [6] M. Lynch, D. Keffeler, D. Rees, W. Roybal, "Installation and test results of a high-power, CW klystrode amplifier at Los Alamos National Laboratory," *Proceedings of the 1994 International Linac Conference*, vol. 1, p. 451.