

The CEBAF Fiber Optic Phase Reference System *

K. Crawford, S. Simrock, C. Hovater, A. Krycuk
Continuous Electron Beam Accelerator Facility
12000 Jefferson Avenue, Newport News, Va. 23606-1909 USA

Abstract:

The specified phase stability of the CEBAF RF distribution system is 2.9° rms per linac. Stability is achieved through the use of a temperature and pressure regulated coaxial drive line^[1]. The purpose of the fiber optic phase reference system is to monitor the relative phase at the beginning and ending of this drive line, between linacs, injector and separator to determine drift due to ambient temperature fluctuations. The system utilizes an Ortel 1310 nm single mode laser driving Sumitomo optical fiber to distribute a reference signal at 1497 MHz. The phase of this reference signal is compared to the 1427 MHz (LO) and the 70 MHz (IF) via a 360° phase detector. The detected information is then routed to the CEBAF control system for display with a specified resolution of $\pm 0.2^\circ$ over a 20° phase delta.

I. INTRODUCTION

The RF control modules for the CEBAF accelerator require that two frequencies, 70 MHz and 1427 MHz, be distributed throughout the accelerator site. This is accomplished in the linacs through the main drive line (MDL). The MDL for each linac consists of 750 ft of 1-5/8" rigid coax line for distribution of the 1427 MHz signal and 1/2" foam filled coax for the 70 MHz. Both lines are encased in a temperature regulated jacket. Proper operation of the multipass beam requires an energy spread of less than 2.5×10^{-5} . This places strict tolerances for the allowed slow phase error or drift. The main contributor to phase drifts is the temperature sensitivity of the 1-5/8" coax line ($6.5^\circ/\text{phase}/^\circ\text{C}$ @ 1427 MHz). In order to meet the phase stability specification it is required to regulate the temperature of the MDL to $\pm 0.1^\circ\text{C}$. In addition to temperature regulation, the 1-5/8" line is also pressurized and regulated to 4 psig to control any phase length changes due to ambient pressure variations. The purpose of the fiber optic phase reference system is to monitor the performance and provide an indication of the phase drifts of the injector, the MDL's of both linacs, and the separator.

II. SYSTEM DESCRIPTION

The fiber optic phase reference system consists of three main sub-systems. These are the laser diode, fiber optic cable distribution network, and the receiver chassis. The laser diode drives the 1497 MHz reference signal through the fiber optic cable distributed throughout the accelerator site. Optical couplers tap off a portion of this reference

signal and route it to receivers located in the injector, both linacs and separator building (Figure 1.). The receivers convert the optical signal into an electrical signal and mix it with 1427 MHz from the MDL. The resultant 70 MHz signal is then mixed with the 70 MHz MDL signal through two four quadrant multipliers configured as a quadrature detector. The phase is derived by a local DSP and passed to the control system through an RS-485 serial link. At present this information is displayed for the operators to make any phase adjustments manually.

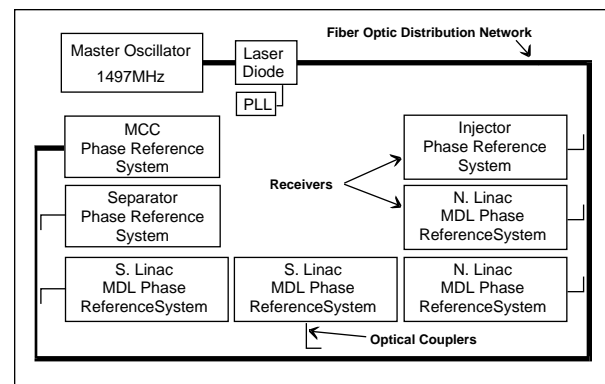

Fiber Optic Phase Reference System
Figure 1.

Laser Diode:

The laser diode is a single mode 1310 nm, 5 mW class IIIB laser (model 3540A) manufactured by the Ortel Corporation. The distributed feedback laser has a single mode optical line so that dispersive effects are virtually non-existent, allowing higher quality transmission over longer distances. The laser diode chassis incorporates a phase lock loop to maintain the phase within 0.2° . The laser is modulated with 1497 MHz from the master oscillator reference system in the machine control center (MCC).

Fiber Optic Cable Distribution Network:

The fiber optic cable used in this system has been developed by the Sumitomo Corporation and has been tested extensively at KEK and JPL^[2,3]. The cable provides a high level of phase stability with regard to temperature by manufacturing the cable such that the clad and the fiber have equal and opposite thermal drifts. To further reduce temperature effects on the fiber cable, the network has been distributed around the site in a 3 ft deep trench encapsulated in a concrete conduit. The fiber run, approximately 1.5 km around the site, exhibits a thermal shift of only 0.12° phase/ $^\circ\text{C}$. The network runs from the machine control center (MCC) to the injector, around the circumference of the accelerator, to the separator building and finally back to the MCC for a final phase comparison.

* Work supported by DOE contract DE-AC05-84ER40150

A combination of Gould and BT&D optical couplers are used to tap off portions of the optical reference signal. The couplers' values were chosen to allow a uniform power representation for each of the six sample points; this compensates for the attenuated signal levels as they are distributed through the 1.5 km of the fiber cable run.

Receiver Chassis:

The receiver is comprised of two main sub-systems. These are the 360° phase detector module (Figure 2.) and the DSP module (Figure 3.).

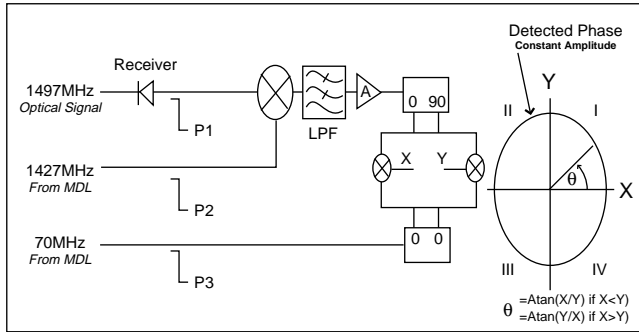

**360° Phase Detector
Figure 2.**

The 360° phase detector converts the 1497 MHz modulated laser reference from an optical to an electrical signal using a BT&D model PTD512 receiver diode. The converted signal is mixed with the 1427 MHz signal from the MDL creating a 70 MHz signal. The signal is then filtered to remove all higher frequency components and amplified. The other 70 MHz signal from the MDL is compared to the derived 70 MHz signal to provide phase information. The 360° phase detector is essentially what is known in industry as a quadrature detector and has been used successfully in the CEBAF RF control module^[4]. The derived 70 MHz signal is passed through a 90° hybrid power divider creating two orthogonal signals. The other signal is divided using a normal power divider. The four signals are then fed into two Analog Devices four quadrant multipliers (AD834) that develop the X and Y signals that determine the phase as shown in Figure 2. An important aspect of the design was the care taken to eliminate phase shifts due either to temperature, amplitude drifts, or radio frequency interference (RFI). The circuit is housed within an aluminum enclosure that has a water loop incorporated into it so that the box can be coupled to the CEBAF LCW system to maintain its temperature stability. All electrical components (amplifiers, multipliers) are operated at least 10 dB below their saturation points to keep amplitude modulation to phase modulation, “AM to PM”, effects low. The mixer is also operated 5 dB below its LO operation point for similar reasons. RFI shielding has been used extensively to keep out unwanted offsets that can produce errors in the quadrature circuit.

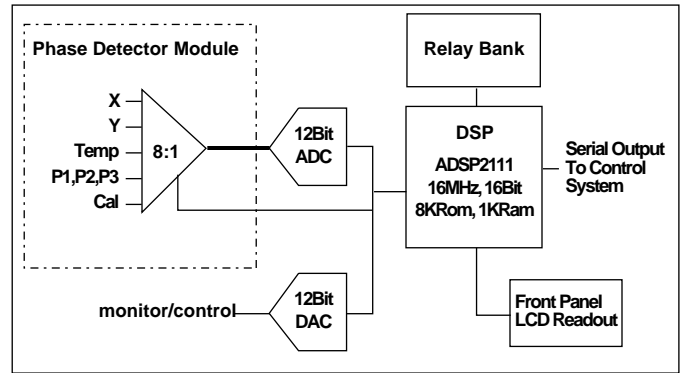

**Local DSP
Figure 3.**

The main purpose of the DSP module is to acquire the X and Y values of the detector, derive the phase, and deliver the information to the control system. The values acquired from the detector module are: power levels, X and Y voltages, module temperature, and offset values. The DSP used in this system is the ADSP2111 from Analog Devices. The 16 bit DSP reads all of the voltages through a 12 bit ADC providing 2.44 mV/bit with a ±5 V range. After tuning the quadrature detector gains, this allows for an ideal resolution of ±0.1°. The use of the local processor provides very fast acquisition of the phase signal to allow signal processing without burdening the control system. The ADSP2111 allows for 2 K program size to be stored in its internal RAM. Coupled with an 8 K EEPROM the processor can run four different programs (operating code, diagnostic code, algorithm code, etc.) or run one 8 K size program with attention placed on rebooting time. The DSP module also provides a local phase and temperature readout through a front panel LCD display. Control features have been incorporated into the system. These include a 12 bit DAC for future phase control/local analog readout and three programmable relays for system interface as well as a real time clock.

III. PERFORMANCE

In order to meet the 0.2° precision for a 20° phase delta, each of the 360° phase detectors requires three areas of attention. Both of the full quadrant multipliers have their input stages tuned to provide balanced maximum signal levels at all four inputs. Two sources, one slightly off frequency, are used to obtain the four quadrant circle. The X and Y components of the circle are acquired and fit to a perfect circle. Compensation coefficients to correct for phase skew, offsets and non-eccentricity are then obtained for use in correction code by the DSP. Finally the DSP routinely issues a calibration sequence to obtain the multiplier/amplifier chain offset values.

IV. CURRENT STATUS

Phase reference systems are installed in the injector and the north linac. They are presently undergoing beta testing. The system is being compared and calibrated against a path length measurement that measures the change in phase down and back of the main drive line. Typical diurnal main drive line drifts are approximately 10° to 20° . Results so far indicate that the laser reference system has some gain errors in the calculation of the MDL phase drifts. In addition to field testing, measurements on the receivers are being made to determine phase drifts due to temperature. Current schedule calls for all systems to be installed by June 1, 1995.

V. REFERENCES

- [1] Krycuk, A, Fugitt, J, Mahoney, K, Simrock, S, "The CEBAF Frequency Distribution System", Particle Accelerator Proceedings, 1991.
- [2] Tanaka, S., Murakami, Y., et al., "Precise Timing Signal Transmission by a New Fiber Optic Cable", KEK Report 90-5, May 1990.
- [3] Primas, L., Lutes, G., Syndor, R., "Stabilized Fiber Optic Frequency Distribution System", TDA Progress Report 42-97, vol. January-March 1989, Jet Propulsion Laboratory, Pasadena, California, pp. 88-97.
- [4] Hovater, C, Fugitt, J, "Analog Techniques in CEBAF's RF Control System", 1988 Linear Accelerator Conference Proceedings, pp. 412-414.