

RF Feedback Simulation Results for PEP-II*

R. Tighe, P. Corredoura, Stanford Linear Accelerator Center, Stanford University, Stanford, CA 94309 USA

Abstract

A model of the RF feedback system for PEP-II has been developed to provide time-domain simulation and frequency-domain analysis of the complete system. The model includes the longitudinal beam dynamics, cavity fundamental resonance, feedback loops, and the nonlinear klystron operating near saturation. Transients from an ion clearing gap and a reference phase modulation from the longitudinal feedback system are also studied. Growth rates are predicted and overall system stability examined.

I. Model Description

The development of a model of the PEP-II RF feedback system and longitudinal dynamics has been described previously[1]. The model has been in use predicting the overall stability of the High Energy Ring (HER) and the Low Energy Ring (LER) RF systems under heavy beam loading[2].

Feedback loops are included, as are the klystron, cavity, and longitudinal dynamics of 36 rigid macro bunches. Three feedback loops are required to stabilize the coupled-bunch oscillations that arise from the detuned cavity fundamental. A direct RF feedback loop, comb filter feedback, and a connection from the bunch-by-bunch longitudinal feedback are required. Signal from the longitudinal feedback is fed to the reference phase shifter to provide additional damping of the low order coupled-bunch modes[3]. Digital components of the feedback system are simulated using the actual system sample rates. Signal propagation delays in the system are also included. Figure 1 is a block diagram of the model.

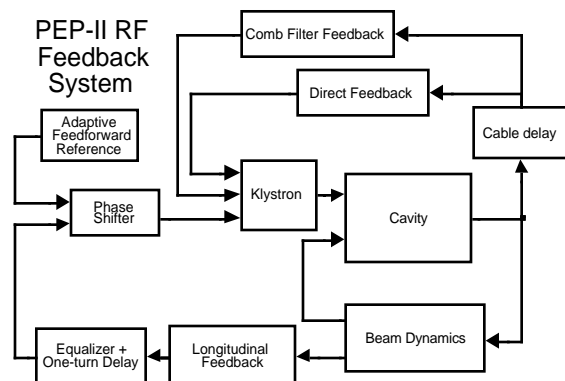

Fig. 1 System Block Diagram

All elements in the model have been discretized to a sample time of 25ns. This allows the model to run using difference equations for the system evolution and is faster than simulating continuous components which require an integration routine for solving. The model is written using MATLAB/Simulink[4] with some components written in C for greater execution speed. Analysis of the system in the frequency domain allows easy configuration, analysis, and optimization of the feedback loops.

II. Klystron Saturation and Bandwidth

An important aspect of the system is the requirement to run the RF stations near saturation to maximize operating efficiency. This leads to reduced AM gain through the klystron and degrades the performance of the RF feedback. Data taken from a typical tube provides a profile of the saturation curve for the klystron used in the simulation. For electrical efficiency it is desirable to run as far into saturation as possible; but not so far as to prevent sufficient amplitude modulation of the klystron power by the feedback system. The desired operating point was chosen to be at 90% of the saturated klystron power. Figure 2 shows the saturation curve used.

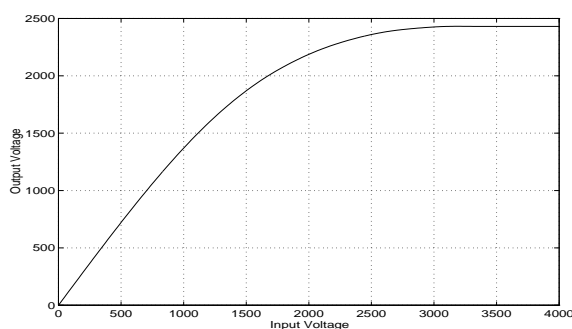

Figure 2. Klystron Saturation Curve

While considering the klystron specifications for use in PEP-II it became necessary to evaluate system stability with tubes of varied parameters. While it is optimal to maintain low group delay and high bandwidth for maximum feedback performance, they come at increased purchase cost. It is therefore important to predict the impact of klystron parameters on system behavior. Klystron bandwidth and delay were varied to quantify the effects on system stability. Table 1 shows simulation results for the LER with 3.15A for two types of tubes at varying levels of saturation. The last column refers to the

*Work supported by U.S. Department of Energy
Cont.tract DE-AC03-76SF00515

damping time of the slowest mode to damp. The table shows that at a higher current the effect of the klystron parameters on stability becomes apparent. It is clear that wider bandwidth and lower group delay are desirable and that the regime where this becomes important will be reached when currents are increased to raise luminosity.

Tube	stable?	Saturation	damping time
BW -3MHz delay- 150ns	YES	None	140 turns
	YES	81%	350 turns
	NO	85%	
BW -6MHz delay- 100ns	YES	None	120 turns
	YES	90%	750 turns

Table 1. Dependence on Klystron Parameters at 3.15A

III. Gap Transients

The HER is to have an ion clearing gap of approximately 5% of the ring circumference. The LER will have its gap partially filled in order to match the beam phase variations in the two rings, maintaining collisions at the interaction point. Figure 3 displays the cavity voltage and phase transients induced by the gap in the HER.

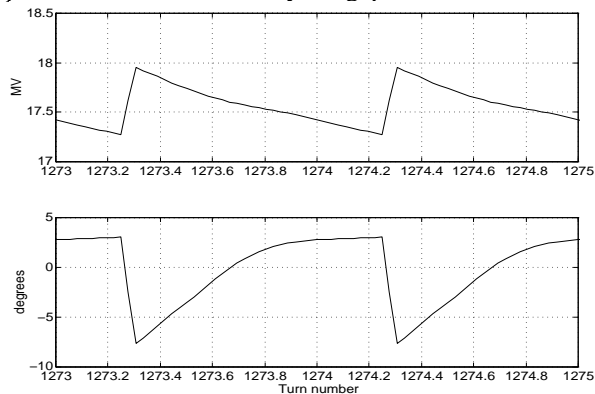

Figure 3. Cavity Voltage Transient

The model confirms the structure of calculated gap transients and allows evaluation of methods to accurately match the transients in the two rings[5].

Without accommodation for the gap transient the feedback would request more than the available power and the klystron would saturate. A procedure will be used to prevent the feedback system from attempting such a compensation.

IV. Feedforward algorithm

An adaptive algorithm has been devised to adjust the station RF reference to track the transient, keeping the klystron power constant. A profile corresponding to 20 MHz samples is generated by sampling the klystron drive over many turns, averaging and modifying the feedforward

values in order to produce a more constant klystron output. The feedforward signal is adapted slowly from turn to turn, and will not interfere with the operation of the feedback loops. Figure 4 shows the envelope of the forward power per cavity during the convergence of the algorithm. The convergence rate may be adjusted as needed.

Figure 5 shows the forward power variation per cavity over two turns both with and without the feedforward in effect. The power variation is reduced to approximately 0.5% with feedforward. Figure 6 shows the station reference signal generated by the feedforward system. This signal combines with the feedback signal to create a nearly constant reference for the klystron, maintaining low power fluctuation despite the gap. The feedforward algorithm will adapt during the filling of the ring and track as the current in the ring decays.

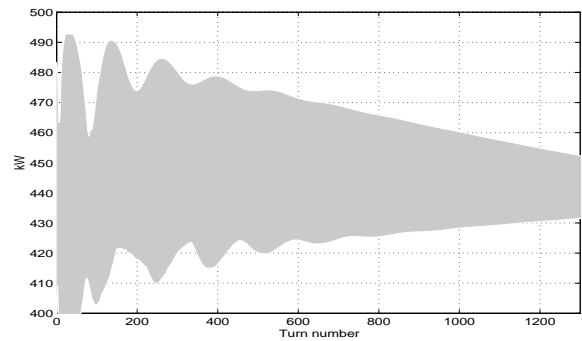

Figure 4. Forward Power Envelope During Adaption

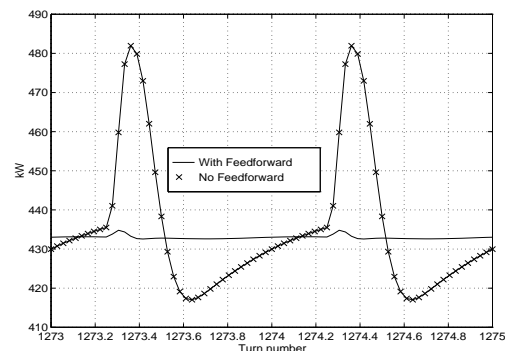

Figure 5. Forward Power Variation, with and without Feedforward.

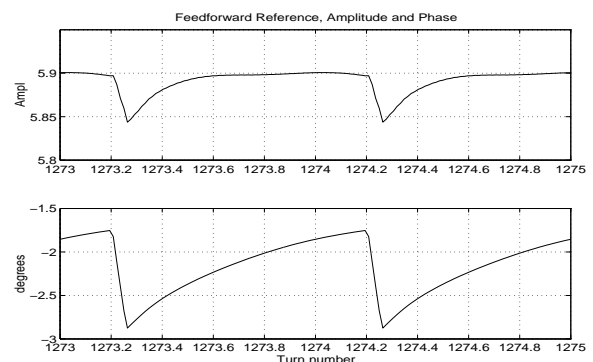

Figure 6. Feedforward Reference Signal

V. Simulation Results

The nominal operating configuration for the LER is to have three klystrons driving six cavities. Table 2 lists the relevant parameters for the nominal LER configuration.

Gap voltage	4.74 MV
Beam current	2.14 A
Synchrotron freq.	4.34 kHz
Detuning freq.	-155 kHz
Revolution freq.	136 kHz
Klystron power per station	2.8 MW
Energy loss per turn	0.87 MV
Momentum compaction	0.00122

Table 2. LER Parameters

Of the 36 bunches, 2 are filled with 60% of the nominal charge which is the typical gap transient matching approach. The maximum klystron power is set to be 10% above the operating point. Startup transients are minimized by calculating and configuring elements with values at or near their steady-state values where possible. Bunch offsets may then be set as desired. The planned injection scheme for the machine will produce small longitudinal disturbances. Figure 6 displays the modal response of the beam oscillations in the nominal LER configuration. All coupled-bunch modes are damped within 500 turns. The less heavily beam-loaded HER is stable as well, with faster damping.

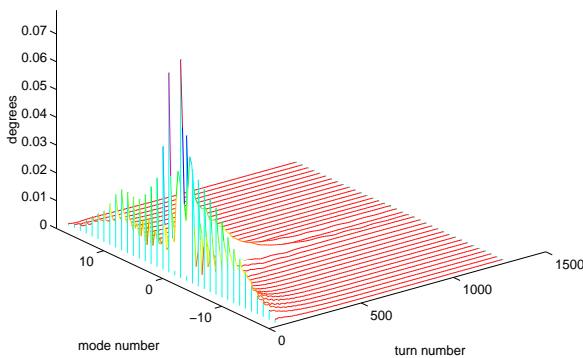

Figure 6. Modal Response of LER Simulation

V. Idle pair parking

Other studies involving the RF feedback system are possible. For example, in the event a ring is temporarily to run with one less than its normal complement of RF stations, that station's cavities must be parked on opposite

sides of the fundamental frequency. These cavities will be tuned such that they are centered between the second and third revolution harmonics to prevent unduly exciting coupled-bunch activity and minimize absorbed beam power. It is useful to examine the signals induced in these unpowered, parked cavities for use in monitoring them to minimize their contribution to the driving impedance. Methods of parked cavity resonant frequency monitoring have been examined using the model.

VI. Other Observations

The presence of the gap may lead to improved system stability due to the decoupling effect through tune spread on the coupled-bunch driving mechanisms. A configuration that is unstable without a gap can become a stable configuration when a gap is introduced. This effect has been observed in the simulation. The full extent of this raising of the stability limit requires further study.

VII. Conclusion

The model has been is use to test components and algorithms as well as to predict the PEP-II RF system behavior in the presence of nonlinearities. The ability to analyze the model in both the time and frequency domains is very powerful, allowing for straightforward configuration of the feedback loops. Both PEP-II rings with gaps and saturating klystrons have been shown to be stable using RF feedback techniques and feedforward compensation.

The model has also proved useful for klystron evaluation, feedforward algorithm testing, and gap transient matching. The model can be readily adapted to represent other storage ring RF systems.

VIII. REFERENCES

- [1] R. Tighe, "RF Feedback Simulation for the PEP-II B Factory", SLAC-PUB-6535, Proceedings of the 1993 Particle Accelerator Conference, pp. 1957-1959.
- [2] P. Corredoura, et al., "Low Level RF System Design for the PEP-II B Factory", these proceedings.
- [3] J.D. Fox, et al., "Feedback Control of Coupled-Bunch Instabilities", Proceedings of the 1993 Particle Accelerator Conference.
- [4] Matlab/Simulink, The Mathworks, Natick, MA 01760 USA
- [5] F. Pederson, "RF Cavity Feedback", B Factories - The State of the Art in Accelerators, Detectors, and Physics", SLAC-400,1992, pp. 192-207.