

THE LARGE HADRON COLLIDER VACUUM SYSTEM

B. Angerth, F. Bertinelli, J.-C. Brunet, R. Calder, F. Caspers, P. Cruikshank, J.-M. Dalin, O. Gröbner, N. Kos, A. Mathewson, A. Poncet, C. Reymermier, F. Ruggiero, T. Scholz, S. Sgobba and E. Wallén, CERN, AT Division, 1211 Geneva 23, Switzerland.

I. INTRODUCTION

The two rings of the LHC beam vacuum system have a total length of about 54 km of which almost 48 km will be at 1.9 K, the temperature of the superconducting magnets [1].

With the design energy of 7.0 TeV, combined with a bending radius of 2784.32 m, the critical energy of the synchrotron radiation emitted by the protons is 44.1 eV. At the maximum current of 536 mA each beam will emit a photon flux of $9.44 \cdot 10^{16}$ photons $s^{-1} m^{-1}$ and a power of $0.206 Wm^{-1}$.

The total synchrotron radiation power emitted by the two beams is $0.41 Wm^{-1}$ which, combined with an additional resistive wall power loss of $0.15 Wm^{-1}$ for both beam tubes, would be a considerable heat load for a 1.9 K cryogenic system. Thus a so-called beam screen, maintained at a temperature between 5 K and 20 K by gaseous helium flow, is inserted in the magnet cold bore to intercept this power.

The synchrotron radiation photons incident on the beam screen (or other) surface will desorb gases (H_2 , CH_4 , CO and CO_2) from the near surface (primary desorption); gas which then may be cryopumped back onto the very same surface. These physisorbed molecules, which are still exposed to the photons, are relatively loosely bound and easily re-desorbed and recycled by these photons (secondary desorption). In addition, more and more gas may build up on the surface of the screen until, when a monolayer or so is exceeded, the thermal vapour pressure of the H_2 component will increase rapidly to a level incompatible with the required beam-gas lifetime of 100 hours. This lifetime implies a H_2 gas density $\leq 9.8 \cdot 10^{14}$ molecules m^{-3} (i.e. $\leq 1.0 \cdot 10^{-9}$ Torr at 10 K), or correspondingly less for heavier gases (e.g. $\leq 7.1 \cdot 10^{13}$ molecules m^{-3} for CO_2).

The ion induced desorption yields from this condensed gas layer also increase with increasing quantity yet again progressively deteriorating the vacuum [2].

With bunched proton beams, pressure rises can also occur due to electron multipactoring driven by the electric field of the proton bunches [3].

In order to limit the pressure increase due to the above effects the beam screen will be perforated over a few percent of its surface to allow pumping by the 1.9 K cold bore surface, where the vapour pressure of all gases (except He) is negligible, and the condensed gas is shielded from synchrotron radiation, ion bombardment and multipactoring.

II. BEAM SCREEN

The present design of the beam screen is based on a 1 mm thick stainless steel tube, for mechanical strength, with a square cross-section and Cu coated on the inside. To minimize the beam coupling impedance of the screen the interior surface must have a high electrical conductivity and this is provided by the Cu which can be deposited either by electroplating [4] or in bulk form by an overlay process [5].

A thick bulk Cu screen would collapse due to the large electromagnetic forces induced during a magnet quench. It has been shown that a Cu layer 50 μm thick is sufficient from an impedance point of view and results in acceptable quench induced forces.

This square cross-section (compared to circular or elliptical sections) maximises the available horizontal and vertical apertures (44 mm x 44 mm) while, at the same time, leaving space between it and the surrounding 1.9 K cold bore for the supports and the cooling pipes (brazed or laser welded to the outside) which maintain the screen temperature between 5 K and 20 K. This is shown schematically in Figure 1.

To extract the synchrotron radiation and the resistive wall power loss in the screen one cooling pipe is enough, but two or even four may be installed for symmetry reasons to minimise magnetic field distortion.

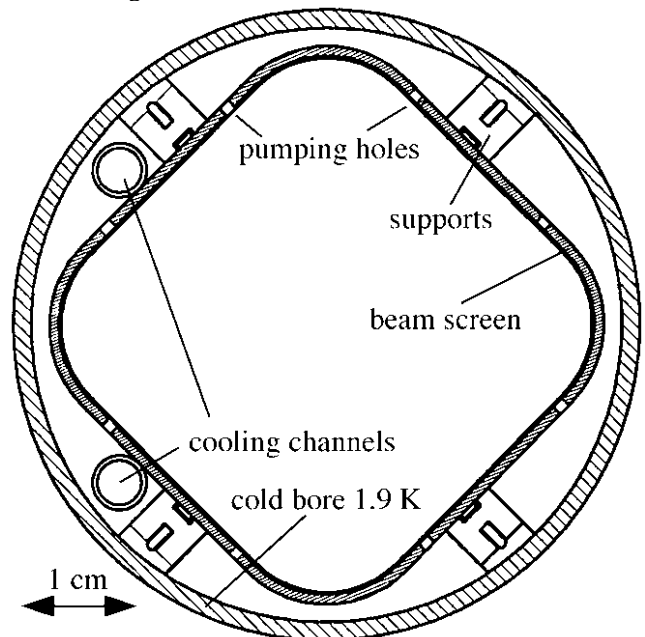

Figure 1. A schematic cross-section of the square section beam screen in the 1.9 K cold bore tube.

The supports are injection moulded polyetherimide (Ultem 2100, General Electric Plastics) which has a good radiation resistance and a low thermal conductivity.

The pumping holes in the beam screen represent discontinuities for the image currents of the beam and, compared to a non perforated screen, result in an increased beam coupling impedance. A particular effect that influences the real part of the impedance is that power may be coupled through the holes into the space between the beam screen and the vacuum chamber (this configuration forms a coaxial line or TEM line) and propagates nearly (due to the presence of the dielectric supports) in synchronism with the beam. The forward coupled signal gradually builds up in strength (coherently) until a certain equilibrium is reached and, leaking back into the beam screen, further adds to the real part of the coupling impedance. This effect depends on the size of the holes and the additional power loss is estimated to be about 0.01 W m^{-1} .

A suitable pumping hole shape which minimises the impedance is that of a narrow slot with rounded ends. In order to reduce as much as possible the contribution to the impedance from so-called trapped modes, the length and longitudinal position of the slots will be randomised [6].

This randomisation of the slot spacing helps to suppress higher frequency modes beyond waveguide cut-off associated with the slot periodicity. In particular, it reduces the forward and backward scattered power both within the beam screen and the backward coupled power into the TEM mode propagating between the screen and the cold bore.

The present design has 4.3% of the beam screen surface perforated by eight rows of lengthwise slots of width 1.5 mm and lengths varying randomly between 6 mm and 10 mm. This pattern will be repeated every 500 mm.

III. MAGNETIC PERMEABILITY

With the square section beam screen and its cooling pipes it has been shown that a magnetic permeability less than 1.005 (in the operating temperature range 5 K to 20 K) is necessary to avoid a significant magnetic field distortion [7]. Since the conventional 300 series stainless steels have permeabilities well in excess of 1.005 at low temperature, several other grades of stainless steel containing high concentrations of N₂ and Mn and giving acceptably low permeabilities are being evaluated for the construction of the beam screen. Taking into account the possible manufacturing steps, the weldability and the magnetic properties of the welds in these steels are also being investigated.

IV. VAPOUR PRESSURE

Between 5 K and 20 K the H₂ component of the cryopumped gas layer will have a vapour pressure which will increase rapidly when the coverage approaches one monolayer. Except for He, the vapour pressures of the other gases are negligible. Compared to pure H₂, the effect adding

other gases is to reduce substantially the vapour pressure of the H₂. This is illustrated in Figure 2 where the adsorption isotherms at 4.2 K have been measured in the laboratory and with no radiation for pure H₂ and for H₂ with various concentrations of CO₂ [8]. However, in reality the secondary recycling effects will probably remain and this suppression of the vapour pressure may not be a lasting effect in the LHC machine.

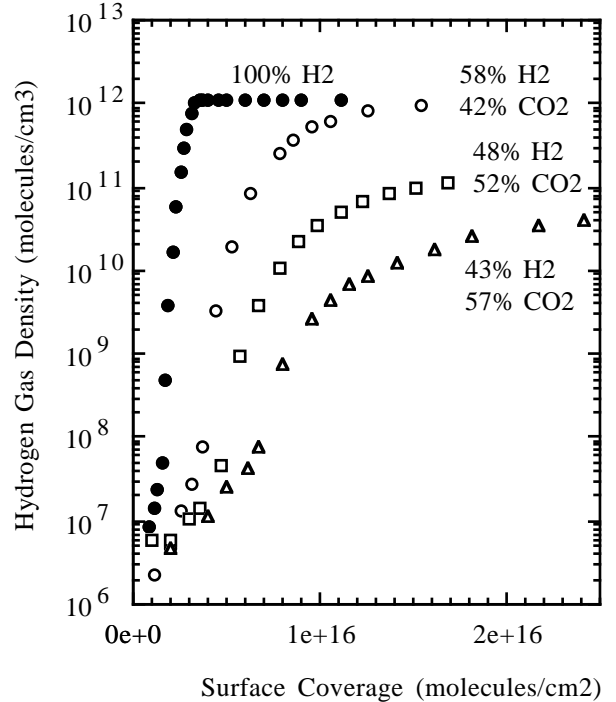

Figure 2. The H₂ vapour pressure of H₂/CO₂ mixtures condensed at 4.2 K as a function of surface coverage.

V. BEAM SCREEN VACUUM BEHAVIOUR

Assume that only H₂ is desorbed by the photons, and that the beam screen temperature is less than 20 K so that some H₂ will be cryopumped on to its inner surface.

At the start of the desorption an initial minimum gas density (pressure) in the beam screen will be determined by the total desorption rate and the cryopumping speed of the complete surface (including holes). As the surface becomes saturated, re-emission of H₂ causes the density to rise, possibly attaining a limiting density when there is no net pumping by the cold surface since all the desorbed gas will be taken by the pumping slots which are backed by a cryopump of infinite capacity. This limiting equilibrium gas density is now determined by the total desorption rate and the pumping speed of the slots. The pumping speed of the slots thus provides an upper limit to the gas density.

The ratio of this limit to the initial density is equal to the ratio of the pumping speed of the whole surface to that of the slots. For a sticking coefficient of 1 and 4.3% of the surface slotted this ratio is 23.3.

VI. PHOTON INDUCED GAS DESORPTION

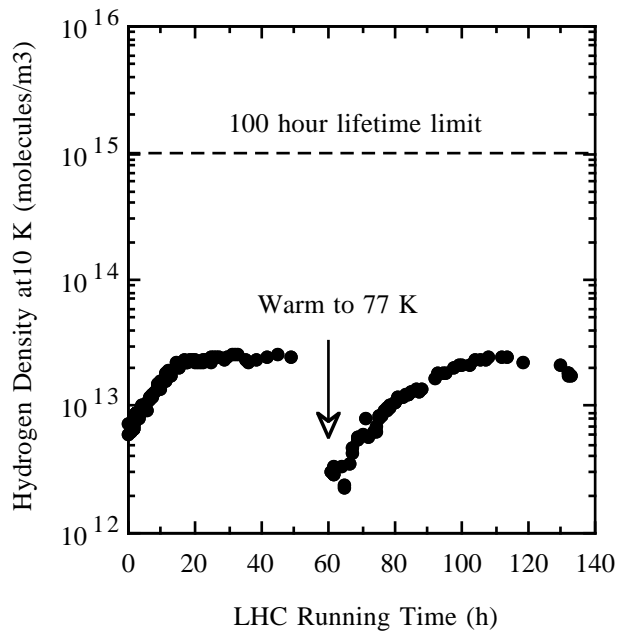

Figure 3. The H₂ gas density in the LHC as a function of the running time in hours with 53 mA and a 10 K beam screen with 2% slots.

The behaviour of vacuum chambers exposed to synchrotron radiation at room temperature is relatively well known in that the desorption yields and their variation with photon dose have been measured for a variety of chamber materials and critical energies [9]. However at room temperature all secondary effects such as recycling of adsorbed gas are negligible and, in order to try to quantify the low temperature behaviour, a collaboration was established with the Budker Institute for Nuclear Physics, Novosibirsk, Russia, to make the appropriate measurements.

The results are shown in Figure 3 where the data have been scaled to the LHC parameters at 7.0 TeV and 53 mA (i.e. the estimated initial operating current). Of necessity all the measuring instruments are at room temperature and the gas densities in the cold beam screens were calculated using the Knudsen relation. In this particular experiment only H₂ and some CO were detected. The measurements of the desorption yields at low temperature were carried out on 1 m long prototype beam screens in a specially designed cryostat installed in a dedicated synchrotron radiation beam line on the VEPP 2M electron-positron storage ring [10]. The nominal energy of the VEPP 2M storage ring is around 500 MeV but to reproduce the low critical energy of the LHC it was run at an energy of 300 MeV which corresponds to a critical energy of 50 eV, close to the 44.1 eV of the LHC.

The synchrotron radiation was incident on the side of the beam screen at a glancing angle of 10 mrad and illuminated almost the complete 1 m length of the beam screen. The screen was perforated with 10 mm x 1 mm longitudinal slots over 2% of its surface and maintained at 10 K with the surrounding cold bore at 3 K.

The data of Figure 3 show the initial H₂ density increase due to secondary effects followed by the limitation due to the pumping slots. The ratio of the limit density to the initial density is less than that calculated from the area of the slots and the beam screen indicating that the sticking coefficient is <1.

After warming to 77 K to desorb H₂, CH₄ and CO, a similar behaviour is observed with some evidence of a reduction in the desorption yield (cleaning) towards the end. The measured gas densities are well below that necessary for the 100 hour beam-gas lifetime limit. However it must be repeated that CO₂, which has a nuclear scattering cross-section about 13.9 times that of H₂, was not detected but may still be desorbed in the LHC beam screen and thus contribute the main beam-gas lifetime limitation.

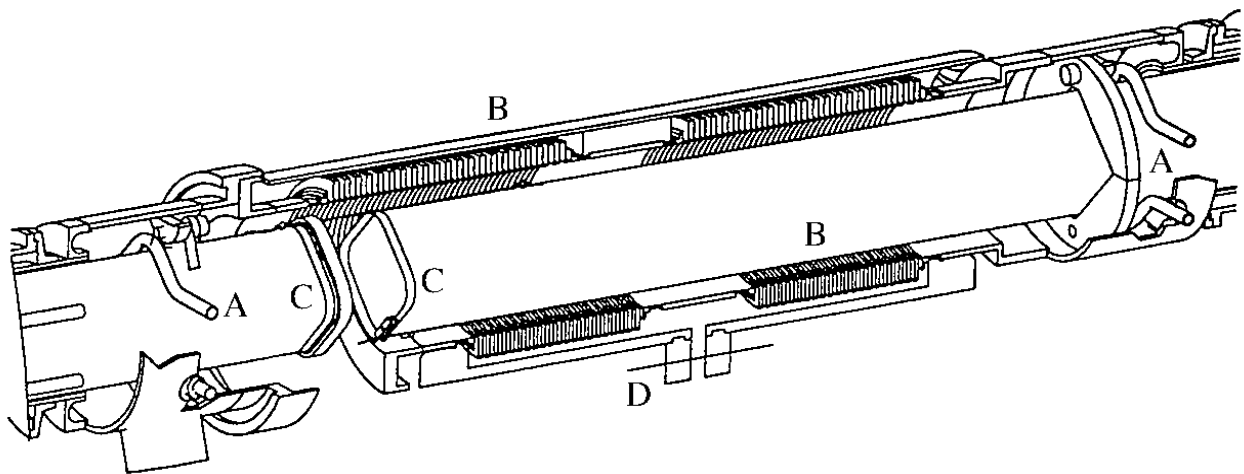

Figure 4. A schematic view of the intermagnet connection showing the beam screen cooling channels A and the bellows B. The lower part shows the bellows compressed for mounting using tool D and the upper part shows the assembled bellows. The open gap C between the beam screens is bridged by spring contacts (not shown).

VII. INTERMAGNET CONNECTION

A schematic diagram of the prototype intermagnet connection is shown in Figure 4. Each beam screen with its cooling pipes must be joined to the next between each magnet via flexible connections. For beam impedance reasons the transition must be smooth and able to absorb the 45 mm contraction of the magnet cold mass when it cools to 1.9 K. Thus there are a series of BeCu springs in good electrical contact with the beam screen to provide continuity for the image currents. Since there are at least 3000 intermagnet connections, each with 4 welds between vacuum and liquid He, it was decided as a matter of principle to try and avoid He to beam vacuum welds. As He will not be cryopumped, any leak may be critical for the operation of the LHC. The design, therefore, is such that the cooling pipes emerge into the insulation vacuum where all welds to the flexible connectors are made.

VIII. PRESSURE MEASUREMENT

The measurement of pressure or, to be more precise, gas density in the cold parts of the beam vacuum system has always been considered to be difficult since all conventional measuring instruments have been designed to operate at room temperature and also may dissipate a few Watts.

The obvious solution of simply taking one of the conventional hot filament vacuum gauges and mounting it on a test vacuum chamber and immersing all in liquid He at 4.2 K was tried and proved to be successful [11, 12] in that the gauge head worked and gave meaningful readings. However, this particular gauge head dissipated almost 2 W which was consequently absorbed by the He.

A second more elegant method of measuring the gas density in the LHC beam vacuum could consist in collecting the electron current produced by the beam ionisation of the residual gas on a system of biased electrodes placed at intervals around the ring [13]. The measured current is proportional to the average total gas density. For vacuum diagnostic purposes, an LHC proton beam would be debunched and the electron current measured around the machine. In addition to measuring the average residual gas density around the ring this method could be used to detect He leaks before they are able to be detected by the room temperature measuring devices placed at widely spaced intervals around the machine [14,15]. Similar diagnostics have previously been used routinely in the CERN Intersecting Storage Rings and Antiproton Accumulator.

IX. WARM SECTIONS

About 3 km (i.e. 10%) of the machine consists of vacuum chambers at ambient temperature. To reduce the coupling impedance the electrical conductivity of the vacuum chambers in the warm sections must be as high as possible and therefore

they must be made of either Al or Cu with a thickness of at least 1 mm.

In the warm sections a total pressure $< 1 \cdot 10^{-10}$ Torr containing 90% H_2 is required, the rest being CH_4 , CO and CO_2 . The chambers will therefore be baked.

An additional requirement is that, with beam, the vacuum does not exhibit any instabilities due to ion bombardment or electron multipactoring. The installed pumping speed and its distribution will therefore be such to give the required base pressure and vacuum stability. Also the vacuum chamber inside surface must have a low secondary electron yield to ensure no beam induced multipacting.

X. INSULATION VACUUM

In order to provide sufficient thermal insulation, the pressure in the insulation vacuum must be in the 10^{-6} Torr range. This may at first sight seem trivial but it must be remembered that there are many layers of thermal insulation which present a large thermal degassing load. During operation however, efficient pumping of all gases except He will be provided by the 1.9 K surface of the superconducting magnets.

During the first few weeks of running the LHC magnet string test with one quadrupole and two dipole magnets it was observed that the first pumpdown of the insulation vacuum from atmospheric pressure to $1 \cdot 10^{-2}$ Torr, where the turbomolecular pumps can be turned on and a He leak detection started, took about 30 hours. After a return to atmospheric pressure using dry N_2 , the second pumpdown to the same level took only about 14 hours.

The total pressure before cooldown was in the low 10^{-4} Torr range and consisted mainly of H_2O . After cooldown, the total pressure, measured with gauges at room temperature was in the low 10^{-6} Torr range and again consisted mainly of H_2O [16,17].

For ease of testing during the installation phase and to contain any He leaks the insulation vacuum will be isolated at regular intervals by vacuum barriers.

XI. CONCLUSIONS

A design for the beam screen has been made which satisfies the criteria of aperture and impedance. The magnetic permeability requirements at low temperature are severe and necessitate the use of special high N_2 and Mn content stainless steels.

The adsorption isotherms for mixtures of the gases desorbed by synchrotron radiation have been measured at 4.2 K and show that the H_2 vapour pressure component is suppressed.

Measurements of synchrotron radiation induced gas desorption at 10 K at the Budker Institute of Nuclear Physics confirmed the predicted vacuum behaviour of the beam screen where the slots limit the gas density increases. For an LHC beam current of 53 mA, which is the expected current during

the initial operation, the resulting H₂ gas density was well below that required for a 100 hour beam-gas lifetime. However, CO₂, which has a nuclear scattering cross-section about 13.9 times that of H₂, was not detected during these measurements but may still be desorbed and further reduce the lifetime.

A design has been made for the intermagnet connection which satisfies impedance criteria and ensures that there are no He to beam vacuum welds.

The warm sections of the machine must be made from either Al or Cu and baked to obtain the necessary low pressures. In addition, considerations of vacuum stability and beam induced multipactoring place constraints on the pumping system and the secondary electron yield of the inner surface of the vacuum chambers.

Initial experience gained with the magnet string test indicated that, with the magnets at 1.9 K, the insulation vacuum reached the low 10⁻⁶ Torr pressure range thus providing a good margin of safety for the thermal insulation.

XII. REFERENCES

- [1] The Large Hadron Collider Accelerator Project, CERN/AC/93-03(LHC), 8 November 1993.
- [2] V. V. Anashin, G. Derevyankin, V. G. Dudnikov, O. B. Malyshev, V. N. Osipov, C. L. Foester, F. M. Jacobsen, M. W. Ruckman, M. Strongin, R. Kersevan, I. L. Maslennikov, W. C. Turner and W. A. Lanford, *J. Vac. Sci. Technol. A* (12)4, 1663, Jul/Aug (1994).
- [3] O. Gröbner, Proc. Workshop on $p\bar{p}$ in the SPS, Geneva 1980, CERN Divisional Report SPS- $p\bar{p}$ -1, Geneva, p.130, (1980).
- [4] J. Cl. Puipe and W. Saxer, Werner Flühmann AG, Ringstrasse 9, Dübendorf 1, CH-8600, Switzerland, XV th Int. Conf. on High Energy Accelerators, Hamburg, Germany, July 20-24, 1992, Supercollider 4, Edited by J. Nonte, Plenum Press, New York, (1992).
- [5] Technical Materials, Inc., 5 Wellington Road, Lincoln, Rhode Island, USA.
- [6] S. Kurennoy, University of Maryland Internal Report, No. 95-10, (1995).
- [7] B. Angerth, F. Bertinelli, J.-C. Brunet, R. Calder, F. Caspers, O. Gröbner, A. G. Mathewson, A. Poncet, C. Reymermier, F. Ruggiero and R. Valbuena, Fourth European Particle Conference, (EPAC 94), London, UK, p 208, July (1994).
- [8] E. Wallén (private communication).
- [9] J. Gómez-Goñi, O. Gröbner and A. G. Mathewson, *J. Vac. Sci. Technol.*, A 12(4), Jul/Aug (1994).
- [10] V. V. Anashin, O. B. Malyshev, V. N. Osipov, I. L. Maslennikov and W. C. Turner, *J. Vac. Sci. Technol. A* (12)5, 2917, Sep/Oct (1994).
- [11] M. G. Rao and P. Kneisel, CEBAF Internal Report TN-91-0057, August (1991).
- [12] V. Baglin, A. Grillot and A. Mathewson, Vacuum Group Technical Note 95-01, January, 1995.
- [13] A. Poncet, MT Division Internal Note, MT/95-01, (ESH), LHC Note 316, March, (1995).
- [14] D. Edwards Jr. and P. Limon, *J. Vac. Sci. Technol.*, 15(3), 1186, (1978).
- [15] J. P. Hobson and K. M. Welch, Brookhaven National Laboratory Report, BNL-47434, AD/RHIC-111, August 1992.
- [16] G. Engelmann (private communication).
- [17] P. Cruikshank (private communication).