

# DESIGN OF THE BUTTON BEAM POSITION MONITOR FOR PEP-II\*

N. Kurita, D. Martin, S. Smith, C. Ng, M. Nordby, C. Perkins, Stanford Linear Accelerator Center, Stanford University, Stanford, CA 94309 USA

The beam position monitor (BPM) was designed to provide a robust UHV feedthru and a reliable electromagnetic sensor. Stringent resolution requirements at low beam currents, bunch parameters, along with mechanical and chamber requirements produced challenges in the electrical, thermal, and structural design of the BPM's. Numerical modeling and experimental analyses were used to optimize the design. The higher order modes (HOM's) and beam impedance were modeled using MAFIA. Measurements agreed with the calculated  $1 \Omega$  transfer impedance at the 952 MHz signal processing frequency, and the first two HOM's found in MAFIA. Tests and analysis both showed the button signal power approaching 40 W. Temperature and stress distributions were analyzed using this power loading with ANSYS. An electronic grade CuNi was selected for the BPM to reliably weld into the copper chambers. Pin seal and compressive joints were considered for the insulator vacuum seals. Both glassy ceramic-to-metal and ceramic-to-metal seals were evaluated.

## I. INTRODUCTION

The high current and high resolution of the PEP-II B-Factory require a novel design for Beam Position Monitor (BPM). The major design goals are to achieve the resolution and precision requirements, to handle high power due to the bunch and current requirements of the machine, to minimize large discontinuities and subsequent impedances developed from resonances or trapped modes and to serve as a reliable vacuum feedthru. The design represents a compromise between electrical performance and vacuum reliability. Numerical modeling with MAFIA and ANSYS were used to optimize the design for signal performance, impedance and structural reliability.

## II. REQUIREMENTS

The PEP-II HER stores 3000 mA of 9 GeV electrons [1]. The BPM's are located 14 inches from the downstream end of every quad chamber. The vacuum chambers are made from octagonal copper extrusion. The BPM's consist of four button-style pick-ups welded symmetrically on the chamber. The individual button pick-

ups are 3.5 cm apart to equalize the x and y position sensitivities.

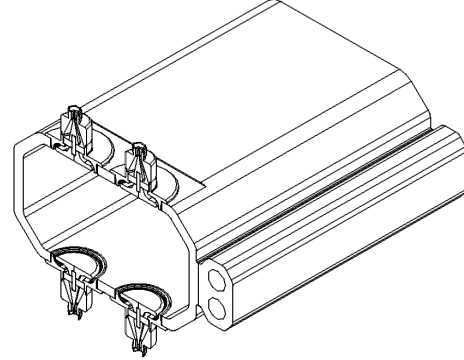

Figure 1: Downstream-End of Quadrupole Chamber.

The feedthru must be compatible with an ultra-high vacuum environment of  $3 \times 10^{-9}$  Torr. It needs to withstand 50 vacuum bakeouts at 200°C and 80,000 cycles from 15°C to 100°C. Vacuum failures occur from damaged or broken feedthrus due to their high profile and vulnerability. The current design addresses this problem by producing a low profile and well protected feedthru.

To meet the scientific needs the following resolution and precision requirements were defined (see table 1).

Parameter	Requirements
Resolution @ Current	15 $\mu\text{m}$ @ $1 \times 10^{10}$ e-, averaged over a 1000 turns. 1mm @ $5 \times 10^8$ e-, single bunch, single turn
Accuracy of measured beam position with respect to quad magnetic center	$\pm 1\text{mm}$ $\sigma < 0.5 \text{ mm}$ single bunch, single turn
Dynamic range, (position)	Meet the above resolution and accuracy spec. for (x,y) within 1 cm of center.
Mechanical Accuracy	0.38 mm
Electrical Accuracy	0.38 mm

Table 1: Operational Requirements

\* Work supported by US Department of Energy, contract number DE-AC03-76F00515. Presented at the US Particle Accelerator Conference and International Conference on High-Energy Accelerators (PAC95), Dallas TX, USA, May 1995

### III. BPM DESIGN DETAILS

#### *Button and Center Conductor*

The BPM's consist of four button style UHV feedthrus. The buttons are 1.5 cm in diameter to provide 1 mm of position resolution at  $5 \times 10^8$  e<sup>-</sup>. The button is brazed to a molybdenum center conductor. The diameter was optimized using MAFIA to increase sensitivity and decrease the Q of trapped modes[2]. The gap between the button and the housing is 1 mm to minimize the HOM effects without adding excessive capacitance.

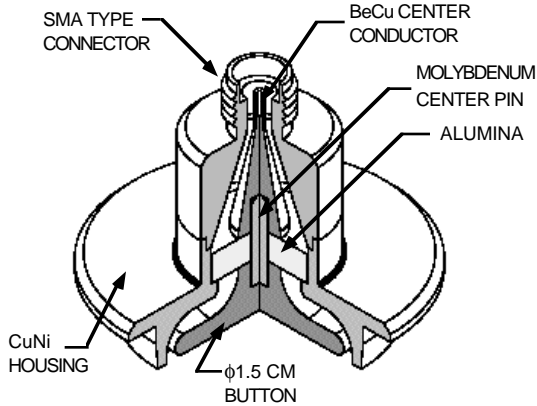

Figure 2: Cut away of a button pick-up

#### *Vacuum Seal-Dielectric Material*

The dielectric material most commonly used in BPM's is alumina. SLAC is requiring a minimum of 98% alumina for its thermal conductivity. Previous designs at SLAC and other accelerators typically use a compressive T joint for the ceramic-to-metal seal. However, this type of seal has many discontinuities which can adversely affect the electrical performance or create trapped modes. The current design uses a pin seal joint keeping the discontinuities to a minimum. The pin seal produces an outer diameter compression seal due to the mismatch of thermal expansion coefficients of the materials. The pin seal joint is not as robust as the compressive T joint, but has been proven in other accelerators to have sufficient strength to handle the vacuum load and thermal stresses.

Alumina borosilicate glass or "glassy ceramic" has been shown to be an acceptable alternative dielectric material. The glassy ceramic is an alumina strengthened glass and has a lower dielectric constant. This improves the electrical performance by decreasing the impedance mismatch. The design also eliminates brazing and simplifies the manufacturing process. The vacuum seals are a compressive pin seal between the metal housing and the glassy ceramic and a chemical bond between the glassy ceramic and the molybdenum pin. The major disadvantage is the minimum exposure glassy ceramic BPM's have had in the accelerator environment; however, some have been

operating in positron accumulator at Argonne National Laboratory for about half a year [3].

#### *Vacuum Seal-Welding Feedthru to Quad Chamber*

The pick-ups are electron beam (EB) welded into the chamber. This reduces the overall profile of the feedthru, decreases manufacturing tolerances, and fits easily into the chamber space. An electron beam weld minimizes the heat affected zone and increases the control and accuracy of the weld. Several materials were investigated for permeability, mechanical strength, welding and vacuum compatibility. Electronic grade 70/30 "cupronickel" was found to fit all of the requirements.

Copper and nickel are mutually soluble in each other, therefore, copper and cupronickel should produce a reliable weld. Several EB weld tests were performed. No adverse effects from the alloying were found, even during mixing and rewelding of the joint. The permeability of the weld did not increase from its unalloyed state. Welds were subjected to thermal shock tests by elevation of temperature to 250°C followed by immersion into liquid nitrogen. No leaks were observed.

In case of BPM failure, the weld joint of a BPM needs to be removed without contaminating the vacuum chamber. A test of this process was performed by a grinding process and a new BPM mock-up was successfully re-welded to the chamber. The BPM's will be replaced in a clean room.

#### *BPM Cover*

To decrease the possibility of failure the BPM's will be protected by a box attached to the BPM support. The cables will also be strain relieved to this box and the raft.

#### *Positional Alignment and Calibration*

The quad chamber is mounted directly to the quad magnet at the BPM. Therefore, the chamber and the BPM's move with the quad magnet which reduces inaccuracies due to thermal motion. The 25 μm motion is primarily due to thermal heating for 100% to 80% beam power causing thermal expansion of the support at the BPM and the bowing of the quad chamber.

Calibration of the BPM's electrical centerline with respect to the mechanical centerline will be performed in the lab using a rod technique and its location with respect to the magnetic centerline will be measured in the tunnel.

## IV. NUMERICAL AND EXPERIMENTAL RESULTS

Numerical and experimental data were obtained for electrical, thermal and structural performance. Also, the

transfer impedance of the BPM's was measured experimentally and calculated using MAFIA.

### *Electrical Measurement and Modeling*

A prototype of a 2 cm button was fabricated and electrically tested. The measurements were compared to results from circuit models of three types: lumped capacitance, stripline loaded at center, and radial transmission line and MAFIA.

The button was modeled as a center-tapped strip transmission line of length  $l$ , width  $wl$ , velocity  $c$ , and impedance  $Z_0$ . The load resistance is  $Z_L$ . The transfer impedance of this square "button" is given by Eqn. 1,

$$|Z_T(\omega)| = \frac{2gZ_L \sin(\omega l / 2c)}{\sqrt{\cos^2(\omega l / 2c) + (2Z_L / Z_0)^2 \sin^2(\omega l / 2c)}} \quad (1)$$

where  $g$  is the transverse geometry factor. A 2 cm button in the HER vacuum chamber has a  $1\Omega$  transfer impedance at the 952 MHz operating frequency. At full beam current of  $10^{11}$ e/bunch, with a 1 cm radial position offset, the nearest button will deliver some 40 W of broadband power. Using  $Z_T = 1\Omega$ , Eqn. 2 relates the load current in the  $50\Omega$  button termination to the beam current,

$$I_L / I_b = Z_T / Z_L \cong 0.02 \quad (2)$$

and agrees nearly exactly with the -34 dB (952 MHz) bench measurement.

The button possesses significant non-TEM resonances, which appeared in the solution of Maxwell's equations, and the MAFIA simulations. The lowest frequency HOM's are the TE modes when circumferential variations are allowed. The  $TE_{11}$  mode occurs at the frequency  $f \cong c/2\pi r_0$ , calculated at 4.7 GHz. This mode is cutoff in the small diameter output coaxial cable, and is therefore a high-Q resonance. In measurement this was easily observed at 5.73 GHz with a loaded  $Q = 21$ . Higher TE modes were also clearly present. These modes are strongly driven by the beam, dominating the beam impedance. However, they can be suppressed by introducing asymmetric features into the button. An extreme measure of short circuiting a point on the button circumference decreased the TEM power at 952 MHz by 1 dB, while increasing the total broadband power delivered to the load. Reduction of the button diameter to the present 1.5 cm brought its impedance within the machine's stability requirement.

### *Thermal/Structural Loading*

There are two areas of concern for the thermal stability of the BPM. First, the thermal stability of the feedthru is essential to meet the precision requirements. Second, the resolution requirements at low current results in high power

transfer at full current. As much as 40W delivered out the cable in the TEM mode has been estimated. MAFIA and numerical analysis estimated that 0.16 W is dissipated into concentrated areas of the alumina and 6 W at the interface between the center conductor and the alumina. An additional heat source of  $0.25 \text{ W/cm}^2$  was calculated using EGS and FLUKA for scattered SR on the button face. Thermal analysis using ANSYS was performed to determine the temperature distribution in the feedthru. A 3-D analysis verified that the concentrated heat loads in the alumina were negligible and that the primary heat load was at the interface of the center conductor and the alumina. A maximum temperature of  $110^\circ\text{C}$  was found on the button.

Thermal stresses were also calculated using ANSYS. Evaluation of the stresses due to heating of the pick-up showed that residual stresses in the compressive seal were needed to maintain a relative margin of safety. An estimate of the residual stresses was calculated assuming all parts are stress free at the softening temperature of cupronickel. Further analysis on power dissipation into the center conductor showed initial values were conservative.

## V. CONCLUSIONS

The SLAC button feedthru has been designed to meet the demanding vacuum, reliability and impedance requirements of the PEP-II project. The design was extensively modeled to reveal expected temperature, stress and impedance performance. Trade studies involving material selection, button size, connector type and transition geometry were conducted. Prototypes were fabricated which validated the analyses.

## VI. FUTURE WORK

At this time the pre-production order has been placed with several vendors. The feedthrus will be subjected to mechanical and electrical tests. Numerical and experimental analyses on their sensitivity and transfer impedance will also be performed. The production order will be based on a pass-fail evaluation.

## VII. REFERENCES

- [1] C. Perkins, et al, "Vacuum System Design for the PEP-II B Factory High Energy Ring", EPAC94 Conference Proceedings, London, World Scientific.
- [2] C-K Ng, et al, "Simulation of PEP-II Beam Position Monitors", these proceedings.
- [3] Personal communication with Dr. Bill Selyey of Argonne National Laboratory.