

Bellows Design for the PEP-II High Energy Ring Arc Chambers*

M. E. Nordby, N. Kurita, C-K. Ng, Stanford Linear Accelerator Center, Stanford University, Stanford, CA 94309 USA

An overview of the current bellows module design and performance parameters is presented. Performance requirements based on external chamber design constraints, and operational needs are discussed. Parameters include beam impedance of the RF shield, and electrical resistance of the shield gap joint. Also discussed is the analysis of the high-current thermal management, and structural and cyclic behavior of the bellows and RF shield. Experiments of the tribology and electrical resistance of the shield sliding joint are summarized, and their results presented. Existing and new design options are discussed in light of the analyses and experiments. The final design is presented as the optimal compromise between the varying parameters.

I. ARC CELL DESIGN INTRODUCTION

The PEP-II High Energy Ring (HER) is 2.2 km and stores 3000 mA of 9 GeV electrons[1]. The HER is hexagonal, with six arc regions containing 16 cells, each 15.2 m long. A cell consists of two dipole magnets, separated by a quadrupole/sextupole doublet. Figure 1 shows a typical half-cell:

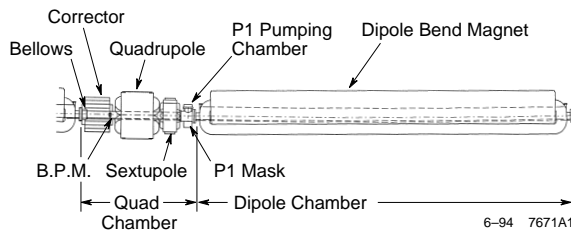

Figure 1: Plan View of a HER Arc Half-Cell

The arc vacuum chambers are made from octagonal copper extrusions. The octagonal shape fits the magnet gaps, yet maximizes the conductance for the 10 nTorr vacuum system[2]. Copper is chosen for its high thermal conductivity radiation absorption length and to minimize the gas desorption.

The chambers are supported at three places. The Quad Chamber is mounted to the quad magnet next to the Beam Position Monitor (BPM). This minimizes monitoring inaccuracies due to thermal motion of the BPM. Flex Supports hold both ends of the Dipole Chamber, allowing for thermal expansion along the beamline, but preventing any lateral motion.

II. BELLOWS MODULE DESIGN

The Bellows Module bridges the gap between the fixed end of the Quad Chamber at the BPM, and the end of the Dipole Chamber. It serves four discrete functions in the HER Arcs.

Thermal Motion

The Bellows Module accommodates the thermal expansion of a half-cell. The copper chambers expand 6.5 mm as they heat to their nominal operating temperature of 70°C, and 19 mm during the 150°C *in-situ* bake out.

Installation

The Module serves as the capstone of the half-cell: it is the last piece to be installed, and the first removed. The Module compresses 19 mm to allow installation. An additional 6.3 mm of stroke is needed for chamber alignments and fabrication tolerances.

RF Continuity

To minimize instabilities and impedances the Module must present a continuous chamber geometry and electrical conduction path. This is accomplished by 0.2 mm thick GlidCop® [3] Shield Fingers which bridge the gap between the neighboring chambers inside the convoluted bellows.

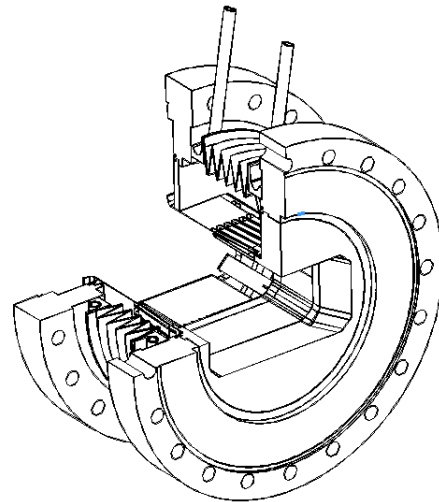

Figure 2: Bellows Module, Cut Away

The Shield Fingers cannot withstand the direct SR strike and are shadowed by a 5 mm offset between the neighboring chambers. To prevent an annular cavity which can produce trapped modes, the offset stub tapers inward.

* Work supported by US Department of Energy, contract number DE-AC03-76F00515. Presented at the US Particle Accelerator Conference and International Conference on High-Energy Accelerators (PAC95), Dallas TX, USA, May 1995

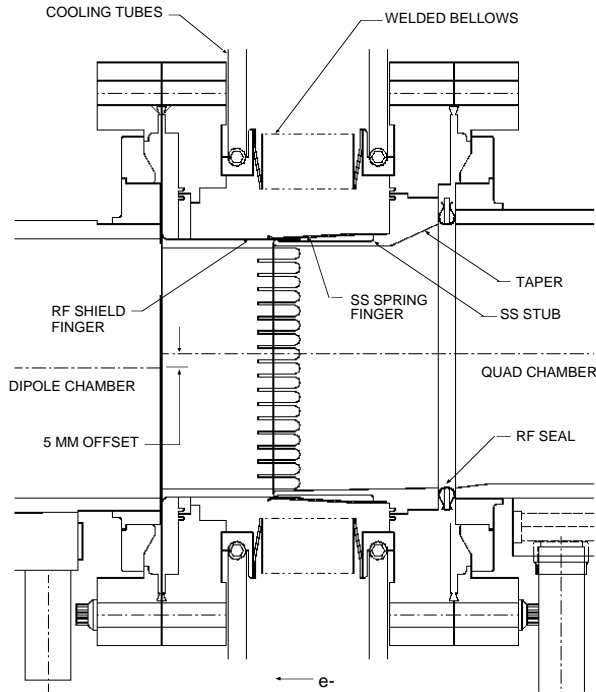

Figure 3: Plan View Cross-Section of Bellows Module

The fingers slide on the outside of a 2 mm thick stainless steel stub. The contacts between the stub and each of the Shield Fingers are ensured by external stainless steel spring fingers. For every shield finger there is a mating spring finger that exerts 170 grams of contact force. This minimizes the possibility of arcing across the joint, due to high *in vacuo* contact resistance.

The individual Spring Fingers apply a uniform contact load on all Shield Fingers around the octagon. Girdling springs, common in other designs, require a round or oval transition to ensure uniform loading on all fingers, and to prevent stress concentrations in the spring. Such a transition would produce a longitudinal impedance ten times higher than the octagonal Module [5], and increase the possibility of trapping higher-order modes.

The current Shield/Spring Finger design also reduces the likelihood of a finger losing contact which would produce a small cavity. Since the Spring Finger always applies force only at the contact point, the Shield Finger can never lift off that point, and can never touch anywhere else on the stub.

Cooling

All surfaces which are exposed to the beam passage are subjected to various sources of heat. Adequate conduction paths and cooling tubes brazed to the flanges ensure that they remain cool.

THERMAL LOADING

Although the Shield Fingers and stub are shadowed from the direct SR fan by the chamber offset, the module is

heated in varying amounts by four distinct sources which are described below.

Scattered SR

Calculations using EGS and FLUKA show that 10% of the power from the direct SR strike fan is re-emitted as photons and low-energy electrons. Near the Bellows Module, the power of the direct SR strike fan is 1170 W/cm². The shadowed Shield Fingers could intercept a heat flux of 0.25 W/cm² scattered around the 24.1 cm perimeter of the octagon.

Ohmic Losses

The image current traveling in the first few microns of the vacuum chamber wall produces heat due to the resistance of the wall material. In the Bellows Module, the stainless steel stub and the Shield Fingers are plated with 0.5 mils of copper and silver, respectively. The image current will travel solely through the high-conductivity plating and deposit less than 0.04 W/cm² of power.

Higher Order Mode (HOM) Heating

Analysis shows that the slots in the Shield Fingers at the corners of the octagon radiate approximately 0.45 W per Bellow Module due to the field of a TM HOM [6]. This power is primarily transferred to the Bellows Module convolutions. The inner surfaces that “see” the beam intercept 7 W (~0.07 W/cm²) of radiated power from secondary HOM’s.

Contact Resistance Heating

Large image currents and resistance at the sliding contact joint between the Shield Fingers and the Stub produce localized heating. Experimental data shows that this localized heating can cause a decrease in material strength followed by a reduction in contact force. This could lead to run-away heating at the contact joint. To decrease this possibility, the temperature of the contact joint must be kept to a minimum.

Thermal Analysis

The total heat load from these sources could deposit 0.36 W/cm² of combined power on the Shield Fingers. This produces a temperature at the tip of the GlidCop fingers of:

$$T_{TIP} = T_{BASE} + \frac{QL^2}{2kt}$$

Where the finger dimensions are: w = 4 mm wide, t = 0.2 mm thick, and L = 2.16 cm long. Cooling on the adjoining flange will keep the base of the Shield Fingers at 65 °C, so with a thermal conductivity, k = 3.65 W/cm-°C, the tip temperature could reach 91° based on 0.5 W/cm² of heat flux. This is far below the stress-relaxation temperature of AL-15 GlidCop, which is approximately 300°C [3]. GlidCop was chosen for its high thermal

conductivity in comparison to other types of strengthened copper. GlidCop's thermal conductivity is a factor of two higher than BeCu which is commonly used for Shield Fingers. Therefore, the local temperature at the tip will be higher in the BeCu. Also, BeCu over-ages and loses strength at 250°C for high strength BeCu and 455°C for high conductivity BeCu.

The effects of the high tip temperature are further minimized by the independent stainless steel Spring Fingers. These isolate the high-temperature region at the ends of the Shield Fingers from the high-stress area at the root of the Spring Fingers. Thus, if the Shield Fingers get hotter than expected, they are less likely to soften and fall away from the contact joint.

STRUCTURAL LOADING

Despite the high tip temperature, stresses in the Shield and Spring Fingers are produced primarily by the contact force at the sliding joint, and by the offset across the Module due to alignment and fabrication tolerances.

The 0.65 mm thick Spring Fingers provide contact force, so they see 205 MPa bending at their base. This is not affected by offsets across the Bellows Module because they are mounted solely to the stub.

However, the thin Shield Fingers are stressed only by offsets across the Module. The chamber Flex Support system allows up to 2 mm lateral offset, which produces a 90 Mpa stress at the root of the Shield Fingers. This bending stress does not significantly affect the contact force because the Spring Fingers are 15 times stiffer.

MANUFACTURING ISSUES

Two materials manufacturing issues have been significant factors in the design of the Bellows Module.

Sliding Joint Tribology

First, the tribology of the sliding joint *in vacuo* is a concern for three reasons: 1) overheating or galling at the contact joint could cold-weld a finger to the stub. This would destroy the finger. 2) Insufficient or excessive lubricity from silver-plating could produce silver dust by fretting at the sliding joint. This dust could enter the beam passage and possibly affect the beam lifetime and stability. 3) Plated surfaces could behave below expectations during operation, when high temperatures and high shear stresses could cause it to flake off.

Research and testing at SLAC have shown that a combination of 0.4-0.5 mils silver plating on the Shield Fingers, and 0.2-0.3 mils rhodium plating on the stub produce a good sliding joint. With the 170 gram force expected at the contact joint, tests have shown that the silver plating is thick enough to endure over 200,000 cycles at 200 °C. Thinner plating resulted in complete erosion the plating.

The rhodium plating on the stub is likewise an optimal thickness. Shear stresses in thicker plating reduce quality and adhesion, while thinner plating will not contain the image current traveling along the chambers.

Shield Finger Brazing

The second manufacturing issue is brazing. Our initial design, and that of most other bellows modules, used BeCu fingers. However, to attain the highest possible yield strength, these must be precipitation-hardened after being brazed to their retaining plate. Without this, the fingers cannot tolerate even moderate stresses without yielding.

To avoid this failure mode, GlidCop AL-15 was chosen as an alternative. This is a dispersion-strengthened copper, which does not require heat-treating, and does not overage. At room temperature, its yield strength is 380 Mpa, with 16% elongation. Experiments show only a 25% decrease in yield strength at the brazing temperature [3].

One of GlidCop's drawbacks is its lack of ductility. This makes it harder to form, and susceptible to fracture if strained plastically. However, manufacturing tests show that these problems can be avoided by smooth forming dies and large bending radii.

FUTURE WORK

Design and production efforts are focused in two directions. First, confirmation testing of the final sliding joint configuration is pending.

Second, a full prototype of the entire Bellows Module is now being prepared. This will prove out the complex fabrication and assembly techniques, and show areas where cost savings can be recognized.

REFERENCES

- [1] M. Zisman, ed., "PEP-II: An Asymmetric B Factory: Conceptual Design Report", SLAC Report 418, 1993.
- [2] C. Perkins, et al, "Vacuum System Design for the PEP-II B Factory High Energy Ring", EPAC94 Conference Proceedings, London, World Scientific.
- [3] GlidCop is a dispersion-strengthened copper alloy made by SCM Metal Products, Inc., Research Triangle Park, North Carolina, USA
- [4] S. Heifets, *et al*, "Impedance Study for PEP-II B-Factory", PEP-II AP Note No 99.
- [5] *ibid*.
- [6] S. Heifets, *op cit*.