

TRANSMUTATION AND ENERGY PRODUCTION WITH HIGH POWER ACCELERATORS*

G. P. Lawrence, Los Alamos National Laboratory, Los Alamos, NM 87545 USA

Accelerator-driven transmutation offers attractive new solutions to complex nuclear problems. This paper outlines the basics of the technology, summarizes the key application areas, and discusses designs of and performance issues for the high-power proton accelerators that are required.

I. INTRODUCTION

Stimulated by advances in spallation neutron sources, several groups worldwide are now evaluating the potential of accelerator-driven transmutation technology (ADTT) to provide new solutions to pressing nuclear problems [1,2]. Applications include destruction of nuclear waste (ATW), burnup of plutonium from weapons and spent reactor fuel (ABC), production of tritium (APT), and accelerator-driven fission-energy production (ADEP) using the Th²³²/U²³³ cycle. Several ADTT variants are being pursued, with technical details differing significantly. While the principal focus in this paper is on the set of concepts developed at Los Alamos, and on their associated accelerator requirements and design issues, some information on other ADTT approaches is provided to suggest the breadth of investigation.

ADTT concepts (except for APT) are based on a high-power proton beam driving a subcritical fissioning assembly through a spallation neutron source. APT is a special case in which thermalized spallation neutrons convert He³ or Li⁶ into tritium in a blanket that contains no fissile material; there is no neutron multiplication or power generation. Principal elements of an ADTT system are illustrated in the Los Alamos scheme shown in Fig.1. An 800-MeV linac delivers a high-

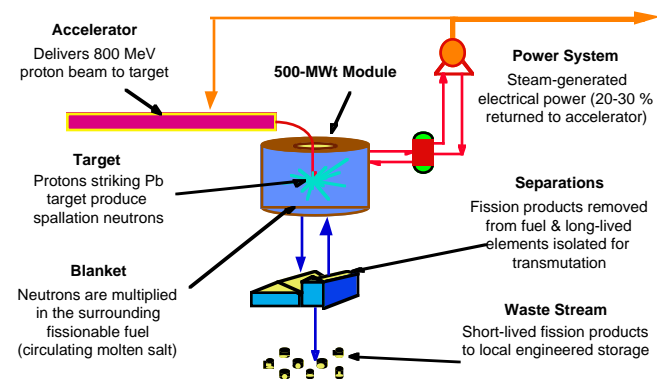

Fig. 1 General features of Los Alamos ADTT concepts.

current proton beam to a liquid Pb target, producing large numbers of spallation neutrons. These are thermalized and multiplied in a surrounding graphite-moderated blanket containing fissionable fuel and nuclear wastes in the form of circulating fluoride salts dissolved in a molten-salt carrier. Neutron multiplication in the blanket is typically in the range

10-20, which corresponds to a k_{eff} of 0.90 - 0.95, and power multiplication factors of 20 - 40. The energy produced in the high-temperature salt generates electricity with high efficiency (> 0.4); a fraction (20 - 30%) of the power is returned to the accelerator to produce the beam, with the balance available for export to the grid. Pu and other actinides in the blanket are burned to completion, while fission products are continuously removed from the circulating salt by physical, electrical, and chemical processing, and separated into long-lived and short lived isotopes. Long-lived products are returned to the blanket for transmutation, while short-lived fission products are sent to local engineered storage.

The advantage of accelerator-driven subcritical systems, in comparison with reactors is that they greatly broaden the design and operating space for the fissioning assemblies, in terms of safety and stability (fast shut-down and insensitivity to reactivity transients), superior neutron economy (extra neutrons for fission product burning), external neutrons (allowing deep burn with safe control margins), complete fuel utilization, and essentially total elimination of Pu.

II. ACCELERATOR REQUIREMENTS

Accelerator requirements for ADTT systems cover a broad range, from 400 - 1600 MeV proton energy, and 10 - 300 MW beam power. At the high end of the power range, only CW RF linacs currently provide realistic solutions. Present concepts are based on conventional (copper) accelerating structures, but the continuing development of superconducting RF (SRF) technology may in future provide cost advantages and technical attractions for some applications. At lower beam power levels, the competition is between pulsed conventional RF linacs, CW SRF linacs, high-current cyclotrons, and possibly induction linacs.

Critical relationships governing choice of beam energy and current for a given beam power requirement are the energy dependence of the spallation neutron production efficiency, and the accelerator electrical efficiency. Fig. 2 shows the calculated neutron efficiency for a stopping-length, tungsten target, plotted along with the number of spallation neutrons per proton. The former increases rapidly to a plateau beginning at about 1200 MeV, and then declines gradually at high energies as competing nuclear channels open up. For a fixed beam power in a conventional RF linac, the "wall-plug" to beam power efficiency declines with increasing energy. Because of the competing neutron-production and accelerator efficiencies, there is an optimum beam-energy band that yields the best overall plant efficiency. This band is broad and shifts to higher values as neutron requirements increase. Parameterized models based on these relations and incorporating key cost factors (per Watt of installed RF power, per meter of accelerating structure, etc.) are used to optimize ADTT system designs. In combination with beam physics constraints these

* Work supported by the US Department of Energy

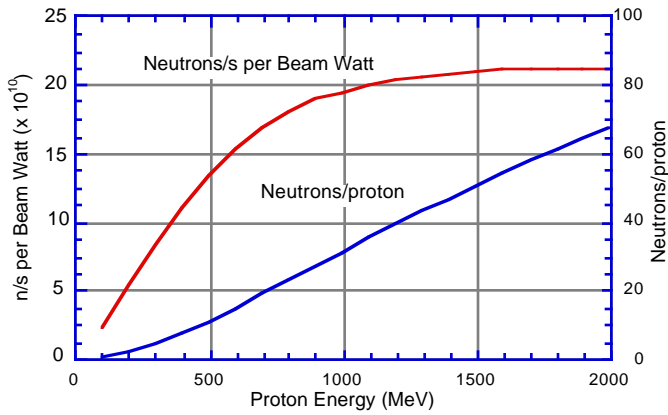

Fig. 2 Neutrons/s per beam Watt, neutrons per proton, for a beam incident on axis of cylindrical W target 50-cm diam. x 100-cm long.

models guide the choice of beam current and energy and help with the selection of other parameters, such as RF field gradient, and cavity frequency. In SRF linacs, the elimination of cavity wall losses modifies the argument, since accelerator electrical efficiency becomes nearly independent of energy. In cyclotrons, because of the repeated acceleration of beam by the same cavities, the accelerator efficiency dependence on energy is similar in shape to that of linacs, but at 20 times lower currents.

III. ADTT CONCEPTS

A. Target/Blanket Concept

All Los Alamos concepts for ADTT systems assume the beam from a single high-power linac is distributed to six 500-MWt subcritical assemblies, providing a total blanket power of 3000 MWt. Fig. 3 shows a typical module. The beam is delivered vertically through a vacuum window to an axial liquid Pb/Bi target, which provides spallation neutrons to the surrounding graphite-moderated blanket. The blanket contains materials to be burned in the form of fluorides dissolved in a molten LiF/BeF₂ salt carrier. Outside the blanket is a graphite reflector to minimize neutron leakage. The average power density in the core is 6 W/cm³, and the average neutron flux is 1.2×10^{14} n/cm². The molten salt blanket is based on technology developed at ORNL in the 1960s.

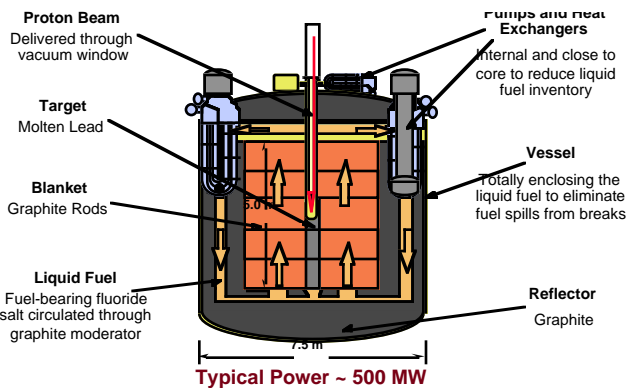

Fig. 3 ADTT molten salt target/blanket concept

In contrast with Los Alamos ADTT schemes, the thermal "energy amplifier" scheme proposed by the CERN group assumes a 10 MW beam driving a single 400-MWt target/blanket subcritical assembly. The CERN concept uses liquid lead not only for the target but also as the blanket coolant, and uses solid (MOX) fuel elements [2]. The liquid lead technology has been extensively developed in Russia.

B. Transmutation of Nuclear Waste (ATW)

ATW systems are designed to destroy the nuclear waste from commercial power plants. Spent LWR fuel, is preprocessed to remove U and Zr, which is recycled. Th232 or weapons-Pu is added to the residue to provide the desired neutron multiplication, and the mixture is inserted into the blanket to be burned. Pu and higher actinides are fissioned, and long-lived fission products are transmuted to shorter lived or stable isotopes. With an 800-MeV, 200-mA CW linac driver, 1200 MWe is produced in the target/blanket modules; 450 MWe is used to power the accelerator, leaving 750 MWe available to the power grid. Each ATW system can handle the spent fuel of 4 LWRs of equal thermal power. Fission products are continuously extracted from the blanket and separated into two groups. Long-lived isotopes (Tc99, I129, Cs135, & others), which are the species of long-time-scale concern for the biosphere, are returned to the blanket for transmutation, while short-lived species (Cs137, etc.) are sent to engineered storage for natural decay (30-yr halflife).

C. Plutonium Burning (ABC)

The scheme for destruction of weapons-Pu provides a deep burn, destroying >99% of the material, with no fuel fabrication and reprocessing. The feed is pure Pu, which is inserted continuously in the blanket to maximize the burn depth; no new Pu from fertile isotopes is generated during the process. The ABC residue is useless for weapons purposes and can be sent to a geologic repository, or the fission products can be separated for transmutation. Using an 800-MeV, 100-mA CW linac, an ABC plant produces 1200 MWe, with 300 MWe needed to power the accelerator and 900 MWe available for the grid. An alternative Pu-burning system, proposed by General Atomics, is a hybrid reactor/accelerator scheme. Three modular helium-cooled gas reactors (MHRs) burn the weapons-Pu until the buildup of fission-products exceeds a specified value, generating electricity with high efficiency. The residual material is then burned to very low Pu levels in an accelerator-driven MHR.

D. Energy Production (ADEP)

The Los Alamos energy production concept (ADEP), converts plentiful Th232 into U233 and burns it in a molten-salt blanket, while concurrently transmuting the long-lived fission products that are generated. The fuel is natural Th, which is completely utilized without excess fissile fuel breeding. The system can be started with low-enrichment U, weapons-Pu, spent LWR fuel, or power from the grid. A representative ADEP system has beam requirements and electric power distribution similar to ABC. Preliminary economic analysis shows that ADEP plants could be competitive with

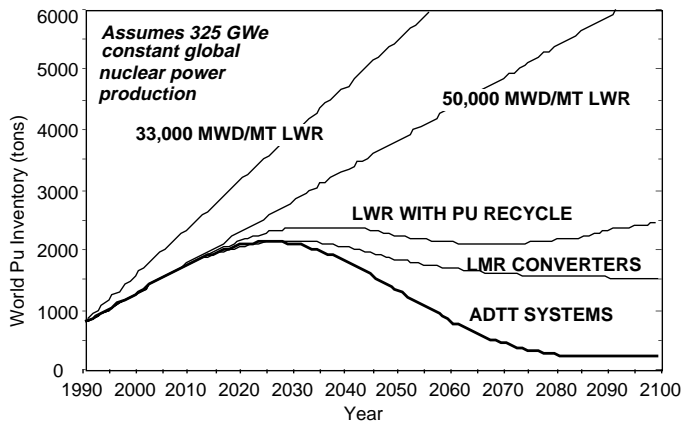

Fig.4 Estimated world Pu inventory for fission energy systems based on LWR, LMR, and ADTT fuel cycles.

conventional LWRs when all fuel cycle costs are included, and the need for long-term geologic storage of radioactive wastes would be drastically reduced.

A major benefit of ABC and ADEP systems is that they would destroy completely the Pu from decommissioned weapons, burn down the rapidly growing inventory of Pu in the spent fuel of the world's power reactors, and would not produce any new Pu. Fig.4 indicates how ADTT systems compare with several kinds of reactors and reactor fuel cycles in terms of the projected growth of world Pu inventory.

IV. CONVENTIONAL RF LINACS

A. Designs and Architectures

Representative Los Alamos high-power linac designs [3] for producing the same neutron source strength are shown in Fig.5. Both begin with low-energy linacs consisting of a microwave-driven H^+ injector, a 7-MeV 350-MHz RFQ, and a 20-MeV 350-MHz DTL. The high-energy system consists of a 100-MeV, 700-MHz CCDTL (coupled-cavity drift-tube linac) [22] followed by a 700-MHz side-coupled linac that accelerates the beam to full energy. Both use a focusing lattice with a $10\text{-}\beta\lambda$ period, and have an average accelerating gradient (E_0T) of 1.0 MV/m. An important design feature for attaining very low beam losses is a large ratio of structure aperture to rms beam size. The aperture ratio increases from 13 at 100 MeV to 26 at 1000 MeV, and is obtained through a combination of low beam emittance and high focusing strength per unit length. Other features of the design are 1) there are no significant acceptance transitions above 20 MeV, and 2) the focusing lattice tune is nearly independent of current, which simplifies beam turn-on.

The accelerator in Fig.5-top provides a 100-mA, 1000-MeV beam (100 MW) using a single low-energy linac. The version in Fig.5-bottom provides a 750-MeV beam at 150 mA (112.5 MW), using a funneling scheme. Electric power requirements for the funneled and non-funneled system are similar, because the increased electrical efficiency of the high current solution is offset by its lower neutron production efficiency. Construction costs of the funneled system are lower because of the reduced accelerator and tunnel length. In

addition to cost, funneling [5] provides other advantages, including filling all RF buckets in the high-energy linac, thus minimizing the charge per bunch. Preliminary experiments [11] have confirmed funneling principles, but a more comprehensive operational demonstration is needed.

Two different ADTT linac concepts for 1.5-GeV linacs have been described by ITEP and MRTI in Moscow. The ITEP design for a 300-mA system [14] avoids funneling by using a low-frequency RFQ (75 MHz) that can accelerate the current in a single channel. A 150-MHz DTL accelerates the beam to 150 MeV, and a 900-MHz disk-and-washer (DAW) CCL takes the beam to 1.5 GeV. Because of the low RFQ frequency, only one out of every 12 RF buckets in the CCL contains a bunch, so the charge per bunch is an order of magnitude greater than in the LANL design. The CCL gradient is comparable to the LANL choice, but because the current is higher, the overall RF efficiency is greater, 0.89. Aperture factors are estimated to range from 5.5 to 8.7.

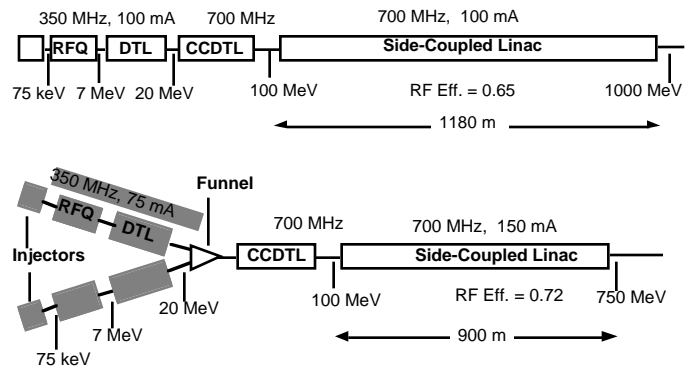

Fig 5 Representative Los Alamos ADTT linac designs.

MRTI has proposed a novel linac architecture [13] based on the use of 5 - 7 Tesla superconducting solenoids external to the accelerating structures to provide beam envelope control, thus completely separating the accelerating and focusing functions. The low energy linac begins with a 350-MHz HILBILAC accelerating a 250-mA beam to 3 MeV. This structure is followed by a conventional 350-MHz DTL accelerating the beam to 100 MeV, and finally a high energy DAW CCL operating at 1050 MHz. The external focusing scheme offers advantages in terms of beam dynamics and overall efficiency, but the superconducting solenoids could introduce operational complication.

B. Beam Physics, Beam Losses, and Halo

In high intensity ADTT linacs, a major concern is activation from beam loss in the accelerator [21]. Advances in theory and control of high-current beams achieved in the past decade (high structure frequencies, strong focusing, ramped gradients, careful matching, avoidance of large acceptance transitions, equipartitioning, etc.) provide a starting design framework for managing rms beam properties [12], but attention must also be paid to the small fraction of particles far from the core (the halo) [8,17]. Allowed beam losses are in the range 0.1 nA/m to 1 nA/m, depending on proton energy, to assure contact maintainability. This translates to $10^{-8}/m$ to $10^{-9}/m$ beam loss allowances for high-intensity ADTT linacs.

To reach such a low loss levels, the apertures in the accelerating structures and focusing elements must be large enough to contain not only the beam core but also the halo.

Experience with the LAMPF proton linac provides the best information on the potential for achieving ultra-low losses in ADTT linacs. Activation measurements following several-month operating periods at 1-mA average current show that these losses are very low through most of the CCL ($< 2 \times 10^{-7}/\text{m}$), leading to radiation levels $< 5\text{-}10$ mR/hr, compatible with hands-on maintenance. ADTT linacs need to achieve fractional loss levels 10-100 times lower, a challenging objective, but one that is achievable with the much larger aperture factors attainable in modern linac designs, the greatly improved understanding of matching and emittance control, and the greater precision of beam diagnostics and control.

Much work has been done recently on understanding the factors producing beam halos, and on how to design linacs to minimize halo growth [7,16,18,23]. Several groups are carrying out analysis and simulation using a model picturing a resonant interaction between beam-edge particles and a core undergoing density and size oscillations due to transverse or longitudinal mismatches. Simulations with very large numbers of particles ($10^6 - 10^7$), using massively-parallel computers, have progressed from simple 1-D cases to 3-D representations of FODO channels including accelerating gaps. These simulations generally confirm the principal analytical results, which are that halo production depends strongly on the degree of mismatch, and to a weaker extent on tune depression. They also show there is a limiting radial amplitude for halo particles, at a few times the core rms radius.

C. Electrical Efficiency

To minimize operating costs, the electrical efficiency of ADTT linacs must be high. Two main factors are involved, the RF generator dc-rf conversion efficiency [6], and the cavity efficiency (beam loading). With regard to the first factor, contemporary high-power klystrons have efficiencies around 0.55-0.60 when control margin is accounted for. In advanced RF generator concepts currently being investigated (klystrode, magnicon, advanced klystron), there is the expectation that the dc-rf efficiency could be raised as high as 0.75.

To maximize the second factor, there are three parameters to consider, accelerating gradient, cavity shunt impedance, and beam current. Cost models show that a low structure gradient (1.3-1.5 MV/m) is generally optimum for CW operation, a result of the high cost of RF power relative to other elements of the linac as well as the dominance of electric power cost in the the total operating cost. The gradient also affects capital cost through length-related factors. Cavity shunt impedance can nominally be increased by going to higher-frequency structures, but in practice this improvement is restricted by the need to maintain large cavity apertures for low beam loss. The optimum operating frequency for the high-energy part of an ADTT linac (CCL) is from 600 to 1000 MHz. For conventional copper linacs, beam currents need to be ≥ 100 mA for highest cavity efficiencies.

E. Availability; RAM Modeling

With the incorporation of accelerators into materials production/destruction and power generating roles, a systems assessment of reliability, availability, and maintainability (RAM) becomes an important aspect of design. The requested availability of the production plant is typically $> 75\%$, so the linac must have an availability $> 85\%$. The use of RAM models (based on fault-trees and component reliability statistics or estimates) in system design is being incorporated in accelerator design for ADTT applications.

RF station availability is one of the major concerns for a linac having 200-400 klystrons. With projected tube lifetimes of 25,000 hours, failure rates can be on the order of 2-3 per week. A station fault can cause a large enough local energy deficiency to interrupt acceleration. New Los Alamos linac designs are studying the concept of dividing the accelerator into "super-modules" which each include an extra RF tube; the coupled accelerating structure acts as an RF combiner. When an RF tube fails, the remaining units increase their output power to compensate, allowing the failed unit to be serviced or replaced without a significant beam interruption.

V. CYCLOTRONS

The CERN ADTT group is studying Th232/U233 ADEP schemes [2] which have beam drive requirements in the 10-20 MW range. For such relatively modest beam requirements, the possibility of using cyclotron technology comes into play. The CERN group, is developing a concept based on a 3-stage cascade of cyclotrons [20], with each chain delivering a 10 mA beam at 1,000 MeV (10 MW). Cyclotron designers at PSI are also assessing the feasibility of such a machine [4]. In one scheme, depicted in Fig. 6, the cascade begins with two 10-MeV isochronous cyclotrons injecting 5-mA beams into a 120-MeV intermediate-energy 4-sector cyclotron. This machine delivers a 10-mA beam to a 10-sector ring cyclotron that accelerates the protons to approximately 1000 MeV. The final stage is an extension of the 590-MeV ring cyclotron design at

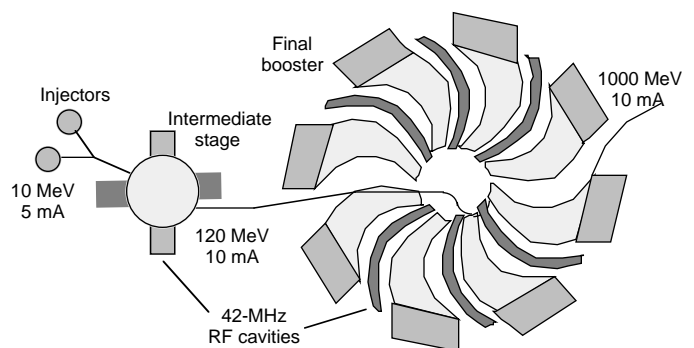

Fig. 6 CERN/PSI multi-stage cyclotron scheme for producing a 10 MW beam at 1 GeV.

PSI, which has recently been upgraded to operate at 1.5 mA. The operating frequency of the cascade is 42 MHz.

The perceived advantages of a cyclotron scheme for the 10-MW power range are compactness and high power effi-

ciency at relatively low beam currents. The latter property derives from the large number of beam orbits passing through each RF cavity; a cavity efficiency of 0.70 is achieved with a 10 mA beam, leading to an overall machine efficiency of 0.40, similar to that of a 200-mA linac. The CERN ADEP scheme would drive a single target/-blanket module with a 10-MW beam, producing 400 MWt, which would generate 155 MWe. About 25 MW would be needed to run the accelerator system, leaving 130 MWe for export to the grid.

Design issues for an advanced high-power cyclotron lie in the details of transverse and longitudinal beam dynamics, in achieving large orbit separations for low-loss extraction, and in how to supply the large RF power needed in each cavity to provide the requisite energy gain per turn. To obtain low extraction losses, the number of turns in the high-energy cyclotron must be low (140), implying an energy gain of 6 MeV per turn. For reference, extraction losses in the upgraded PSI cyclotron are $< 2 \times 10^{-4}$ at 1.0 mA, which is a tolerable. In addition to the localized extraction loss there is concern over distributed beam loss inside the cyclotron from beam halo.

Cyclotron designers believe that 10 mA is achievable in an advanced cyclotron using conventional (pole-edge) focusing and conventional RF cavities. To go further would probably require a strong-focusing system using very high energy gain per turn, as in a separated orbit cyclotron (SOC). Such a system, which might require superconducting RF cavities and superconducting magnets, could be based on the design developed for a small superconducting SOC prototype being built at U. Munich for heavy ion beams [19].

VI. SUPERCONDUCTING RF LINACS

The growing maturity of superconducting RF (SRF) technology provides a potentially attractive alternate approach for high-intensity proton linacs [15]. The advantages of an SRF accelerator would be significantly reduced operating costs because of the elimination of RF wall losses, higher gradients which could reduce linac length, and larger structure apertures, which would reduce the beam loss threat. The operating power advantage increases as the beam power requirement decreases; for a 100 MW beam requirement, the electric power reduction is about 20%.

A possible SRF-based design to compete with the 100-MW linac concepts in Fig.5 might involve a conventional low-energy linac (to 100 MeV), followed by a high-energy SRF linac based on multi-cell elliptical cavities. Preliminary design parameters could be 1.2 GeV, 80 mA CW, 700-MHz SRF cavities combined in groups of 2-4 (depending on β), with each group fed by a 250-to-400-kW power coupler.

Design issues specific to high-intensity proton linacs [9] include the complexity of structure assembly, long-term availability, the necessity for low-temperature (2-4K) refrigeration, the lack of proven medium- β accelerating structures, and power coupler limitations. In addition, it is necessary to gain experience in operation of prototype SRF cavity systems with high-current beams. The practical gradients that can be realized will generally be bounded by the power coupler performance. This technology has made significant advances in

the past year or so, and many believe that 300-500 kW per coupler will soon be practical.

VII. ACKNOWLEDGEMENTS

The author thanks F. Venneri and E. Heighway of the Los Alamos ADTT Group for helpful updates on transmutation technology and applications, and colleagues in the Accelerator Division for useful comments on the draft of this paper.

VIII. REFERENCES

- [1] C.D. Bowman, "Overview of the Los Alamos Accelerator-Driven Transmutation Technology Program", Proc. of 1994 International Conf. on Accelerator-Driven Transmutation Technologies and Applications, Las Vegas, July 25-29, 1994.
- [2] C. Rubbia, "The Energy Amplifier Concept: A Solid-Phase Accelerator -Driven Subcritical Th/233U Breeder for Nuclear Energy Production with Minimal Actinide Waste", *ibid.*
- [3] G. Lawrence, "Los Alamos High-Power Proton Linac Designs", *ibid.*
- [4] Th. Stammbach, S. Adam, H.R. Fitze, W. Joho, and U. Schryber, "Potential of Cyclotron-Based Accelerators for Energy Production and Transmutation", *ibid.*
- [5] S. Nath, "Funneling in LANL high intensity Linac Designs," *ibid.*
- [6] M. Lynch, et al., "Important Requirements for RF Generators for Accelerator-Driven Transmutation Technologies", *ibid.*
- [7] R. Ryne, "Recent Results in Analysis and Simulation of Beam Halo", *ibid.*
- [8] M. Reiser, "Beam Physics Design Strategy for a High-Current RF Linac", *ibid.*
- [9] J.R. Delaysen and C.L.Bohn, "Overview of Superconducting RF Technology and its Application to High-Current Linacs", *ibid.*
- [11] K.F. Johnson, et al., "The Single-Beam Funneling Demonstration: Experiment and Simulation", Proc. 1990 Linear Accelerator Conf., Albuquerque, NM, September, 1990, pp. 701-703.
- [12] T.P. Wangler, et al., "Linear Accelerator for Production of Tritium: Physics Design Challenges", *ibid.* pp. 548-552.
- [13] B.P. Murin, et al., "High-Current Low-Energy RF Ion Accelerator", *ibid.*, p. 707-709.
- [14] I.M. Kapchinsky, et al., "Linear Accelerator for Plutonium Conversion and Transmutation of NPP Wastes", Proc. 1993 Particle Accelerator Conf., Washington DC, May 1993, pp. 1675-1680.
- [15] J.R. Delaysen et al. "Design Considerations for High-Current Superconducting Ion Linacs", *ibid.*, pp. 1715-1717.
- [16] J.S. O'Connell, et al, "Beam Halo Formation from Space-Charge Dominated Beams in Uniform Focusing Channels", *ibid.*, p. 3657-3659.
- [17] R.A. Jameson, "Design for Low Beam Loss in Accelerators for Intense Neutron Source Applications", *ibid.*, p. 3926-3930.
- [18] J.M. Lagniel, "Chaotic Behaviour Induced by Space Charge", Proc. 1994 European Particle Accel. Conf., London, June 1994.
- [19] U. Trinks, "Exotic Cyclotrons – Future Cyclotrons", Proc. CERN Accelerator School, LaHulpe, 1994, to be published.
- [20] C. Rubbia, P. Mandrillon, and N. Fetier, "A High-Intensity Accelerator for Driving the Energy Amplifier for Nuclear Energy Production", Proc. 1994 European Particle Accelerator Conference, EPAC94, London, June, 1994, 270-272.
- [21] G.P. Lawrence, "Critical Design Issues of High-Intensity Proton Linacs", *ibid.* 236-240.
- [22] J.H. Billen et al., "A Versatile High-Power Proton Linac for Accelerator-Driven Transmutation Technologies", Proc. 1995 Particle Accelerator Conf., Dallas, TX, May 1-5, 1995.
- [23] R.D. Ryne, "Halos of Intense Proton Beams," *ibid.*