

# NON INTEGER HARMONIC NUMBER ACCELERATION OF LEAD IONS IN THE CERN SPS

D. Boussard, T. Bohl, T. Linnecar, U. Wehrle, CERN, 1211 Geneva 23, Switzerland

## Abstract

The project to accelerate lead ions in the CERN complex has been successfully completed and physics has begun. In the SPS, the final machine in the chain, the ions are accelerated from an energy of 5.1 GeV/nucleon to 160 GeV/nucleon using the existing 200 MHz travelling-wave cavities. The change in revolution frequency during acceleration is much larger than can be accepted by the untuned cavities when operated at constant harmonic number. A technique has been developed to overcome this limitation which takes advantage of the filling time of this type of cavity which is shorter than one turn. Fast amplitude and frequency modulation of the RF waveform allows the cavities to operate at a constant, optimum frequency during the passage of a batch of particles in the structure. This frequency is not a multiple of the revolution frequency and therefore during the gaps between batches the phase of the composite RF waveform is changed to maintain synchronism from turn to turn as the beam accelerates. The technique and hardware are described in detail together with the first operational experience.

## I. THE SPS TRAVELLING-WAVE CAVITIES

The SPS is a high intensity proton synchrotron with an injection energy ranging from 10 GeV to 26 GeV. The RF frequency swing during acceleration up to 400 GeV is therefore fairly small ( $4.4 \times 10^{-3}$ ). This fact has been exploited in the design of the RF cavities, which are of the travelling wave type, like in an electron linac, for instance [1].

Each cavity is a chain of coupled resonant cells, which behaves like a backward transmission line. The RF power is fed at the downstream end and dumped in a matched load at the upstream end of the structure. The major characteristics of the SPS RF system are given in Table 1.

Table 1

RF frequency at	199.5 MHz (10 GeV)
harmonic number $h = 4620$	200.4 MHz (400 GeV)
Cavity centre freq. ( $\omega_0/2\pi$ )	200.22 MHz
Operating mode at $\omega_0$	$\pi/2$
Cell length ( $\beta\lambda/4$ )	374 mm
Group velocity $v_g/c$	-0.0946 (backward wave)
Cavity length	
two units of $\ell =$	20.2 m (54 cell cavity)
two units of $\ell =$	16 m (42 cell cavity)
Cavity voltage at 500 kW	2.35 MV (54 cell cavity)
transmitted power	1.86 MV (42 cell cavity)

One major advantage of such cavities is their inherent bandwidth, determined by the phase slip  $\theta$  between particle and wave along the structure. For a cavity of length  $\ell$ ,  $\theta$  is given by:

$$\theta = \frac{\ell}{v_g} (\omega - \omega_0) - \ell \left( \frac{\omega}{v} - \frac{\omega_0}{v_0} \right) \quad (1)$$

RF wave                      particle

where  $\omega_0/2\pi$  and  $v_0$  are the synchronous frequency and the synchronous particle velocity respectively.

In the classical constant harmonic number acceleration, for protons,  $\omega/v$  is constant and equation 1 reduces to its first term only. The energy gain through a cavity traversal is reduced by the transit time factor:

$$T = \sin(\theta/2) / (\theta/2)$$

with respect to the maximum obtained for the synchronous condition ( $\omega = \omega_0$ ,  $v = v_0$ ).

At the minimum injection energy of 10 GeV,  $T$  is reduced by only a factor 0.7 which is perfectly acceptable and shows one of the great advantages of the travelling wave cavities, namely no need for a programmed or a servo tuning system.

The SPS is also used for lead ion acceleration [2], with an injection energy of 5.08 GeV/c/u corresponding to  $T = -0.113$  (short cavities) and  $T = 0.099$  (long cavities). The standard  $h = 4620$  acceleration would not work in this case, as the RF effective voltage would disappear as acceleration proceeds. To avoid building a new, dedicated RF system for ion acceleration, one can look again at eq. 1 and assume that the RF frequency  $\omega$  is a free parameter. In this case  $\theta$  can be made to vanish, for the optimum frequency  $\omega = \omega_0(\ell - v_g/v_0)/(\ell - v_g/v)$ . As  $v_g \ll v, v_0$ , this corresponds approximately to  $\omega = \omega_0$ .

For constant  $h$  acceleration, the centre frequency of classical resonant cavities follows the particle velocity. In this case a large fraction of their stored energy is still useful for acceleration after one machine turn. This is not the case for the SPS cavities because of their travelling wave nature: the energy stored in the resonant cells propagates to the matching load in a time  $\ell/v_g$  short compared to the revolution period of 23  $\mu$ s. In other words the cavities have no memory after one turn, and therefore *can be powered at their optimum frequency, provided there is a gap in the RF waveform — and in the beam* — to let the structure be emptied (and filled) at every turn. In this way, at each turn, we have a new, independent acceleration event, optimized to obtain the best efficiency of the structure.

## II. HOW TO RESYNCHRONIZE WITH THE BEAM AT EVERY TURN

Although it is not a new idea [3] to use an RF burst frequency  $\omega \approx \omega_0$  different from  $h f_{rev}$  ("non integer harmonic number acceleration"), the problem of keeping the successive RF bursts in perfect synchronism with the orbiting beam has

to be faced. This is imperative to avoid excessive radial excursions especially close to the transition energy.

The solution is an FM modulated wave, with a rectangular modulation periodic at the revolution frequency  $f_{rev}$  (Fig. 1) [4]. The average (carrier) frequency is  $h f_{rev}$  but the frequency during the useful RF burst can be made equal (or close to)  $\omega_0/2\pi$  to optimize the cavity behaviour. The various revolution frequency clocks (and therefore the modulation waveform) are obtained by divide-by- $h$  counters on the FM modulated signal  $f_{RF}$ .

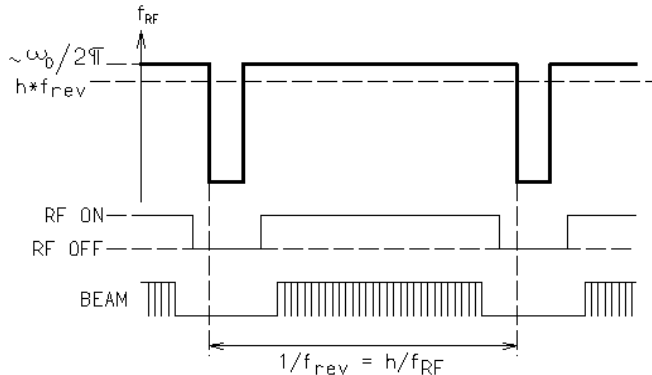

Fig. 1. FM-modulated RF

A fast voltage-controlled oscillator (VCO) is driven by two sources (Fig. 2): a) a slowly varying control voltage which defines  $h f_{rev}$ , and b) a fast modulation, with zero average (AC coupled) synchronous with  $f_{rev}$ , and which keeps the RF burst frequency close to  $\omega_0/2\pi$ .

The first control voltage is obtained from the classical phase, radial or frequency loops and plays the same role as usual. The modulating voltage is derived from a frequency programme (the modulating amplitude is proportional to  $\omega_0/2\pi - h f_{rev}$ ). During the off time of the cavities the VCO runs far away from  $h f_{rev}$  (especially for short gaps), which imposes severe constraints on the linearity and speed of the oscillator.

Clearly this scheme will also work with more than one batch of ions around the circumference provided the cavity filling times are sufficiently short.

### III. THE VOLTAGE-CONTROLLED OSCILLATOR

The main characteristics are given in Table 2. The oscillator is basically simple with an LC tank circuit consisting of a low-loss transmission line for the inductor and a high Q varicap, and two low-loss FETs in the feedback path. The components in the feedback and drive circuits are carefully chosen for their speed, temperature stability and noise properties. The latter is particularly important due to the high sensitivity of the oscillator. Noise measurements show that the static, non-switching, phase noise level is similar to that used for high intensity proton operation. The linearity was improved by external correction to  $\pm 2.5$  kHz to limit the correction swing needed from the phase loop amplifier (DC input).

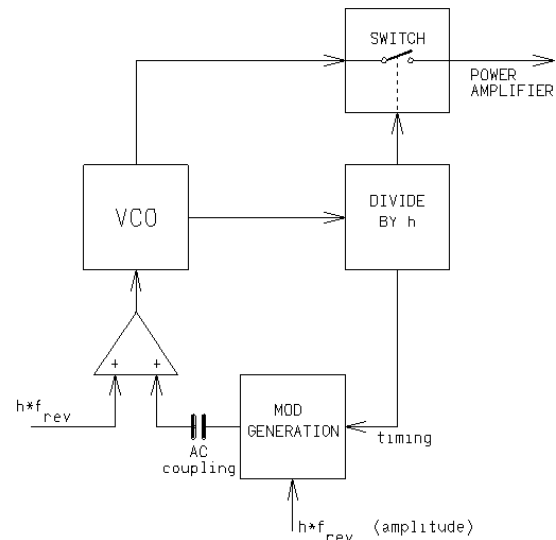

Fig. 2. Principle of the VCO drive

Table 2. VCO Characteristics

Max. freq. range	177.1 - 191.7 MHz
DC/AC Sensitivity	2 MHz/V
Non-linearity	$\pm 2.5$ kHz
Output power	0 dBm
Temperature Stability	$< 2$ kHz / $^{\circ}$ C at 25 $^{\circ}$ C
AC switching speed	200 ns, full range
DC bandwidth	$> 250$ kHz
Noise at 1 kHz, 10 kHz	-78dBc, -100dBc

### IV. THE RF SYSTEM

Four batches of ions, 2.2  $\mu$ s long, are injected equispaced around the circumference, at 1.2 s intervals. During this process the mean RF frequency is locked using the synthesiser loop to the injection/capture frequency also sent as revolution frequency information to the injector. Each batch partially debunched in the SPS is independently adiabatically captured using fast counterphasing modulation at  $4f_{rev}$  on two cavity voltages to produce the required capture function. After the injection process the radial loop is used to accelerate the beam from 5.08 GeV/c/u to 157.8 GeV/c/u.

A simplified block diagram of the RF system is given in Fig. 3. The synthesiser loop compares the injection frequency with the modulated RF, the output of the mixer being sampled at  $4f_{rev}$  to provide the correction signal to the VCO. The main cavity phase and amplitude control circuits and the beam/RF phase discriminator work at an intermediate frequency, IF, of 10.7 MHz. The VCO works at  $f_{RF} - 10.7$  MHz and input and output mixers are used. The VCO and the RF switch which allows drive to the amplifiers only when the modulated frequency is suitable, are switched at  $4f_{rev}$  (173 kHz), with a mark-space ratio of 3.63  $\mu$ s to 2.13  $\mu$ s using external trigger pulses derived by division of the modulated RF. The total oscillator frequency swing is then  $\approx 7$  MHz compared to the IF of 10.7 MHz. The filters in the output mixer are quite critical with a rejection of the local oscillator signal greater

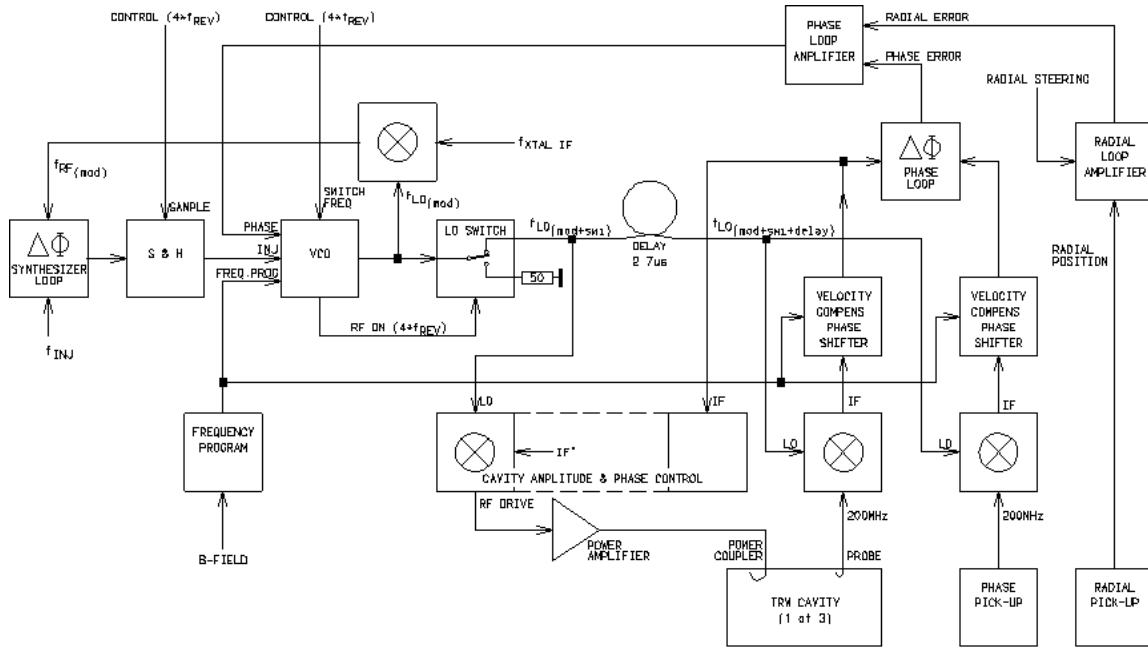

Fig. 3. Simplified block diagram of the RF system

than 20 dB, 3 MHz from the passband where the phase response is  $\pm 10^\circ$ .

At constant harmonic number the number of bunches between elements in the machine is fixed during acceleration. This is not so with this scheme; the RF phase varies with velocity and must be compensated by phase shifters programmed according to the revolution frequency. The information is not available from the bunch frequency, (fixed frequency acceleration). The long delays, surface to tunnel, also require compensation so that synchronism between the RF burst on the surface and that generated from the cavities or by the beam is obtained at the measurement points.

The amplitude circuits in the cavities have narrowband filters to eliminate revolution frequency components. This means that they measure mean RF voltage as opposed to peak and must be corrected according to the mark-space ratio. The power measurements used to protect amplifiers and cavities use peak detection and are not affected by this scheme. The amplifiers themselves required considerable modification in the power supply regulation circuits to permit this fast switching at full power, 500 kW/amplifier.

## V. RESULTS WITH Pb BEAM

Fixed frequency acceleration worked well from the beginning of the physics run. As optimisation of the various transverse and longitudinal parameters proceeded, the overall transmission in the SPS rose from 50 to 75%. Capture efficiencies were about 80%.

The optimum operational voltage to hold the ions along the injection plateau corresponds to a bucket height comparable to the injected momentum spread. In principle, good adiabatic capture requires a value approximately twice this. However, raising the voltage produces a diffusion loss of particles from the bucket which becomes important during the

3.6 s holding period. The phase noise measured on the beam suggests diffusion rates of the order of seconds and indeed injecting white noise into the RF to double the observed phase noise produces loss rates similar to that with higher voltages. Diffusion rates increase with the square of the synchrotron frequency for a flat noise spectrum. Detailed measurements point to the high frequency noise, at multiples of the revolution frequency, in the VCO as the source. It may therefore be possible to increase the capture efficiency, already good, by using higher voltage if the noise on the VCO can be reduced.

In conclusion, fixed frequency acceleration has proved a powerful method for extending the capabilities of the existing SPS as a particle accelerator.

## VI. ACKNOWLEDGEMENTS

Many people in the RF/LS (beam control) and RF/CP (power) sections have contributed to the success of the lead ion acceleration. In particular we thank H-P. Kindermann, W. Sinclair and F. Oude-Moleman for their work on the power amplifiers.

## VII. REFERENCES

- [1] G. Dôme, CERN SPS/ARF/77-11.
- [2] A. Faugier *et al.*, this conference.
- [3] C. Zettler, CERN LABII/RF/CZ/Note 75-32.
- [4] D. Boussard, J.M. Brennan, T.P.R. Linnecar, CERN SPS/89-49 (ARF).