

# Digital Signal Array Processor for NSLS Booster Power Supply Upgrade\*

R. Olsen, J. Dabrowski,  
National Synchrotron Light Source, Brookhaven National Laboratory  
Upton, New York 11973

J. Murray  
SUNY Stony Brook  
Stony Brook, New York 11794

## Summary

The booster at the NSLS is being upgraded from 0.75 to 2 pulses per second. To accomplish this, new power supplies for the dipole, quadrupole, and sextupole have been installed. This paper will outline the design and function of the digital signal processor used as the primary control element in the power supply control system.

## INTRODUCTION

The booster power supply controllers operates in the z domain (1). Since many functions were required to be performed in parallel using interrupt frequencies from 180 Hz to 92.160 KHz, it was clear that parallel processing would be required. In addition, the uneven distribution of real-time required in the various circuit nodes implied a processing element where the processors could be assigned on an as-needed basis. This paper outlines the design and function of the Digital Signal Array Processor (DSAP) designed to be used for the booster power supply upgrade.

## PRELIMINARY DESIGN REQUIREMENTS

The choice of VMEbus for the control system and a 6U, 160 mm format for the host processor dictated the size of the processor module. Downloading and supervision was to be performed by means of the VMEbus, thereby using up a considerable portion of the available bandwidth. Therefore, the VSB (VME secondary bus) is employed for interprocessor communications. Communication between the DSAP and application modules such as the trigger generator (TGEN), servo data I/O channel (SDIC), or phase locked loop (PLL) takes place over a board to board internal bus (the P3 connector). Thus, a DSAP module would normally be mated with an application module. Reliability and fault diagnosis dictated that the static RAM be provided with error detection and correction (EDAC). The need to provide a wide range of processing capability and the relative complexity if the I/O structure dictated the use of a mother board holding the I/O

bus hardware and a minimal number of DSP elements, while using a mezzanine board to hold an array of DSP elements which may be added as required. In the immediate case, the processor used is the TMS320C31, however, another processor, such as a special purpose FFT engine could be employed.

## I/O CONTROL

Since I/O takes place over the VME and VSB bus, we use a 68030 as a bus controller, a Newbridge Microsystems CA91C078 as the VMEbus interface, and the PLX VSB1400 and VSB2000 as the VSBbus master and slave respectively. The CA91C078 provides all interface functions to the 68030 such as interrupt handling, local bus requestor, mailbox, VMEbus DMA, and address decoding, with no glue logic required. In addition, it provides the address mapping for the VSBbus master. The 68030 bus functions are closely enough matched to the VSBbus protocol so as to require a bare minimum of glue logic. A serial port is provided mainly to assist in debugging the I/O controller using a local monitor and a debugger resident on a PC. A math coprocessor is provided to allow DSP functions to be performed locally during idle time. The 68030 is provided with 128K by 32 bit words of SRAM (CYM1836) which is error corrected (IDT49C465). VSBbus DMA is provided by a TMS320C31. Programming for this function resides in the internal 2K RAM.

## SIGNAL PROCESSING

The signal processing functions of the mother board take place in a pair of TMS320C30's (Node 0,1). As may be seen from Fig. 1, they are connected in a symmetrical arrangement, and communicate with the I/O controller by means of a dual-port memory on the primary bus. Each DSP is provided with 128K words of fast SRAM (CYM1836) which is error corrected (IDT49C460). This is more than adequate to hold the operating system plus application programs. Each DSP provides for four external interrupts. Level 0 is reserved for the operating system, levels 1 and 2 are for applications and appear on the P3 connector, while level 3 is reserved for handling errors from the associated

\*Work performed under the auspices of the U.S. Department of Energy, under contract DE-AC02-76CH00016.

EDAC. Nodes 0,1 may be synchronized by means of the interconnected flags XF0,1 using the SIGI assembler instruction.

## GLOBAL BUS

The processor nodes 0,1 communicate with a global resource by means of their expansion bus. Each processor bids for the bus for each transaction. Arbitration is performed by means of a synchronous state machine (CY7C330). This global resource consists of 2K x 32 SRAM for direct interprocessor communication, two 2K x 32 pages for communication to the mezzanine processors, and an 8K x 32 page for communication with the application modules.

## INITIAL PROGRAM LOADING AND EMULATION

It may be observed from Figs. 1 and 2 that the DSAP consists of a cluster of processor nodes which communicate by means of shared multi-port memory. No hardware is provided to load program directly to the memory from the VMEbus. This architecture, and its attendant great saving in hardware complexity was made feasible by using the emulator port provided on each TMS320C3X device. The emulator port consists of a five wire interface; the clock, serial data out, serial data in, and control bit 0 and 1, and conforms to IEEE 1149.1. This local emulation bus is controlled by means of a local test bus controller (74ACT8990). The TBC is a 16 bit device requiring a 5-bit address and is mapped into the VMEbus in A16 D16 short I/O address space using a dedicated VME slave interface (VME2000). The Emulator Porting Kit (2), is a software package which runs on the host processor and interacts with the user through a series of windows. It provides for downloading and uploading of files, as well as full facilities for program debugging such as reading and writing registers, single stepping, and breakpoints. Since the 68030 is not provided with an emulator port, the TMS320C31 used for VSB DMA/block transfer acts as an emulator interface to the SRAM providing the program IPL function.

## MEZZANINE BOARD

Although the mother board contains substantial processing power, in several instances it was not sufficient. To provide processing power on an as-needed basis, and also provide the flexibility of using processors other than the TMS320C3X family for special applications, the majority of processors are located on the mezzanine board. Communication with the mezzanine board is by means of two 2K x 32 memory pages one page each for the odd and even processor clusters. These processors are IPL'd by means of the emulator bus. If a processor other than TMS320C31's were to be used, a single

TMS320C31 would be provided as an IPL port, in the same manner as is used for the 68030.

## ERROR HANDLING

As noted above, each block of processor memory is equipped with EDAC. An error occurring in the I/O process area generates an interrupt to the VMEbus by means of the CA91C078. An error in node 0,1 is handled by a routine which resides in internal RAM. The error data is deposited in the dual-port memory, and an interrupt is generated to the I/O controller. The error message is then passed to the system host. Error messages are communicated on the mezzanine bus by means of a serial data link as shown in Fig. 3. A simple packet network scheme has been provided to allow direct interprocessor communication of process control messages. The serial ports are provided on the chip, and implementation of this scheme required only the interconnections between the chips.

## HARDWARE IMPLEMENTATION

The DSAP consists of a 6U, 160 mm, single width module. The printed wiring board is 18 layer with 12 signal, 3 power, and 3 ground planes, ~110 mil thick, with reliefs milled into the front side to provide 0.062 inch card guides and to recess the P1 and P2 connectors and the front panel mounts sufficiently to provide 110 mil clearance at the back side. Line width is 5 mil with 5 mil space, vias are blind and through hole and use 30 mil pads and 14 mil drill. The majority of components are SMT with the notable exception of the CA91C078 which is a 299 pin PGA and the processors. All PGA's are mounted on side 1 while SMT's are mounted on both sides. Two 9-pin D connectors are mounted on the front panel for the two RS-232 serial ports. Fourteen front panel LED's display control and status information. The module address is selected by means of two hexadecimal switches (1 of 256). All other control functions are performed by means of the VMEbus slave interface.

## ACKNOWLEDGEMENT

The authors wish to express their great appreciation to J. Rubino, J. Boheneck, and C. Neuls of the NSLS electrical drafting group for their expert assistance in the difficult task of placing and routing the printed wiring board employed in the construction of the DSAP module.

## REFERENCES

- [1] R. Olsen, J. Dabrowski, J. Murray, "Dipole Power Supply for National Synchrotron Light Source Booster Upgrade IEEE Nuclear Science Symposium, Orlando, FL, Oct. 25-31 1992, p. 572-574.
- [2] Texas Instruments

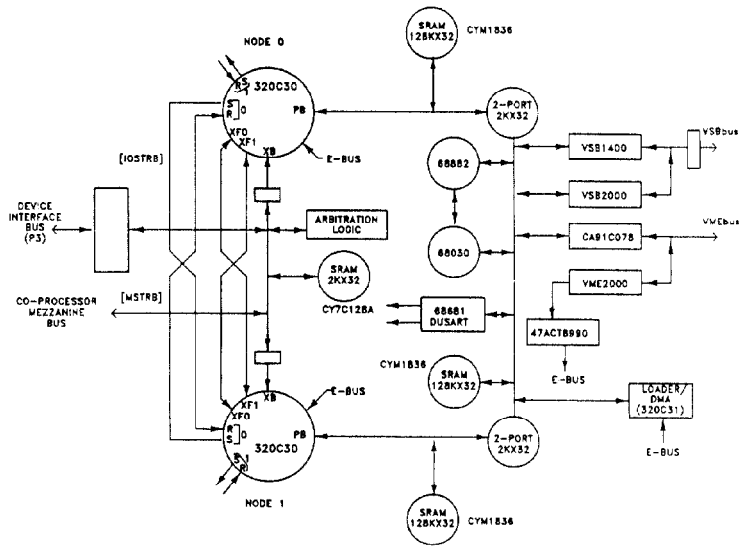

Fig. 1

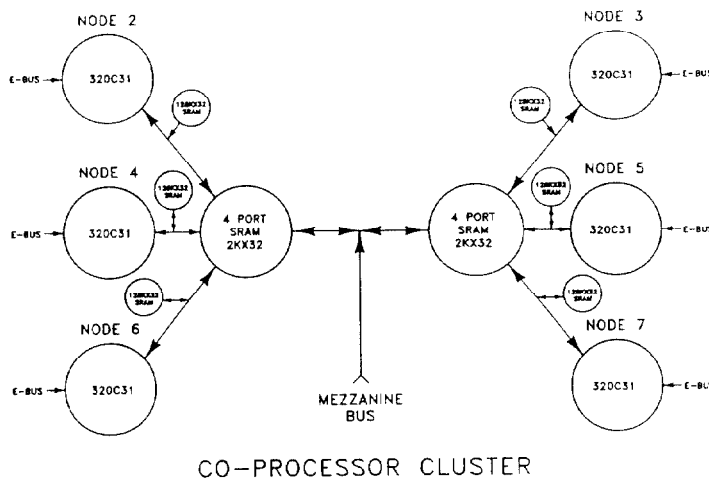

Fig. 2

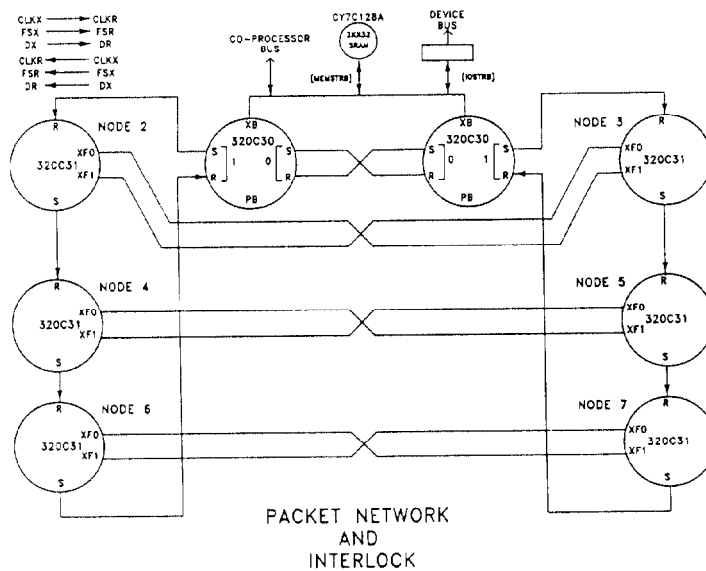

Fig. 3