

High Voltage Pulse Cable and Connector Experience in the Kicker Systems at SLAC *

K. Harris, M. Artusy, A. Donaldson, T. Mattison
Stanford Linear Accelerator Center, Stanford CA 94309

Abstract

The SLAC 2-mile linear accelerator uses a wide variety of pulse kicker systems that require high voltage cable and connectors to deliver pulses from the drivers to the magnet loads. Many of the drivers in the SLAC kicker systems use cable lengths up to 80 feet and are required to deliver pulses up to 40 kV, with rise and fall times on the order of 20 ns. Significant pulse degradation from the cable and connector assembly cannot be tolerated. Other drivers are required to deliver up to 80 kV, 20 μ s pulses over cables 20 feet long. Several combinations of an applicable high voltage cable and matching connector have been used at SLAC to determine the optimum assembly that meets the necessary specifications and is reliable.

I. SLAC KICKER SYSTEMS

There are a total of seven continuously operating kicker systems currently in use in the SLAC Linear Collider (SLC,) divided into three basic types, LC discharge kickers (for Final Focus,) Fermi-type long-pulse cable kickers, and Blumlein short-pulse kickers [1] - [4]. The primary use of the kickers are for injection and extraction of the e- and e+ bunches into the SLC damping rings, to divert e- bunches to produce e+ bunches, and to dump the beams at the final focus points. The long-pulse kickers are located in the e- north damping ring, and the short-pulse kickers are located in the e+ south damping ring and at the e+ target area, and the LC discharge kickers are for beam dumping at the final focus area. The SLC kickers systems and damping rings are described in detail in several other papers being presented at the 1991 IEEE Particle Accelerator Conference [4], [5], [7].

II. OLD KICKER CABLES AND CONNECTORS

The SLC damping ring and e+ source kickers, as previously described, are divided into two types. Figure 1 [1] shows the Blumlein short-pulse type and Figure 2 shows the Cable long-pulse type. Several types of high voltage pulse cables and connectors/connections have been used in the kicker systems at SLAC. The short-pulse kicker systems (South

Damping Ring, or SDR, and the e+ source kicker) have historically used RG-220 cable that has had the outer braid terminated outside and the polyethylene tapered and terminated inside the oil Blumlein. The cables come out of the Blumlein horizontally, and there have been failures due to the air space between the outer braid and the poly as well as the awkward mechanical support of the cable.

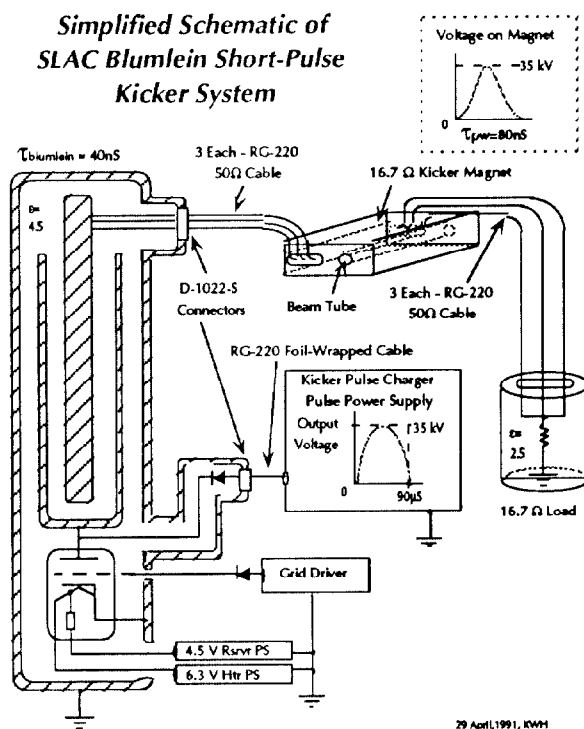

Figure 1. Short-Pulse Blumlein Kicker System.

The three cables from the Blumlein to the short-pulse kicker magnets are connected to Hugin contact bands in the magnet center conductor slab, with the ground braids clamped to cylinders on the magnet outer conductor surface. Originally the cable insulation was inserted into a cavity, formed in the RTV during magnet potting [6], without any preparation, but these connections had a high failure rate. Delrin plastic inserts are now potted into the ends to accept the cable insulation, which is tapered and greased to form an air-free connection. There have been no Delrin insert failures although there has been some corona damage. There have also been some failures in the RG-220 cables near the magnet where the ground braid

* Work supported by US Department of Energy contract DE-AC03-76SF00515

has separated from the polyethylene allowing corona underneath.

The long-pulse kicker systems shown in Figure 2 (North Damping Ring, or NDR) have used Felton & Guillaume (F&G) type HP 10.4/39.0 -50Ω/60kV coax that was very robust but difficult to obtain and quite large in diameter. RG-220 has also been used, with several types of connections. The pulsed-charger [8] cable between the thyatron tank and the pulse-charger sees ≈ 70 kV pulses with rise-times on the order of 20 μ s. The standard connection has been a tapered RG-220 feed-through with o-ring seal around the PVC jacket that allows oil from the thyatron tank to wick into the outer braid. This virtually eliminates the air voids between the polyethylene and the braid, which tend to be the primary source of cable failures. The physical connection of the RG-220 to the pulse-charger tank, however, is made at a slightly upward angle, and the outer braid is terminated outside the tank. There is a short length of cable connection that is dry and exposed. This has resulted in several cable failures.

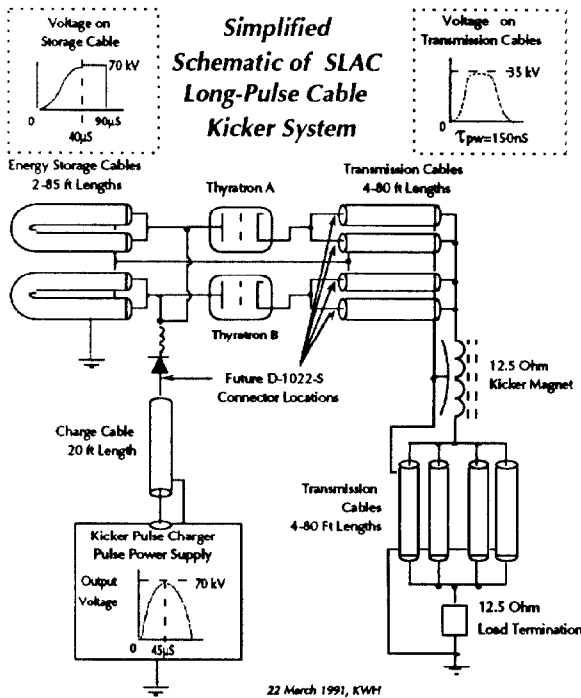

Figure 2. Long-Pulse Cable Kicker System.

The remaining long-pulse cables are currently RG-220 that are oil filled due to the just described connections. Problems associated with the cables are that oil filling is difficult, very messy, and there are almost always oil leaks from the cable that have to be dealt with. The Fermi magnets [5] associated with the long-pulse kickers are connected with four RG-220 cables at each end, with tapered and greased insulation fitting into a tapered cavity in the RTV potting of the magnet. The cable center conductors angle in to the tapered ends of the

magnet center conductor and are held by setscrews accessible through holes in the RTV that are later filled with grease. There have been some failures associated with the setscrew arrangement. The cable ground braids are clamped to tubes at the magnet ends. There have been some failures due to center conductor eccentricity because the cable polyethylene gets warm from the magnet heaters and tends to flow, and the cables enter the magnet from awkward angles with tight bends.

III. NEW CABLES AND CONNECTORS

Due to the Blumlein cable failures, an effort was made to develop a cable/connector system that was robust, reliable, compact, and as close to 50 Ω as possible for pulses up to 80 kV. Fermi and others [9], [10] have done extensive work on improving pulse coax, especially the RG-220 type. Currently, SLAC has Times AA-6778 cable installed in the short-pulse kickers between the pulse-charger and the Blumlein. AA-6778 is a version of RG-220 that has an Aluminum foil tape layer between the poly and the outer braid. This foil layer helps reduce the air pockets that cause many cable failures. Working in conjunction with Isolation Designs of Sunnyvale, CA, SLAC developed the D-1022-S connector for foil-wrapped RG-220 cable. The D-1022-S has an integrated high-voltage (HV) shield to ground to reduce field enhancement [11], oil tight Hugin type multi-lam connectors, and a tapered section for void-free poly fit. The D-1022-S is shown in Figure 3. The D-1022-S was designed using MacPoisson, a relatively simple Finite Element Analysis code on the Macintosh. The maximum field-enhancement in the connector is about 20%.

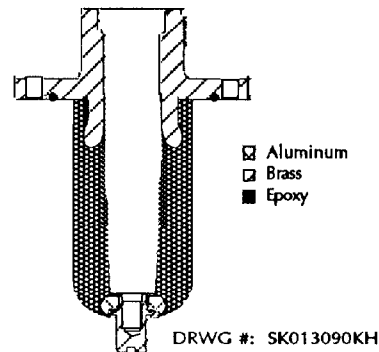

Figure 3. D-1022-S Connector for foil-wrapped RG-220.

The short length of the connector, balanced with the compromise for voltage hold-off capability, serves to preserve the coaxial impedance as much as possible, which can be important for fast pulse systems. The tapered section allows the greased (Dow-Corning 5 Compound) poly section of cable being inserted to force air bubbles out and around the poly. The cable braid is captured inside a SLAC modified UG-156 connector that is threaded onto the D-1022-S. The most probable weak link in this system is the UG-156 connector

section. Also, the eccentricity of the RG-220 type cable is very important for this connector, as is the calibration of the "pencil-sharpener" tool used to taper the poly. SLAC experience has shown that standard RG-220 cable is seldom the same size from batch to batch from most manufacturers, which has led to some problems with cable replacement.

IV. CABLE AND CONNECTOR TESTS

The D-1022-S connector and the associated AA-6778 coax were initially tested on the output of the pulse-charger at voltages between 72 kV to 88 kV for $\approx 10^8$ shots. The output of the cable was unterminated, but a corona [12] ring was installed and the end was mounted in an oil tank. Table 1 summarizes the test results.

Table 1
D-1022-S connector and Times AA-6778
cable slow pulse tests.

Voltage	Rep-Rate	Total Hours
72 kV	60 Hz	18
75 kV	120 Hz	75.16
80 kV	60 Hz	36
80 kV	120 Hz	36
80 kV	180 Hz	69
88 kV	180 Hz	0.0167 *

Max Voltage	Max PRR	HV Hrs	Total Shots	Rise Time	Pulse Width
88 kV	180 Hz	234.18	1.0445×10^8	17 μ s	$\approx 50 \mu$ s

* The pulse charger failed at 88 kV.

The cable connector assemblies were also tested on a 60 Hz AC corona generator [13]. The primary testing was for corona inception voltage. Short lengths of AA-6778 cable were terminated on both ends with the D-1022-S connector, with the end of the connector immersed in oil and terminated with a corona ball of suitable diameter. Corona inception began at about 20.5 kV at the 10 pico-coulomb (pc) level. This agrees well with the MIL C-17 [14] rating of 21 kV of the AA-6778 cable. Raising the voltage to ≈ 22.8 kV, corona activity jumped to the 300 pc level. With a connector from one end of the cable removed, corona inception was at ≈ 18.6 kV. Various mechanical stresses were induced on the cable assembly, after which the inception point dropped to ≈ 13.6 kV. The assemblies also survived high-potting to 100 kV.

The D-1022-S connector was then tested by itself in a fixture designed to eliminate the cable corona from marring the connector corona results. Corona inception of the D-1022-S began at about 37 kV. At 38.6 kV, the level was in the 15 to 20 pc range, and flashover began at nearly 39 kV, which

was most likely the breakdown point of the transformer oil being used in the tests.

V. CONCLUSIONS

The new cable connector assemblies being installed at SLAC will enhance maintainability and reliability. Great care in cable/connector assembly is extremely important for good results. The MIL C-17 specification (under which AA-6778 falls) for HV coax cable appears to be sufficient for SLAC's uses. The D-1022-S/AA-6778 assemblies appear to have a high corona inception point, although more data is required. There are plans to install the D-1022-S connectors between the pulse-charger and the thyatron tank, and to and from the new pulse tuners in series with the 80 ft transmission cables.

Special Thanks to: Don Arnett, Don Williams, John Krzaszczak, Piotr Blum, Raghil Haqq, Jim Cundiff, Clive O'Conner, John Rock, Steve Pearce, and Pat Banglos of SLAC and Joseph Bianco of Isolation Designs, Sunnyvale, CA for their effort in the design, manufacturing, and testing of the described equipment.

VI. REFERENCES

- [1] F Bulos *et al.*, "Some Fast Kicker Magnet Systems at SLAC," in *Proc. of 1987 IEEE Particle Accel. Conf.*, Washington, D.C., March 1987.
- [2] L. Bartelson *et al.*, "Kicker for the SLC Electron Damping Ring," in *Proc. of 1987 IEEE Particle Accel. Conf.*, Washington DC, March 1987, pp. 1582-4.
- [3] T. Mattison *et al.*, "Kicker Systems for the Stanford Linear Collider," in *Particle Accelerators*, vol. 30, pp. 115-20, 1990.
- [4] T. Mattison *et al.*, "Status of the SLC Damping Ring Kicker Systems," these proceedings.
- [5] T. Mattison *et al.*, "Operational Experience with SLC Damping Ring Kicker Magnets," these proceedings.
- [6] G. Gross *et al.*, "Development of Epoxy Potting for High Voltage Insulation at SLAC," these proceedings.
- [7] T. Mattison *et al.*, "Pulse Shape Adjustment for the SLC Damping Ring Kickers," these proceedings.
- [8] R. Cassel and M. Nguyen, "Kicker Pulsed Charger", these proceedings.
- [9] J. Petter, "Improved High Voltage Coax for Antiproton Source Kicker Pulse Forming Networks and Pulse Transmission", Fermi National Accelerator Laboratory.
- [10] C.A. Frost and D.B. Westenhaber, "Effects of Coaxial Cables on Fast-Risetime, High-Voltage Pulses", Joint EMP Technical Meeting, First Annual Nuclear EMP Meeting, 1973.
- [11] W.J. Sarjeant and R.E. Dollinger, "High Power Electronics", Tab Books, Inc, Blue Ridge Summit, PA, pp. 171-180, 1989.
- [12] E. Kuffel and W.S. Zaengl, "High Voltage Engineering", Pergamon Press, NY, NY, pp. 371, 1986.
- [13] R. Bartnikas and E.J. McMahon, "Engineering Dielectrics, Vol. I, Corona Measurement and Interpretation", ASTM STP 669, 1979.
- [14] U.S. Military Specification, MIL-C-17F, January 1983.