

UHV SEAL STUDIES FOR THE ADVANCED PHOTON SOURCE STORAGE RING VACUUM SYSTEM *

J.D. Gonczy, R.J. Ferry, R.C. Niemann, and B. Roop

Argonne National Laboratory
9700 South Cass Avenue
Argonne, Illinois 60439

The submitted manuscript has been authored by a contractor of the U. S. Government under contract No. W-31-109-ENG-38. Accordingly, the U. S. Government retains a nonexclusive, royalty-free license to publish or reproduce the published form of this contribution, or allow others to do so, for U. S. Government purposes.

Abstract

The Advanced Photon Source (APS) Storage Ring Vacuum Chambers (SRVC) are constructed of aluminum. The chamber design incorporates aluminum alloy 2219-T87 Conflat[®] flanges welded to an aluminum alloy 6063-T5 extruded chamber body. Vacuum connections to the aluminum Conflat chamber flanges are by means of 304 stainless steel Conflat flanges. To evaluate the Conflat seal assemblies relative to vacuum bake cycles, a Conflat Bake Test Assembly (CBTA) was constructed, and thermal cycling tests were performed between room temperature and 150°C on both stainless steel to aluminum Conflat assemblies and aluminum to aluminum Conflat assemblies. A Helicoflex[®] Bake Test Assembly (HBTA) was similarly constructed to evaluate Helicoflex seals. Both Conflat and Helicoflex seals were studied in a SRVC Sector String Test arrangement of five SRVC sections. The CBTA, HBTA and SRVC tests and their results are reported.

I. INTRODUCTION

The conceptual design of the APS storage ring vacuum chambers sought to capitalize on emerging technologies coming from Japan, which employed the use of aluminum vacuum chambers, aluminum welding procedures, and aluminum Conflat flanges. The APS accelerator vacuum design constraints require that the hermetic integrity of the UHV seal must be maintained given the following criteria:

Accelerator Life:	Twenty (20) years
Beam-off High Vacuum:	3×10^{-11} Torr
Beam-on High Vacuum:	1×10^{-9} Torr
Pressure Differential:	1-Atmosphere
Thermal Excursion:	20°C - 150°C
Thermal Cycles:	Twenty (20) cycles

Early attempts to achieve regular acceptable performance of the Conflat joints on R&D chamber sections proved troublesome. Also, the manufacturers' recommended practice of assembling joints to a torque rather than registering the flanges was considered to be insufficient to resist side loads and their

[®] Registered trademarks of the Varian Corp., and Helicoflex Co.

* Work supported by U.S. Department of Energy, Office of Basic Energy Sciences under Contract No. W-31-109-ENG-38.

U.S. Government work not protected by U.S. Copyright.

associated possible leaks. However, the recommendations of the manufacturer were followed. The results of the section tests were inconsistent with claims of a problem free UHV seal that can withstand repeated bake cycles to 150°C, with minimal loss of bolt preload, and with no measurable bake-associated axial movement of the flange faces into the gasket.

Testing continued to evaluate the Conflat joint, and in parallel, studies were initiated to investigate the Helicoflex flange and gasket as an alternative to the Conflat assembly.

II. TEST ARRANGEMENTS

The Conflat bake test assembly pictured in Figure 1 was constructed for the purpose of investigating the different vacuum seal geometries that are incorporated in the APS Storage Ring Vacuum System (SRVS) [1]. The CBTA employs 2219-T87 aluminum Conflat flanges welded to a common volume. Ten test flanges make-up the CBTA. Two flanges of each size used on the SRVS (305 mm, 203 mm, 152 mm, 115 mm, and 70 mm) are welded back-to-back across the common volume, thereby providing the CBTA with two identically flanged sides for test. Twenty-three bake cycles were performed in two separate tests that evaluated assemblies using aluminum alloy 1050-H18 and 1050-H24 Conflat gaskets. The H18 assemblies were cycled 13 times to 150°C; the H24 assemblies were cycled 10 times. Table 1 lists the CBTA test configurations.

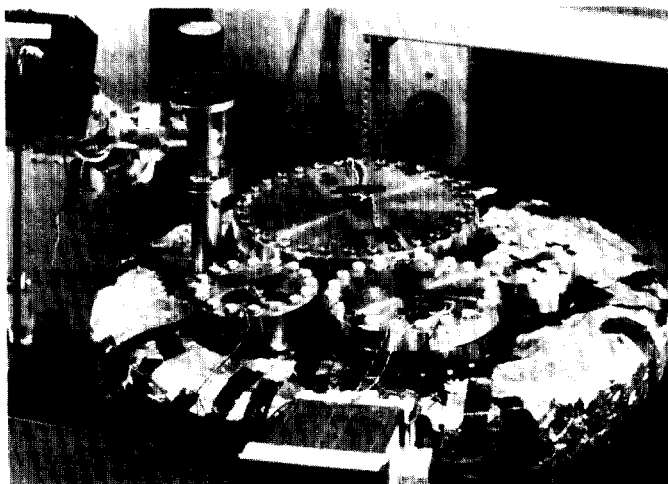
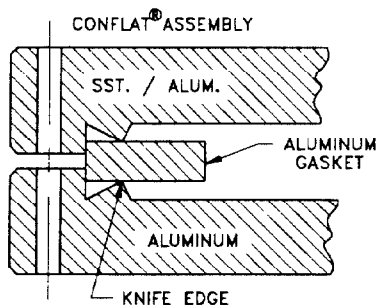

Figure 1. Conflat bake test assembly (CBTA)

Table 1
CBTA test configurations



ASSEMBLY	NON-REGISTERED	REGISTERED	NON-REGISTERED	REGISTERED
COVER FLANGE	ALUMINUM 2219-T87	ALUMINUM 2219-T87	STAINLESS STL. 304	STAINLESS STL. 304
GASKET	H18	1050 ALUMINUM H18	ALUMINUM H24	H24
CHAMBER FLANGE	2219-87 ALUMINUM			
BOLT:	2024-T4 AL	304 SS†	2024-T4 AL	304 SS†
WASHER:	2017-T4 AL	BRASS	2017-T4 AL	BRASS
NUT:	6061-T6 AL	BRASS	6061-T6 AL	BRASS
PREBAKE TORQUE	87 kg•cm	405 Kg•cm	87 Kg•cm	288 Kg•cm
GAP CLOSURE	0.1 mm	N/A	0.06 mm	N/A
POSTBAKE TORQUE LOSS	41-48%	30-40%	30-60%	30-40%

Helicoflex seal tests were done in a Helicoflex bake test assembly (HBTA not shown) using Helicoflex flanges and *delta seal* gaskets. The HBTA test configurations are described in Table 2. The test methodology for the Helicoflex tests was similar to that used for the CBTA tests. All Helicoflex flanges were torqued until the flanges registered. 304 stainless steel bolts were used with brass washers and nut and no lubricant. Ten 150°C bake cycles were conducted.

The SRVS sector string tests continued the Conflat flange testing in an arrangement connecting five R&D sections [2]. The seal configurations, shown in Figure 2, tested Conflat assemblies using aluminum 1050-H24 Conflat seals and Helicoflex *Conflat repair* seals. All of the SRVC flanges are threaded flanges that use M8x1.25 tapped holes. The Conflat flanges that mate to the chamber flanges have through-bolt holes. In one SRVC section, Helicoflex *Conflat repair* gaskets were installed as replacement gaskets for the Conflat aluminum gaskets. The remaining four SRVC sections used standard Conflat aluminum gaskets in the assemblies. The fasteners employed were 2024-T4 aluminum M8x1.25 bolts with a 2017-T3 hard anodized washer beneath the bolt head and molybdenum disulfide as a fastener lubricant. The bolts were torqued to 87 Kg-cm.

Two turbo-molecular pumping stations located at opposite ends of the string test evacuated the test arrangement during bakeout. Multiple bakeout cycles were accomplished by circulating pressurized hot water at 150°C through water channels in the SRVC sections. Following a bakeout, the turbo pumps were isolated. Ion pumps and distributed Non-evaporable Getter (NeG) strips pumped the string test vacuum

during cool down to room temperature. A vacuum of 8×10^{-11} Torr was achieved with two known flange leaks present. UHV was monitored using an extractor gauge. A computerized data acquisition for the SRVS string tests was typical of that used with the CBTA and HBTA tests.

III. TEST RESULTS

Conflat test results show that for Conflat assemblies, which employed stainless fasteners and which registered the mating flanges (flange-to-flange), more bolt torque was required to register the flanges installed with 1050-H18 gaskets than with 1050-H24 aluminum gaskets; 405 Kg-cm as compared to 230 Kg-cm, respectively. At 345 Kg-cm of applied torque, the stress in a 5/16-24 bolt was about 88% of material yield with an elastic stretch totaling 0.12 mm. The post test loss of bolt torque on the H18 and H24 gasket assemblies was approximately the same and ranged from 30 to 40%. No leaks occurred to registered flanges using either seal. Inspection of the aluminum Conflat knife edge at the conclusion of the tests showed no damage to the knife seal edge.

The Conflat flange assemblies that used 2024-T4 aluminum M8x1.25 bolts and were torqued to 87 Kg-cm had a gap remaining between the mating flanges. The preload bolt stress was estimated at 90% of material yield with an elastic bolt stretch totaling 0.15 mm. Measurements after 13 bake cycles found that the gap had closed by about 0.10 mm on all aluminum to aluminum Conflat assemblies that used an H18 gasket. A loss of bolt load was measured as 41 to 48% loss of preload torque. No leaks resulted on any H18 gaskets.

Table 2
HBTA test configurations

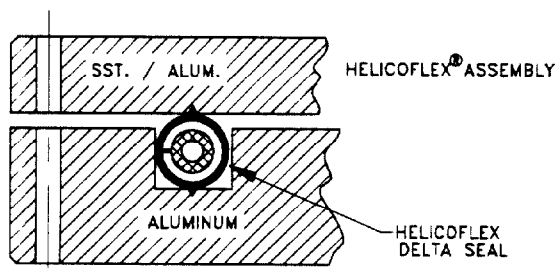

ASSEMBLY	REGISTERED	
FLANGE	ALUMINUM 2219-T87	STAINLESS STL. 304
GASKET	HELICOFLEX DELTA SEAL	
FLANGE	ALUMINUM 2219-T87	ALUMINUM 2219-T87
BOLT:	304 SS†	304 SS†
WASHER:	BRASS	BRASS
NUT:	BRASS	BRASS

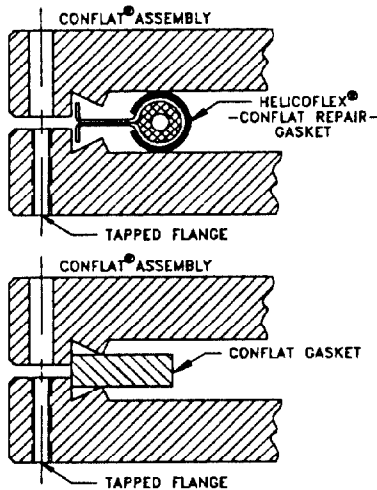

Figure 2. SRVC seal configurations

For stainless steel to aluminum Conflat flange assemblies installed with the H24 gaskets and using aluminum fasteners, the gaps close by approximately 0.06 mm. The gap closure was measured after 10 bake cycles. Loss of preload torque was 30 to 60%. During bake cycle 9, a leak occurred in a 152 mm assembly. Retorquing sealed the leak. The leak reappeared in bake cycle 10, and torquing did not seal the leak.

Helicoflex tests results had two leaks occur during the test. The leaks were attributed to loss of bolt preload. The leaks developed in a 70 mm assembly after 6 bake cycles, and in a 115 mm assembly after 9 bake cycles. Retorquing the bolts to their initial preload value of 345 Kg-cm sealed the leaks.

SRVC sector string test results counted thirty-two vacuum leaks occurring at random during the bake cycle tests. As gaps were present in the assemblies, the Conflat gasket shared the external loads placed on the gaskets from various pieces of vacuum equipment connected to the SRVC flanges. Both Helicoflex and Conflat gaskets developed leaks. The leaks were attributed to fastener loss of preload torque, since all but a few gasket leaks could be sealed by retorquing.

IV. DISCUSSION

Test results from the CBTA, the HBTA, and the SRVC Sector String Tests indicate that many of the vacuum sealing problems that were experienced early with the SRVC's were due to bolting problems, and were not a result of any design fault of the aluminum Conflat joint [3]. The bolting problems originated as a consequence of the early SRVC joint geometry, and attempts to apply the Conflat manufacturer's recommended methods for assembling and torquing the aluminum Conflat flanges to meet the requirements of the SRVC's UHV criteria.

Test findings indicate that aluminum fasteners do not provide enough clamping force to register flanges and to sustain the *long term* UHV seal characteristics required by the APS Storage Ring. This clamping force inadequacy resulted from the early SRVC chamber body flange geometry, and the

foreshortened bolts necessitated by the SRVC use of tapped aluminum chamber flanges. The tapped chamber flanges prompted the use of aluminum fasteners, principally to make use of the low elastic modulus of aluminum and thereby to maximize the stored energy in the short bolts. Lubricants, a potential contaminant to the UHV, became necessary with these fasteners, because aluminum bolt threads on aluminum flange threads require a lubricant to prevent galling or cold welding.

Mechanical and metallurgical analysis of the aluminum gasket during bake cycles supports the findings of a closing gap resulting from annealing and lower modulus at 150°C.

V. CONCLUSIONS

304 stainless Conflat flanges are suitable for all connections to the 2219-T87 aluminum SRVC chamber Conflats.

A through bolt flange geometry is preferred for the Conflat flange assemblies instead of the tapped aluminum flanges that were used on the R&D SRVC sections.

The aluminum alloy 1050-H24 annealed gasket is the preferred gasket for aluminum Conflat assemblies because it requires less torque at installation to register the flanges.

A fastener system without lubricant, e.g., a 304 stainless steel bolt with brass nut and washer was used successfully. Other possibilities for the nut and washer are aluminum-bronze, phosphor-bronze, silicon-bronze or beryllium-copper.

Registration of Conflat assemblies (flange-to-flange) is the preferred method of assembly for aluminum gasket joints; Conflat knife edges are not damaged; external loads are shared by the bolts and flanges and not by the gasket; over-torque of bolts can be employed at flange assembly to augment the clamp force and reduce bolt preload loss.

The Helicoflex conflat repair gasket was used effectively in SRVC Conflat flange assemblies as a substitute UHV gasket for the Conflat aluminum gasket. The Helicoflex repair gasket uses a sealing surface away from the Conflat knife edge and therefore, is unaffected by damage to the Conflat knife seal.

VI. ACKNOWLEDGEMENTS

The authors extend their appreciation to Messrs Richard Ferry, Kevin Haggerty, Richard Prien, Edward Wallace, Dean Wincott and to Lester Erwin and Dan Haid for their effort throughout these tests.

VII. REFERENCES

- [1] G.A. Goepfner, "APS Storage Ring Vacuum Chamber Fabrication", presented at the Top. Conf. of the Vacuum Design of Synchrotron Light Sources Conference, ANL, Argonne, IL, Nov. 1990, (to be published).
- [2] R.C. Niemann, et. al, "APS Storage Ring Vacuum System Development", presented at this conference.
- [3] John H. Bickford, *An Introduction to the Design and Behavior of Bolted Joints, Second Edition Revised and Expanded*, Marcel Dekker, Inc., New York, 1990.