

Laser Cooling of Stored Beams in ASTRID

J.S. Hangst¹, K. Berg-Sørensen, P.S. Jessen, M. Kristensen, K. Mølmer, J.S. Nielsen, O. Poulsen, J.P. Schiffer² and P. Shi
Institute of Physics, University of Aarhus
DK-8000 Aarhus C, Denmark

Abstract

We report the results of laser cooling experiments on 100 keV Li^+ beams in the storage ring ASTRID. The metastable fraction of the lithium beam has been laser cooled to a momentum spread $dp/p \sim 10^{-6}$, corresponding to a rest frame temperature $T_{\parallel} = 1$ mK. Laser diagnostic methods have been employed to study the dynamics of intrabeam relaxation. A theoretical model of laser cooling has been used to interpret the experimental results. We also discuss Molecular Dynamics simulations of intrabeam interactions and the connection with crystalline beams.

I. INTRODUCTION

Laser cooling [1] is the result of the velocity-selective transfer of photon momentum from a laser beam to a moving atom or ion. In the most basic laser cooling scheme, particles having a closed transition between two energy levels are utilized. Those particles which are in resonance with a laser beam absorb photons. Each photon transfers momentum of magnitude $h\nu/c$ to the absorbing particle, which recoils in the direction of the laser propagation. The photons are spontaneously reemitted. The average momentum transfer from the reemission vanishes due to symmetry. The net force is thus directed along the laser beam. The force is velocity selective because of the narrow width of the atomic transition, and velocity dependent through the Doppler effect. By tuning the frequencies of co- and counterpropagating lasers to accelerate slow particles and decelerate fast ones, one achieves cooling. The cooling limit, called the Doppler cooling limit, is given by $k_B T \sim h\Gamma/2$, where Γ is the homogeneous width of the cooling transition. Other schemes have been developed to cool particles to temperatures below the Doppler limit, but these will not concern us here. (See Reference [2] for an overview of lasercooling theory and experiment.)

The use of lasers for cooling ions or atoms stored in traps is well-documented [2]. More recently, it has become possible to cool energetic beams of ions circulating in storage rings. Unlike the trap experiments, which use up to six laser beams to cool all three spatial dimensions, storage ring laser cooling operates only on the longitudinal degree of freedom. In the first reported experiment, a beam of ${}^7\text{Li}^+$ ions with kinetic energy of 13 MeV was laser cooled to a longitudinal temperature of less than 3K [3].

In addition to offering the potential for cooling to very low temperatures, the laser is a unique diagnostic tool. By measuring the laser-induced fluorescence (LIF) of a beam as a function of laser frequency, one can directly and nondestructively measure the velocity distribution of the circulating ions. Unlike electronic means to measure charge density fluctuations in the circulating beam (Schottky signals), the laser is insensitive to collective behaviour in the beam, which can render electronic signals very difficult to interpret.

In the current set of experiments, we have used the storage ring ASTRID to investigate laser cooling and diagnostics of 100 keV ${}^7\text{Li}^+$ ions. We also discuss briefly recent experiments using ${}^{166}\text{Er}^+$. Finally, we comment on the implications our experiments contain for the effort to achieve ordered or "crystalline" beams [4].

II. EXPERIMENTAL APPARATUS

The storage ring ASTRID and its associated optical experimental apparatus are shown schematically in Figure 1. ASTRID has been designed to function both as an ion storage ring and as a source of

synchrotron radiation [5]. For the current studies the machine has been operated as a fixed-energy storage ring for 100 KeV ions. The ring has four-fold symmetry, with four quadrupoles in each straight section. Bending is accomplished by 4 pairs of dipole magnets. Windows at the ends of two straight sections allow laser light to pass into the vacuum chamber. The ring circumference is 40 meters.

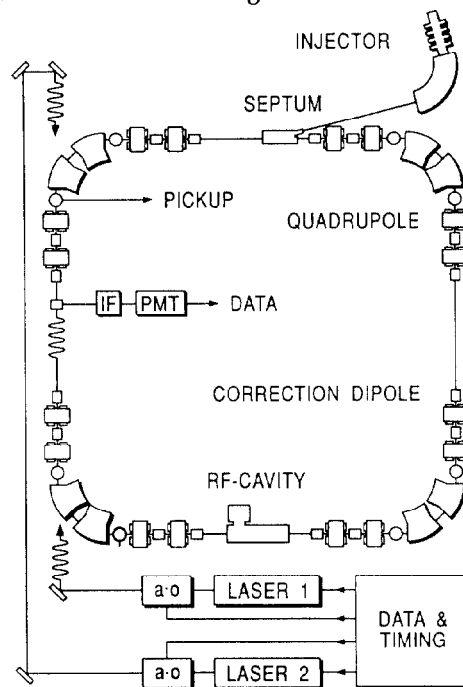

Figure 1. Schematic of the ASTRID storage ring and associated laser apparatus.

A variety of ion sources can be used with the electrostatic accelerator, which has a maximum energy of 200 keV. Ions travel from the accelerator through a mass-separating magnet, and are injected into the ring by a magnetic septum and a fast electrostatic kicker. Sixteen beam position monitors and sixteen correction dipole magnets provide orbit measurement and control. Additional beam diagnostics are provided by a longitudinal Schottky pickup. A radiofrequency cavity is available for bunching and accelerating the ions.

Laser light is provided by two ring-dye lasers, which can be intensity modulated using acousto-optic modulators. Fluorescent light from the ions is monitored through an additional window which looks transversely at the beam. A telescope collects light and directs it to a photomultiplier tube (PMT). An interference filter (IF) of bandwidth 0.6 nm (FWHM) discriminates between fluorescent light (which is Doppler-shifted relative to the direct laser light) and scattered light. The lithium experiments employed lasers and diagnostics in one straight section of the ring. In the erbium case, two straight sections have been used. A spectrometer replaces the interference filter in the second straight section.

III. EXPERIMENTAL PARAMETERS

The 100 keV lithium ion beam utilized is actually a two-component beam. A fraction of the beam ($\sim 10^{-4}$) is produced in the meta-

¹also FNAL, ANL, and Univ. of Chicago

²also ANL and Univ. of Chicago

stable $1s2s^3S_1$ state; the remainder exists in the ground state. The metastable state is connected to the $1s2p^3P_2$ state by allowed optical transitions, and is subject to laser cooling by virtue of a closed hyperfine transition ($F'=5/2 - F'=7/2$). The rest frame wavelength of the transition is about 548.6 nm. The natural linewidth of the transition is $\Gamma=3.7$ MHz, corresponding to a lifetime of 43 ns. This implies a Doppler cooling limit of about 89 μ K. The branching ratio to the ground state is less than 10^{-5} .

After acceleration, the beam has a flattened velocity distribution. The initial longitudinal energy spread is ~ 1 eV, corresponding to $T \sim 100$ mK or $\delta p/p \sim 10^{-5}$. The initial transverse temperature is about 1000 K. Typical beam currents are ~ 10 μ A, corresponding to roughly 10^9 particles injected. The average beam radius, measured by scanning a slit across the LIF image of the beam, was $r_{\text{rms}} \sim 3$ mm. This yields a particle density of about $10^6/\text{cm}^3$. The average pressure in the ring during the experiments was 3×10^{-11} torr.

The erbium ion beam offers the potential for cooling the entire beam population. The cooling transition, of wavelength 541.6 nm, is between the ground state ($J=13/2$) and an excited state ($J=15/2$) at 18463 cm^{-1} . The lifetime of the excited state has not been accurately measured, but is of order 1 μ s. The corresponding Doppler cooling limit is about 4 μ K. Beam currents achieved from the ion source are typically a few microamps. The initial temperatures and densities of the beam from the accelerator are roughly the same as those of the lithium beam.

IV. LASER DIAGNOSTICS - BEAM RELAXATION

The laser has been used as a probe to monitor the longitudinal velocity distribution of the circulating beam. Figure 2 shows the time development of the longitudinal temperature of the metastable lithium ions. In 30 μ s the beam heats from ~ 100 mK to ~ 2 K. At this point the velocity distribution is measured to be thermal with a FWHM of 100 m/s. The temperature continues to increase out to ~ 200 ms after injection, which was the latest time measurable with our experimental setup.

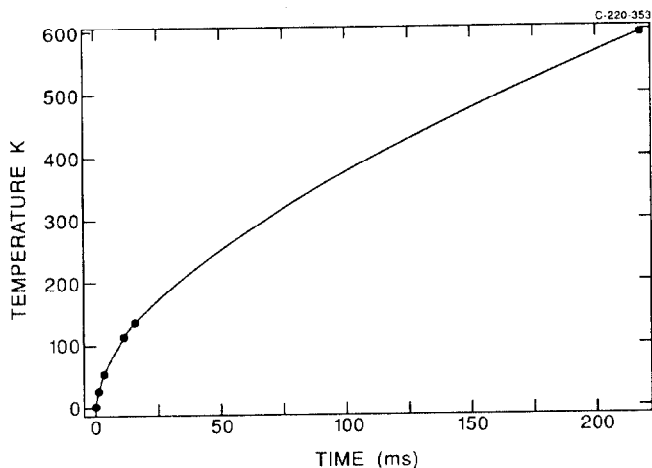

Figure 2. Longitudinal temperature vs. time after injection for $^7\text{Li}^+$ beam.

This observed rapid longitudinal heating may be due to intrabeam Coulomb interactions. Such interactions can transfer momentum from the transverse degrees of freedom to the longitudinal one. The high transverse kinetic energy of the beam particles is a likely source of heating for a beam of the relatively high charge density found in ASTRID. To estimate the importance of this process, we have employed a binary collision description of intrabeam scattering due to Sorensen [6]. The model calculates the energy transfer rate from transverse to longitudinal motion for a beam with an

initially anisotropic velocity distribution ($T_{\perp} \gg T_{\parallel}$). The measured beam size is first used to estimate the transverse energy of the beam. For ASTRID, the contribution of the space-charge force to the beam size is not negligible. The Sorensen description predicts an energy transfer rate of ~ 2 eV/s for the ASTRID beam at the time of injection. This is in good agreement with the initial slope of Figure 2, which gives 1.4 ± 1 eV/s. The shape of the curve in Figure 2 agrees qualitatively with the analytical predictions. A detailed comparison would require measurement of the transverse beam size as a function of time. This has not yet been undertaken.

The method of Molecular Dynamics [7] has also been applied to the problem of transverse to longitudinal energy transfer. The calculation starts with a system which has high kinetic energy in all three dimensions. When the system has equilibrated, the longitudinal motion is stopped. Following the reheating of the longitudinal degree of freedom is then analogous to the experiment represented in Figure 2. Computer size limitations prohibit simulating the actual particle density and transverse temperature corresponding to 10^9 particles in ASTRID. The calculations can, however, be employed to check the scaling relationships of the analytical model. For a system equivalent to 10^7 particles in ASTRID with transverse energies 0.3 to 2 meV, we obtain good agreement with the Sorensen method.

We have recently begun experiments with $^{166}\text{Er}^+$ ions. The laser measurement of the longitudinal heating of the erbium beam is shown in Figure 3. Improvements to our experimental set-up have permitted measurements to be carried out at later times after injection. The erbium curve is clearly richer in structure than that of lithium, with at least two different mechanisms providing time scales for heating. Detailed analysis of these data has just begun. In the erbium case, laser velocity distributions can be compared to measurements of the longitudinal Schottky spectrum. We note here only that the Schottky spectra show strong coherent behaviour of the injected beam for the time scale 0 - ~ 2 s after injection.

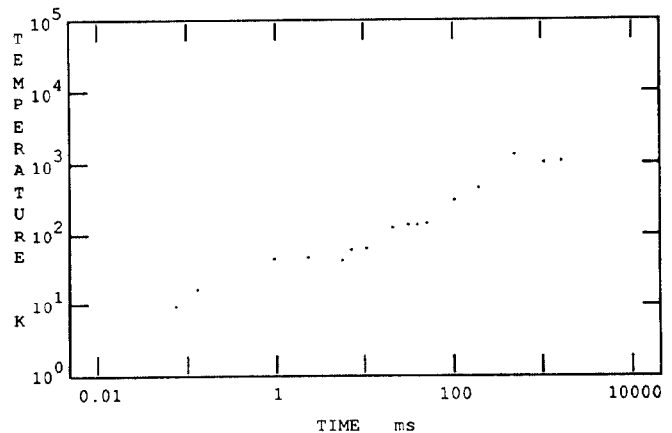

Figure 3. Longitudinal temperature vs. time after injection for $^{166}\text{Er}^+$ beam.

V. LASER COOLING OF METASTABLE LITHIUM

A. Fluorescence signal during the cooling process.

Laser cooling of the metastable fraction of the lithium beam is achieved using two lasers. The co- and counterpropagating laser beams are carefully aligned to achieve maximum overlap with the circulating ions. At the time of injection, both lasers are on, with the copropagating laser initially in resonance with the slower ions. The counterpropagating laser is likewise initially in resonance with the faster ions. After injection, the frequency of the counterpropagating laser is swept towards higher frequencies. The light pressure force from the swept laser decelerates the ions to the velocities in resonance

with the fixed-frequency laser, thereby reducing the velocity spread in the beam. Figure 4 shows the fluorescent light produced in this process, plotted as a function of the frequency of the swept laser. This "cooling spectrum" is accumulated over many injection cycles of the machine in order to obtain good statistics.

The spectrum in Figure 4 exhibits some striking features. The sharp peak at the right side represents the fluorescence from the cooled velocity distribution as the swept laser decelerates the particles across the fixed laser. The detailed analysis of the cooling process, and determination of the temperature, appear below. The strong initial fluorescence, terminated by a sharp drop approximately 1 s after injection, is difficult to account for. The longitudinal heating of the beam due to Coulomb scattering contributes to the rapid onset of the fluorescence, as the tails of the velocity distribution come into resonance with the lasers after about 10 ms. However, the measured heating rate would predict a smoother rise in fluorescence, and the rapid drop in signal after 1 s is not accounted for by this mechanism.

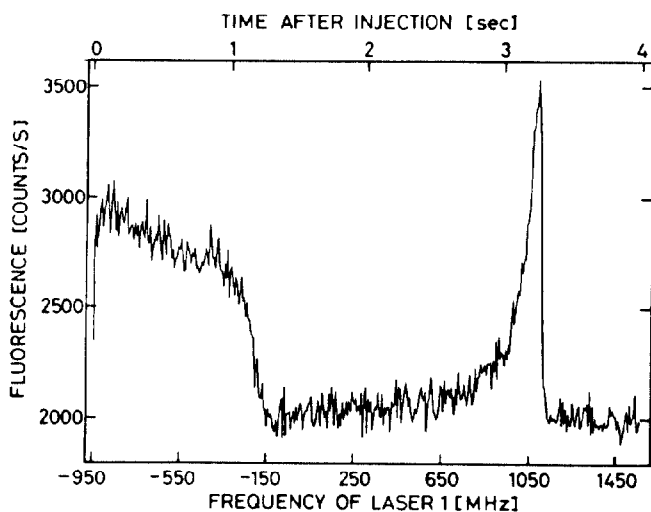

Figure 4. Fluorescence vs. laser frequency for the laser cooling process in ${}^7\text{Li}^+$.

The position of the rapid drop in the signal has been determined to be independent of the intensity, scanning rate, and detunings of the lasers. In addition, it is impossible to produce the cold distribution, identified by the sharp fluorescence peak, before the initial fluorescence has dropped off. These observations appear to indicate that whatever forces are active in the beam at early times cannot be overcome by the laser cooling force. Without any competing heating mechanisms, the laser should be able to cool the metastable fraction to the Doppler limit in only 10 ms.

B. Measurement of the temperature

In order to measure the temperature of the cooled distribution, we use one laser as a probe. The intensity of the laser is lowered to minimize its perturbative effect on the velocity profile. Probe laser powers in the range of 10 to 100 times the saturation intensity of the transition were employed. We find that, for all powers used, the measured width of the distribution is equivalent to that one would expect from power broadening alone. Using the systematic errors in measuring the laser intensity and laser beam profile and the statistical errors, we can put an upper limit on the residual width due to Doppler (i.e. thermal) broadening. We obtain $T_i \sim 1$ mK.

C. Calculation of the temperature

The velocity distribution of the cooled ions can be calculated from the velocity-dependent laser-induced force and diffusion. In the following we neglect intrabeam and other forces not related to the

light force. We assume that at any instant the velocity distribution is stationary and determined by the actual laser field parameters. This assumption is supported by the experimental observation that, after the initial drop in fluorescence, the effectiveness of the cooling process is independent of the speed with which the frequency of the cooling laser is swept.

The velocity-dependent force is calculated by the continued fraction method [7]. The fluctuations in the light-induced force are described by a diffusion coefficient, derived using a procedure due to Minogin [8]. The velocity distribution for a given field configuration is obtained as a stationary solution to the Fokker-Planck equation. For the laser intensities and polarizations used in the ASTRID experiments, we obtain a minimum temperature of $T_{\text{min}} = 1$ mK.

VI. CONCLUSIONS — LASER COOLING AND CONDENSED BEAMS

At the low temperatures attainable with laser cooling, the potential to achieve spatial ordering of the beam [9] exists. For ASTRID, Molecular Dynamics simulations predict that 10^7 particles should condense into three coaxial shells [10]. Similarly, 10^9 particles would form about 30 shells. The threshold for the transition from a one dimensional ordered string to a structure having transverse extent is about 10^6 particles. Of course, to achieve order, the beam must be cold in all three degrees of freedom. The metastable fraction of the lithium beam amounts to about 10^5 particles, which is below the string threshold. The influence of the ground state ions, which are not subject to the laser cooling force, cannot be overlooked. It is difficult to imagine an ordered state coexisting with the warm ground state ions.

Also pertinent to the effort to obtain an ordered beam is our observation of strong forces which compete with the laser cooling process. The ability to laser cool the lithium ions is strictly correlated with the drop in fluorescence (Figure 4). This may indicate that a threshold phenomenon (e.g. a beam instability) is active in the dense ASTRID beam. The inability of the laser to overcome the intrabeam forces may be due to the short range of the cooling force. The laser interacts only with those particles whose velocities lie within the power-broadened linewidth of the cooling transition. The vast majority of the particles are free to diffuse under the influence of other forces. The two-component nature of the lithium beam exacerbates this situation, since the ground state ions do not respond to the laser. Our experience suggests that further experimental efforts are necessary in order to understand the mechanisms which limit the effectiveness of the laser cooling force.

REFERENCES

- [1] D.J. Wineland & H. Dehmelt, *Bull. Am. Phys. Soc.*, 20 (1975) 637 & T. Hänch and A. Schawlow, *Optics Comm.* 13 (1975) 68
- [2] S. Chu and C. Weiman, in *J. Opt. Soc. Am.*, B6(1989) 2020
- [3] S. Schröder et al., *Phys. Rev. Lett.* 64, 2901 (1990) & private communication
- [4] J.P. Schiffer and P. Kienle, *Z. Phys.* A321, 181 (1985)
- [5] S.P. Møller, these proceedings
- [6] A.H. Sørensen in *CERN 87-10* (ed. Turner, S.) 135-154 (CERN, Geneva, 1987)
- [7] V.G. Minogin and O.T. Serimaa, *Opt. Comm.* 30, 373 (1979)
- [8] V.G. Minogin, *JETP* 53, 1164 (1981)
- [9] J.P. Schiffer & O. Poulsen, *Europhys. Lett.* 1, 55 (1986)
- [10] A. Rahman and J.P. Schiffer, *Physica Scripta* T22, 133 (1988)