

The CEBAF Frequency Distribution System*

A. Krycuk, J. Fugitt, K. Mahoney, S. Simrock
 Continuous Electron Beam Accelerator Facility
 12000 Jefferson Avenue
 Newport News, VA. 23606

INTRODUCTION

The RF system for the CEBAF accelerator requires that two frequencies, 70.000 and 499.000 MHz, be distributed throughout the accelerator site. Proper operation of the multipass beam requires an energy spread of less than 2.5×10^{-5} . This imposes stringent constraints on the allowed slow phase error, in turn implying that there must be active regulation of the phase of the distributed reference frequencies.

There are several methods already in use that regulate the phase of a distributed signal^[1,2]. A SLAC type pulsed microwave interferometer was not readily applicable, as this method uses the off time in a pulsed accelerator to perform its phase correction and measurement; CEBAF is a continuous device with every RF bucket filled. Since the CEBAF system requires amplifiers in the distribution line, a diplexed reference signal such as that used at LANL would require a series of discrete control loops, tied together with an overall control loop. It was felt that a less complex system would be desirable.

To accomplish this, the frequency distribution system uses temperature regulated coaxial lines to provide high level signals to the RF control modules in the klystron galleries, combined with a lower power reference signal carried via phase stable fibreoptic cable.

MASTER OSCILLATOR

The master oscillator serves as the RF reference source used throughout the accelerator complex. It is composed of an indirect multiple output frequency synthesizer, a 10 MHz reference source, and power conditioning circuitry. Three output frequencies, 70, 499, and 1497 MHz are derived from the 10 MHz reference. Each frequency is synthesized using a multiple phase locked loop architecture.

Reference phase noise is the largest single contributor to uncorrected errors in the accelerating cavity RF control system. As such, it is imperative that the phase noise of the master oscillator be held to as low a value as possible. The phase noise requirements for the master oscillator are given in Table 1.

A unique requirement for the master oscillator is that all frequencies remain in the same, albeit arbitrary, phase relationship for the life of the oscillator. Normally a frequency synthesizer may lock to a modulo pi phase of its reference. If this were true for the CEBAF MO, then each time the system was brought up it could potentially change

the reference phase of the entire accelerator by 180 degrees. A known phase relationship is maintained through the use of subloops which compare the 499 and 70 MHz outputs. The 1497 MHz output is derived by multiplication of the 499 MHz output.

Table 1. SSB Phase Noise of Master Oscillator

OFFSET FROM CARRIER	SSB PHASE NOISE, dBc/Hz		
	70 MHz	499 MHz	1497 MHz
10 Hz	-90	-85	-75
1 kHz	-130	-135	-120
100 kHz	-150	-155	-140

HIGH LEVEL DISTRIBUTION

This portion of the system distributes the two RF reference frequencies to the RF control system and the klystrons themselves (Figure 1). The oscillator output at both frequencies is amplified to +30 dBm and carried via 7/8" foam filled coax to the accelerator service buildings. In the Injector and RF Separator buildings, the 499.000 MHz signal is fed directly to the RF control modules which regulate those subharmonic cavities.

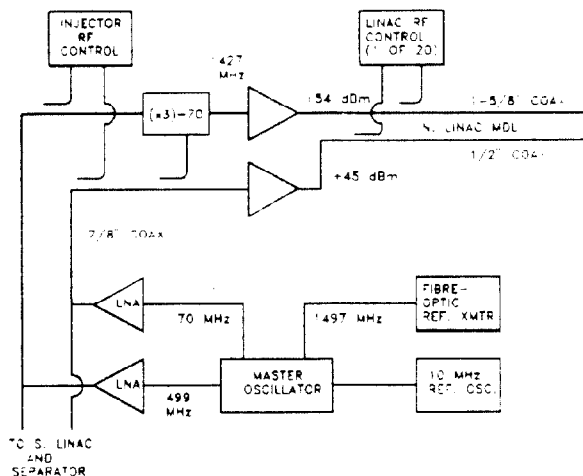

Figure 1. High Level Coaxial Distribution System

The klystrons in the north and south service galleries, however, operate at 1497.000 MHz. The RF controllers for these cavities operate using 70.000 and 1427.000 MHz^[3].

*Supported by D.O.E. contract #DE-AC05-84ER40150

Therefore, prior to distribution to the klystron galleries, the 499.000 MHz signal is multiplied by three and mixed with the 70 MHz signal to obtain 1427.000 MHz. It is this frequency which, along with the 70 MHz, is distributed to the control modules.

MAIN DRIVE LINE

The 1427.000 and 70.000 MHz signals are amplified to +54 and +45 dBm respectively, prior to introduction onto the main drive line (MDL). The MDL consists of a pressurized 1-5/8" rigid coax line and a 1/2" foam filled coax line encased in a temperature regulated jacket (Figure 2). The 1-5/8" coax is used as the transmission medium for the 1427 MHz signal; the 1/2" carries the 70 MHz signal. As the 750 ft. long 1-5/8" coax is phase sensitive to temperature changes (6.5° phase/ $^\circ\text{C}$ @ 1427 MHz), it is imperative to maintain temperature regulation to within $\pm 1^\circ\text{C}$ to meet the required phase stability. The 1-5/8" rigid coax is pressurized to 4 psig with dry nitrogen to provide a desiccating atmosphere and control any change in dielectric length due to pressure variations. A similar effect could have been obtained by evacuating the coax, though this approach is not as attractive in view of the large amount of power lost as heat on the inner conductor which must be removed.

large change in signal level from one end of the klystron gallery to the other. Line loss in the 1-5/8" coax causes a significant decrease in the 1427 MHz signal, from an input of +53 dBm to +40 dBm at the end. In order to maintain the desired coupled value of +30 dBm at each RF module, it is necessary that the coupling value be adjustable. This could also be accomplished by maintaining a constant coupling value with attenuative pads as required, but this would result in the need for an even larger amplifier, with a concomitant increase in cost. In order to isolate the MDL from any microphonic noise, the entire 750 ft. length is suspended from O-rings spaced every 5 feet.

FIBREOPTIC REFERENCE LINE

Whereas the MDL provides the requisite degree of phase stability in the north and south linac galleries, there is no active temperature regulation of the remainder of the coaxial distribution system. Left uncorrected, this could result in the linacs drifting in phase with respect to each other and the rest of the accelerator. To correct for this, an overall phase reference/correction system was designed.

The method used makes use of the inherent phase stability of fibreoptic cable. Sumitomo Corporation has developed an ultra-phase stable fibre that has been tested with great success at KEK and JPL [4,5]. This fibre, run the entire circuit of the CEBAF accelerator, approximately 1.5 km., would exhibit a thermal shift of $.12^\circ$ phase/ $^\circ\text{C}$, as compared to the unregulated coax shift of 5° phase/ $^\circ\text{C}$. A 2 mW laser diode operating at $1.3 \mu\text{m}$ was obtained from BT&D. The diode and its associated receivers are capable of being modulated at 6 GHz, far beyond the needs of CEBAF.

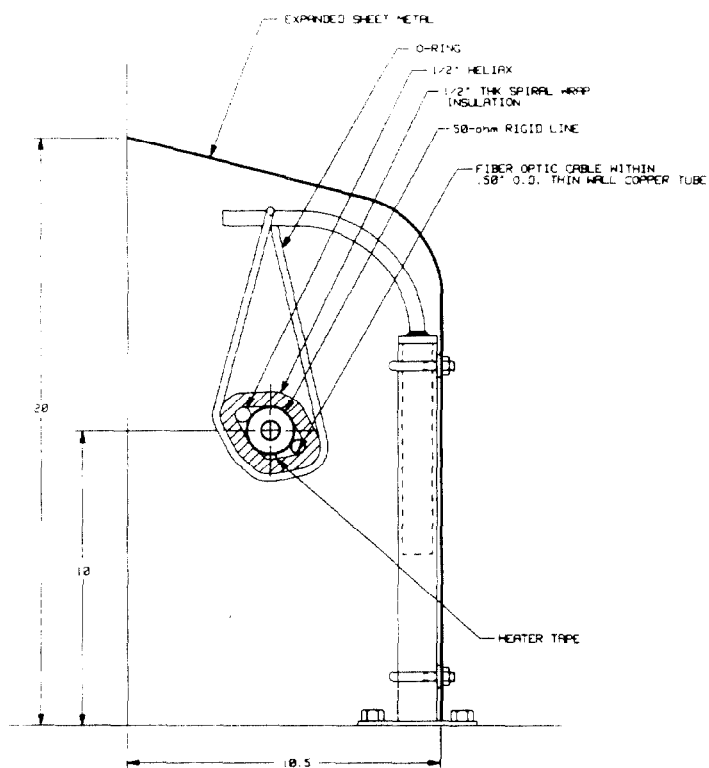

Figure 2. Cross-Section of Main Drive Line

The MDL is fabricated in 10 meter segments, with directional couplers provided for both lines at the end of each section. The 70 MHz (1/2" coax) is fitted with a simple 20 dB coupler, as attenuation does not result in a

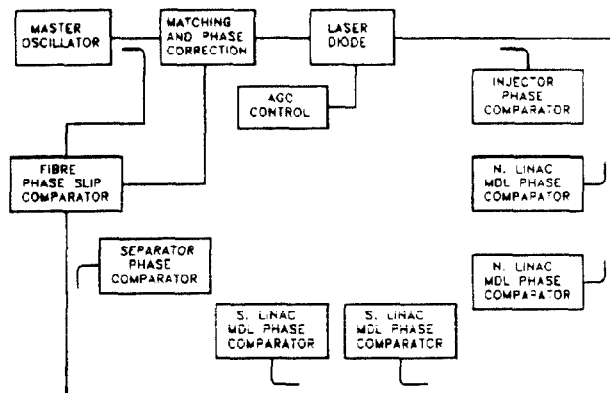

Figure 3. Fibreoptic Reference System

The usual drawback to RF transmission via optical fibre is the high system insertion loss, resulting in a received RF signal which must be amplified 30 or 40 dB to attain its original signal level. Such amplification is not only expensive, but as can be seen in Figure 3, it would be extremely difficult to obtain amplifiers which tracked in phase for each fibreoptic receiver. The source of most of the system insertion loss is the technique used to match the RF source (50 ohm) to the fibre transmitter (7 ohm)

and receiver (high impedance). Normally, a 50 ohm load is placed in parallel with the fibreoptic device. This technique is appropriate for communication systems where the devices must be matched over wide bandwidths. The RF reference system, operating at one frequency, has no such bandwidth requirement. Therefore, a reactive matching network^[6], which trades wide band response for a reduction in narrow band insertion loss, has been incorporated for both the transmitter and receivers.

The fibreoptic signal is coupled off at selected locations throughout the accelerator (injector, beginning and end of north and south linac MDL's, and separator) and compared with a coupled portion of the distributed high level signal. The phase difference between these two is assumed to originate in the drift of the coax system, and an appropriate correction will be applied. In order to correct for any phase slip or change in the fibre itself, the optical cable is routed back to the control room to be compared in phase with the original master oscillator signal.

CURRENT STATUS

The system design has been completed and components are under test. Two 20 ft. sections of 1-5/8" rigid coax have been encased in a prototype thermal jacket regulated by an in-house constructed temperature controller,

with the interior pressure maintained by a commercially-obtained absolute pressure regulator. Preliminary results indicate that temperature regulation to $\pm 1^\circ\text{C}$ is achievable. The laser diode source for the fibreoptic reference system has been characterized and a matching circuit is being fabricated.

REFERENCES

- [1] Schwarz, H. and Weaver, J., "The RF Reference Line for PEP," IEEE NS-26, No. 3, 3956 (1979).
- [2] Jachim, S., Regan, A., Gutscher, D., "A Phase-Stable Transport System," NPB Technical Symposium, May, 1990.
- [3] Simrock, S., "RF Control System for CEBAF," presented at this conference.
- [4] Tanaka, S., Murakami, Y., *et al.*, "Precise Timing Signal Transmission by a New Optical Fiber Cable", KEK Report 90-5, May 1990.
- [5] Primas, L., Lutes, G., Sydnor, R., "Stabilized Fiber-Optic Frequency Distribution System", TDA Progress Report 42-97, vol. January-March 1989, Jet Propulsion Laboratory, Pasadena, California, pp. 88-97.
- [6] de La Chapelle, M., "Computer-Aided Analysis and Design of Microwave Fiber-Optic Links", Microwave Journal, pp. 179-186, September 1989.