

## Upgrade of the Main Ring Magnet Power Supply for the KEK 12GeV Proton Synchrotron

H.SATO, T.SUENO, T.TOYAMA, M.MIKAWA and T.TODA  
National Laboratory for High Energy Physics, 1-1, Oho, Tsukuba-shi, 305, Japan  
and S.MATSUMOTO  
Dokkyo University School of Medicine, Mibu-machi, Tochigi, 321-02, Japan.

### Introduction

In order to use the slow extracted beam of the PS more effectively, the period of slow extraction has been extended. In this paper, upgrade of the main ring magnet power supply will be described. The main power supply consists of thyristor rectifiers, DC filters, reactive power compensators, AC harmonic filters and control systems. To increase the current capacity during flat top, the rectifiers and transformers were improved. AC network and DC filters were remained as it is, since the acceleration and deceleration times were not varied. Analog control devices and the computer control software have also been improved to realize a 2 sec flat top with a 4 sec repetition rate compared with the former 0.6sec flat top with a 2.5 sec repetition rate.

### The magnet power system

The magnet power system consists of magnet power supply (23.6MVA), reactive power compensator systems (20 MVar lag for fundamental) and harmonic filter banks (20 MVar lead). The ring magnet power system has three separated magnet power supplies, one is for the bending magnets and the other two are for the horizontally and vertically focusing quadrupole magnets. The quadrupole magnet currents must be tracked separately to the bending magnet currents for precise tuning of betatron oscillation to perform the optimum beam acceleration.

Desired exciting currents of these magnets are fed by output voltages of power thyristor converters controlled by ignition angles. They are given by analog phase shifters which compare with the reference and the pattern voltages through negative feedback of two loops by a minor automatic voltage regulator (AVR) and by the main automatic current regulator (ACR). These patterns are output to the converters through DAC every 600 Hz synchronized on the six phase ac line by the control computer system.[1] The computer rewrites the control voltage pattern in accordance with measured deviations from the reference current by a repetitive control algorithm.[2] The load parameters of the main magnets and the typical current patterns of the bending magnet are shown in Table 1 and Fig.1, respectively.

In order to suppress the ac line voltage flicker induced by the pulsed lag reactive power of magnet power supply converters, reactive power compensator of thyristor controlled reactor has been equipped of total power of 20MVar.[3] These lag powers are compensated by lead power of the four banks of resonance type harmonic filters [4] (4MVA for third,

4MVA for fifth, 3MVA for seventh and 9MVA for high pass).

The logical ripple components over 300Hz are reduced well by the passive low pass [5] and the dynamic filters.[6] Fig.2 shows a Schematic diagram of the main ring power supply system.

Table 1. The load parameters of the main magnets.

	B Magnets	Q Magnets
Resistance	0.75Ω	0.32Ω
Inductance (at Inj.)	1.1H	0.12H
Time Constant	1.5sec	0.38sec
Injection Current	200A	110A
Flat Top Current	2850A	1600A
Acceleration Time	790msec	
L (dI/dt)	3400V	210V
R x I (at Flat Top)	2100V	510V

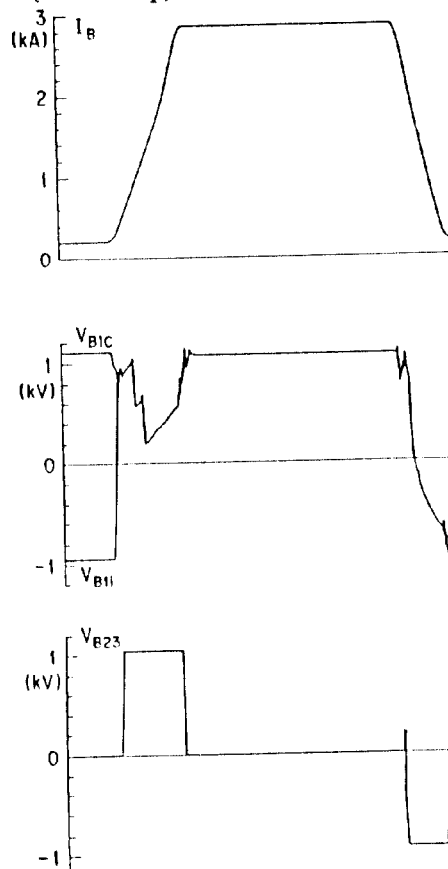

Fig.1 Typical Current and Voltage Patterns of the Bending Magnet at 12 GeV Operation.

Up to bottom; Current, Converter and Inverter Voltage, B23 Converter Voltage.

The bending magnets power supply has consisted of six twelve-pulse rectifiers and controlled by six groups of voltage patterns. Each bridge of the B1 group is fired by a converter-inverter operation in order to reduce the direct current ripple component during injection period and further to reduce the ac line flicker.[7] These patterns are also optimized for reactive power and for voltage ripples to be minimized by controlling by-pass thyristors of four group B23 converters. These voltage patterns are also shown in Fig.1.

To increase the current capacity of the B1 group rectifier, B0 is connected in parallel with B1 via interphase reactors and controlled by the same voltage pattern as B1. The transformer banks are connected with 15degree difference resulting in a 24-pulse rectifier. Each bridge of them is also fired by a converter-inverter operation. An allowable current deviation in the interphase reactors between B0 and B1 is designed to be 15%, then the feedback control system as shown in Fig.3 is used to decrease the imbalance current between transformers.

To increase the current capacity of the B23 converters during the by-pass period, new thyristor switches are connected in parallel with the former by-pass thyristor.

Each of the quadrupole magnet power supplies have been controlled by group of the pattern and have been fed by two power transformers.

Fig. 4 gives a schematic block diagram of the hybrid control system. The analog system covers the ACR and AVR loop as a real-time negative feed back control to thyristor switching. The control voltage is a sum of the pattern signals AVR and ACR. By a 16-bit DAC, the pattern voltages and current are given for every 12-pulsed thyristor group at the 600 Hz control clock synchronized to the ac-line voltage.

The control computer system consists of the main cpu system HIDIC-V90/25 and input and output controllers HISEC-04M.[8] These control computer systems and operation terminal in the accelerator central control room of are connected by a local area network.

The bending magnet power supply is controlled by six voltage patterns for thyristor converter groups and by the current pattern for the ACR. The quadrupole magnet power supplies also work by the reference voltage to the thyristor group and by the current pattern. These patterns are fed through 16-bit DAC sets by the output controller H-04M.

The input controller as the detector system H-04M logs magnet currents from DCCT and voltages through the sets of 16-bit ADCs at every 600Hz control clock cycle.

For extension of the flat top period, memory and hard disc capacity was increased and reproduce an application soft ware. If the operation will be performed with the long flat top pattern, the control clock is synchronized with 300Hz to save the memory.

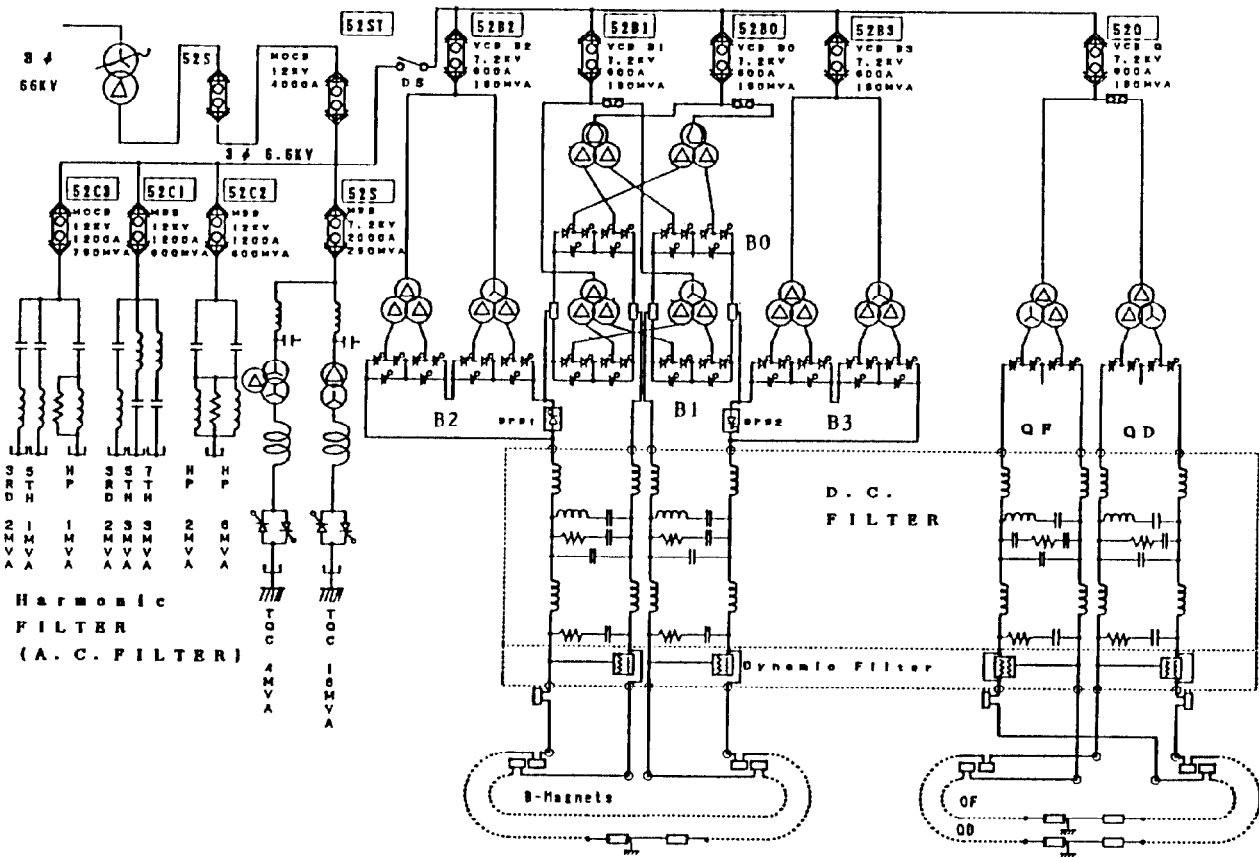

Fig.2 Schematic Diagram of the KEK 12GeV PS Main Ring Power Supply

## Results

The magnet power system of the KEK 12 GeV PS was upgraded to expand the flat top. The current capacity of bending magnets power supply has increased. The analogue and computer control system have been also reconstructed. Eight twelve-pulse rectifiers for the bending magnets are still controlled by six groups of voltage patterns. The hybrid control system with the analog ACR and AVR loop as real-time negative feedback control and the repetitive current and voltage control have been performed.

## Acknowledgments

The authors would like to express their sincere thanks Prof. Michio Nakano (Tokyo Inst. Tech.) for his discussions and much advice on the control system. They also express their thanks to Prof. M. Kihara, who is the director of PS division, for his advice and support. They are much indebted to many colleagues of the PS division for their discussions and collaborations.

## References

- [1] T.Sueno, M.Toda, S.Matsumoto and K.Mikawa, "Software Systems of the Main Ring Magnet Power Supply for the 12 GeV PS," Proceedings of the 6th Symp. on Acc. and Tech., 1987, Tokyo, Japan, pp.155.
- [2] S.Matsumoto, T.Sueno, K.Mikawa and N.Kumagai, "Control of the Main Ring Magnet Power Supply for the 12 GeV PS," Proceedings of the 6th Symp. on Acc. and Tech., 1987, Tokyo, Japan, pp.158.
- [3] S.Matsumoto, H.Baba, H.Sato, T.Sueno and K.Mikawa, "Improved Control System of the Thyristor Flicker Suppressor For the KEK 12GeV PS," IEEE Transactions on Nuclear Science, NS30(1983)2932
- [4] T.Shintomi, M.Masuda and S.Matsumoto, "Harmonic Current AC Filters at a Large Accelerator," Particle Acc8(1978)87
- [5] H.Sato, "Passive Low Pass Filter for the Large Power Device," KEK Internal ASN-277(1987) in Japanese
- [6] H.Baba, H.Sato, S.Matsumoto, T.Kubo, K.Kitagawa, K.Asaji and A.Kabe, "Improved Dynamic Filters for the Main Ring Magnet Power Supply of the KEK 12 GeV PS," IEEE Transactions on Nuclear Science, NS28(1981)3068
- [7] T.Shintomi and M.Masuda, "The Converter-Inverter Operation of the Power Supply for the KEK Proton Synchrotron," KEK-74-2.
- [8] S.Matsumoto, T.Sueno, K.Mikawa, M.Toda and H.Baba, "New Multi-Microprocessor Control System of the Main Ring Magnet Power Supply for the KEK 12 GeV PS," Proceedings of the 1987 IEEE Particle Accelerator Conference, 1987, Washington D.C., pp.689.

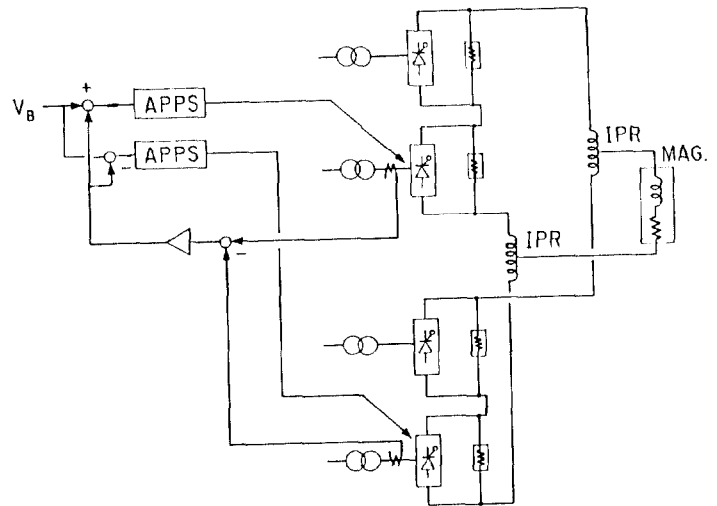

Fig.3 Feedback control of the primary transformer current deviation.

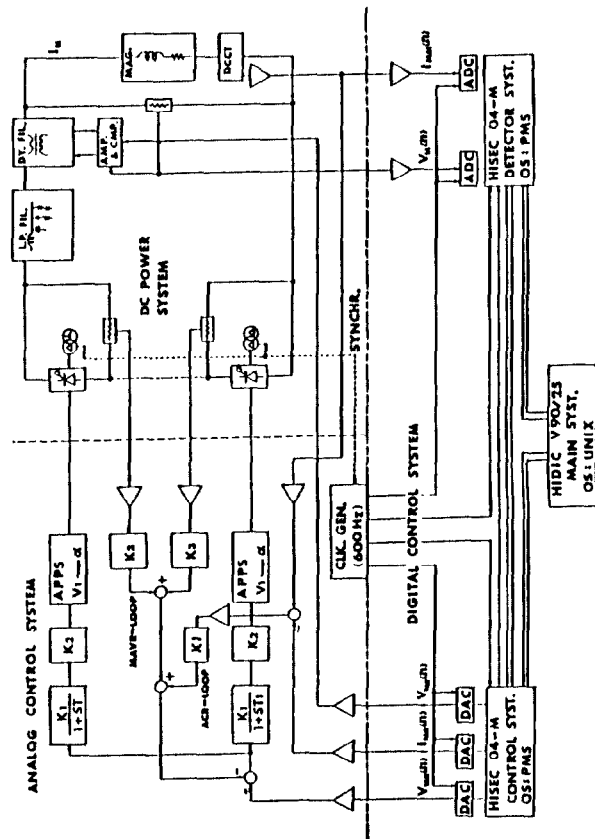

Fig.4 Schematic Block Diagram of the Hybrid Control System.