

## TRAINING OF LBL-SSC MODEL DIPOLE MAGNETS AT 1.8K\*

W.S. Gilbert, R. Althaus, R. Benjegerdes, S. Caspi, C. Peters, J. Rechen, J. Royet, R. Scanlan, C. Taylor, A. Wandesforde, and J. Zbasnik

Lawrence Berkeley Laboratory  
University of California  
Berkeley, CA 94720 USA

### Abstract

We present the 1.8K training behavior of SSC Magnets, several of which have reached a peak current of 9400 A; a central field of 9 Tesla. For the SSC Project, more than 30 one meter long dipole magnets have been built and tested. The test results for the 4.3K operation have been presented previously. Magnet operation, primarily reaching design field without premature training, is expected to be superior in superfluid helium at 1.8K as compared with helium I at 4.3K. Not only is the critical current increased at the lower temperature, but the heat transfer is much improved. LBL has had an operating helium II facility for nine years<sup>(1)</sup> and our standard test sequence has been to check for training in helium I at 4.3K and then cool the system down to 1.8K and train the magnet to its new, high limit. Because the mechanical forces are much greater at the higher currents and fields achieved at the lower temperature, information has been obtained on the adequacy of the mechanical design. Even for those magnets in which training quenches occurred in the inner layer at 4.3K, many of the quenches at 1.8K occurred in the outer layer.

### Introduction

Enhanced, higher field, operation of NbTi magnets is expected in 1.8K He II as compared with 4.3K He I. The material critical current density is increased at the lower temperature<sup>(2,3)</sup> and the cooling is greatly enhanced in superfluid helium<sup>(4,5,6,7)</sup>. These expectations have been tested in a number of LBL-SSC dipole models<sup>(8)</sup> over the past five years.

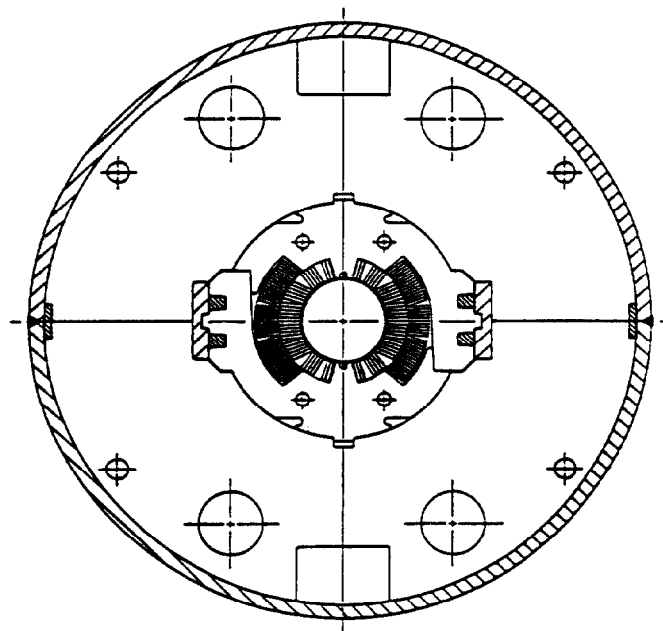

Fig. 1 Cross Section Dipole Magnet

### Mechanical and Magnetic Details

Figure 1 is a cross section of the SSC magnet with an aluminum collar system enclosing the two layer coil. The coil is graded with the outer layer, which is in a lower field, having thinner cable and operating at a higher current density. The outer layer is designed to have about a three percent current margin when the inner layer is at its short sample limit, both at 4.2K and 1.8K. These magnets are designed to minimize structural material because of the vast scale of the SSC and so training due to small motions often occurs below the short sample limit. Identification and improvement of these structural weaknesses is the prime purpose of the R&D program and a major tool is the improvement in the magnets' training curves. In the SSC magnet, the iron outside the collar is contained in a stainless steel shell which is welded. In the LBL test magnets, the shell is not welded but is held in heavy stainless steel clamps that allows us to experiment with various clamping schemes - see Figure 2.

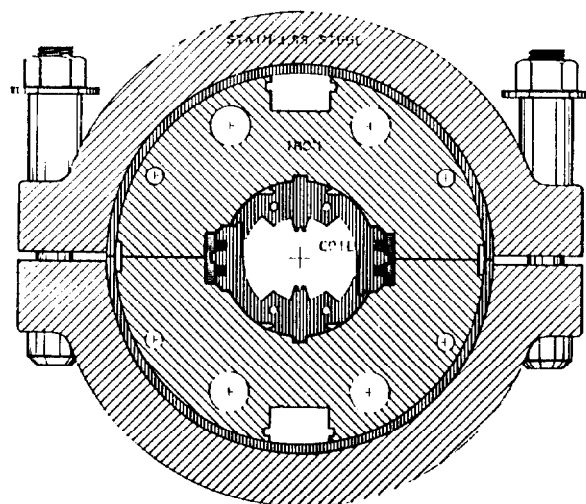

Fig. 2 Stainless Steel Iron Clamp

In Figure 3 are displayed the peak magnetic field in the inner layer and the short sample curves at 4.2K and 1.8K. The central dipole field is about five percent lower than the peak field. As one can see the intersections occur at 7200 A at 4.2K, or 7.1 tesla and at 7900 A at 1.8K, or about 9.2 tesla.

The Lorentz force on the coil scales approximately as  $B^2$  so one has, at short sample, increased the coil loading by  $92/72 \approx 1.7$ . This higher electromagnetic loading enables us to probe more deeply for mechanical motions and other causes of magnet training.

\* Work supported by the Director, Office of Energy Research, Office of High Energy and Nuclear Physics, High Energy Physics Division, U.S. D.O.E., under Contract No. DE-AC03-76SF00098.

INNER LAYER D-15B-1  
SHORT SAMPLE & LOAD LINE

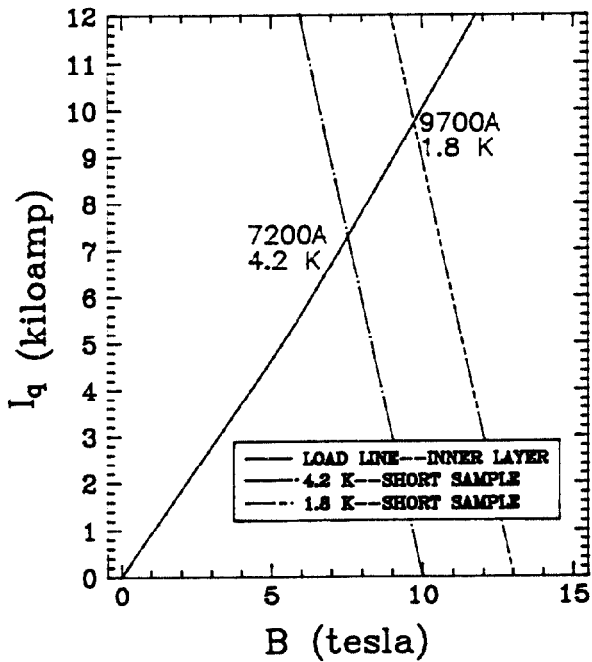

Fig. 3 Magnet Temperature Effects

TRAINING OF D-15B-1  
LBL-SSC DIPOLE MODEL

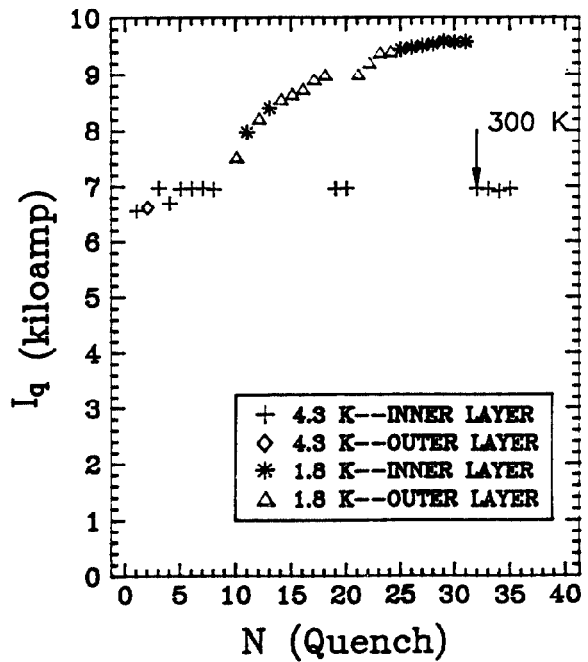

Fig 5 Slow Training in He II

Training in He II

In Figures 4 and 5, we show the complete training curves of two excellent magnets. Figure 4 shows extremely fast training in He II; remember that the mechanical design was optimized for He I operation. Figure 5 shows slow but successful training in He II.

TRAINING OF D-15A-3  
LBL-SSC DIPOLE MODEL

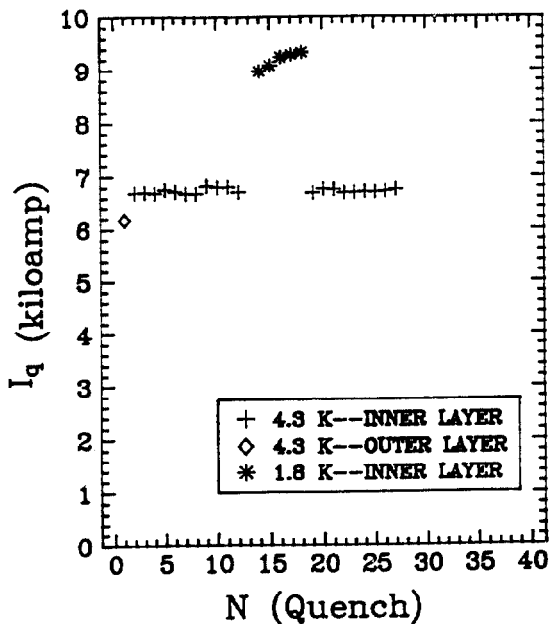

Fig 4 Fast Training in He II

D-15A-4F TRAINING D-15A-4FR1  
LBL-SSC DIPOLE MODELS

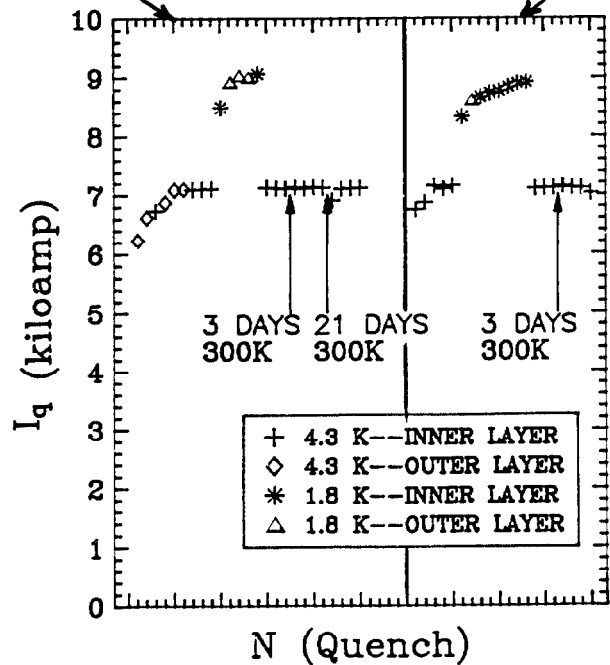

Fig 6 Improved Training with IRON CLAMPING

The magnet of Figure 6 originally did not have quite as good a 4.3K training history as the magnets in Figures 4 and 5. The clamping system of Figure 2 was modified so that the return iron pressed on the outside of the aluminum collar. Previously it only touched on the sides. The right hand side of Figure 6 shows that the training at 4.3K was improved so that the first quench was above the 6.6 tesla operating level of the SSC. Additionally, the quenches occurred in the inner layer where previously some of the quenches occurred in the other layer.

### Low Temperature Conditioning

The premature quenching of small filament, high current density, coils is associated with small wire movements. The accepted mechanism is Lorentz Forces moving the coil elements as little as a few micrometers and releasing, against friction, energies as low as a few millijoules. Still this can be enough to drive these conductors normal when they are near their critical surface. After they have moved, they will not move until a higher current and greater force is achieved.

If one lowers the bath temperature to the superfield range of 1.8K, one can ride out the small heat releases associated with wire movements as the magnet is energized to its operating field. In He I at 4.3K, often several quenches are needed to train the magnet above the desired 6600 A operating level. In He II at 1.8K, we ramped several magnets to 7200 A without quenching. Then we warmed them to He I at 4.3K and quenched them, now well above the 6600A level or at their short sample limit. This is in Figure 7. We call this low temperature, non-quench training, "conditioning" (9,10).

### TRAINING LBL-SSC DIPOLE MODELS (Tests in He I at 4.4 K)

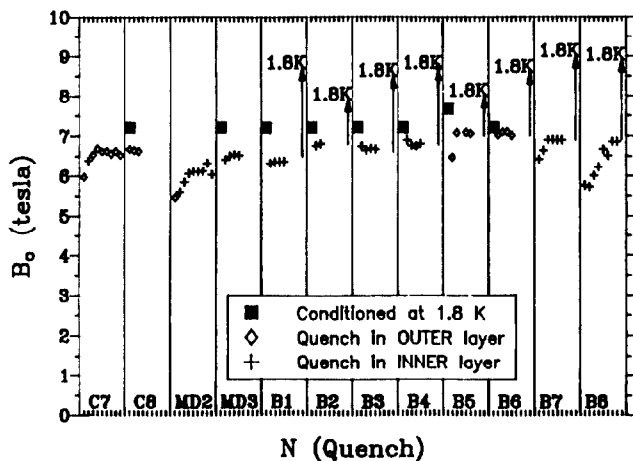

Fig. 7 Low Temperature Conditioning

### Recent Magnet Tests

Lessons learned from the above have been incorporated in recent magnets with the He I 4.3K training results shown in Figure 8. Several magnets operate at or above the 6.6 tesla SSC operating level on their first quench and additional progress in reducing even these small number of quenches is anticipated.

### TRAINING LBL-SSC DIPOLE MODELS (4 Wedge Cross Sections)

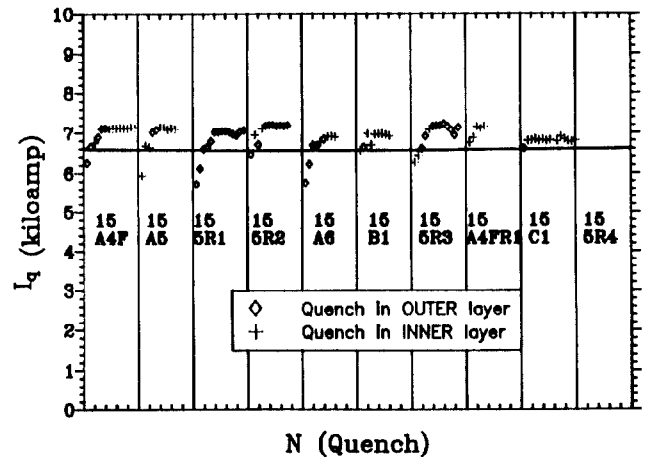

Fig. 8 Recent Tests in He I at 4.3 K

### References

- [1] R.P. Warren, G.R. Lambertson, W.S. Gilbert, R.W. Meuser, S. Caspi, and R.V. Schafer, "A Pressurized Helium II - Cooled Magnet Test Facility", 8th International Cryogenic Engineering Conference, (1980), pp. 373-337.
- [2] D.C. Larbaestier, P.J. Lee, Li Chengren, and W.H. Warnes, "New Developments in Niobium-Titanium Superconductors", ICFA Workshop on Superconducting Magnets and Cryogenics, May 12-17, 1986, Brookhaven National Laboratory.
- [3] M. A. Green, "Calculating the  $J_c$ , B, T surface for Niobium Titanium Using a Reduced-State Model, presented at the 1988 Applied Superconductivity Conference, San Francisco, CA, August 21-25, 1988, IEEE Trans. on Magnetics, MAG-25; also LBL-25926.
- [4] S. Caspi, W.S. Gilbert, and J.B. Rechen, "Ramp Rate Sensitivities of Several Superconducting Dipole Magnets Operated in He I and Superfluid He II", IEEE Trans. on Magnetics, Vol. MAG-19, 3 (1983), pp. 1394-1397.
- [5] W.V. Hassenzahl, S. Caspi, W.S. Gilbert, C. Peters, J. Rechen, and C. Taylor, "A Layer-Wound, 8.7-Tesla Superconducting Dipole Magnet", IEEE Trans. Nucl. Sci., Vol. NS-30, No. 4, Aug. 1983, pp. 3396-3398.
- [6] W.V. Hassenzahl, W.S. Gilbert, C. Taylor, and R. Meuser, "LBL Program on 1-meter-long, 50-mm Diameter Bore, Dipoles with Fields Greater than 8 Tesla", proceedings of the XII International Conference on Particles Accelerators, Fermilab, August 1983.
- [7] W.V. Hassenzahl, W.S. Gilbert, C. Taylor, and R. Meuser, "Progress Toward 10 Tesla Accelerator Dipoles", Journal de Physique, Colloque C1, supplement au n° 1, Tome 45, janvier 1984, p. C1-271.
- [8] Conceptual Design of the Superconducting Super Collider, SSC-SR-2020, March 1986.
- [9] W.S. Gilbert and W.V. Hassenzahl, "1.8K Conditioning (Non-Quench Training) of Model SSC Dipoles", IEEE Trans. on Magnetics, Vol. MAG-19, 1986.
- [10] S. Caspi, "Magnetic Conditioning in Superfluid", presented at the Japan-U.S. Seminar on Basic Mechanisms of Helium Heat Transfer and Related Influence on Stability of Superconducting Magnets, Fukuoka, Japan, August 29 - September 2, 1988.