

## RF PHASE MEASUREMENT AT PHERMEX USING TIME-TO-DIGITAL CONVERTERS\*

S. A. Watson, G. R. Jennings, and D. C. Moir  
Los Alamos National Laboratory  
P.O. Box 1663  
Los Alamos, New Mexico 87545

### Abstract

Recent advances in time-to-digital converters (TDCs) have made 50-MHz rf phase measurement possible without the use of double-balanced mixers. These advances allow zero crossing discriminators to be used in conjunction with fast CAMAC TDCs to make amplitude-independent phase measurements. This method uses a time interval proportional to the phase angle thus eliminating any of the calculations and calibration required with double-balanced mixers.

### Introduction

This paper contains the results of recent research conducted at the Los Alamos National Laboratory's Pulsed High Energy Radiographic Machine Emitting X-Rays (PHERMEX) facility to design an accurate rf (50 MHz) phase detection system to monitor the PHERMEX accelerator's relative cavity phase. The PHERMEX accelerator is a 3-cavity, standing-wave, 50-MHz rf linear accelerator. The rf cavity fields are pulsed for 3 ms with typical peak values of 5-6 MV/m. At peak rf field, a 200-ns, 650-kV, 550-A electron beam is injected from a hot-cathode gun into the first cavity. The phase between cavities is adjusted to maximize beam energy and current transport.

The relative phase between cavities was monitored using double-balanced mixers, both between cavities and for a reference signal in each cavity. The double-balanced mixer's output was then sent to integrating CAMAC analog-to-digital converters (ADCs), which were read by a Data General Micro Nova computer (Ref. 2). The following algorithm was then used to calculate phase:

$$\text{phase} = \text{ATAN} \left( \frac{\text{SQRT}((1-c4*c2*ab / \text{SQRT}(c1*c3*a*b))**2/c4*c2*ab / \text{SQRT}(c1*c3*a*b))+c5}{\text{SQRT}(c1*c3*a*b)} \right)$$

where a = integrated 'alpha' phase mixer signal  
 b = integrated 'beta' phase mixer signal  
 ab = integrated 'alpha-beta' phase mixer signal, and c1, c2, c3, c4, and c5 are the constants that must be obtained to calibrate the system.

The mixer system was complex and inaccurate because it required frequent calibration and because the measured phase was rf-field-amplitude dependent.

A new approach was developed that measured the time interval between zero crossings of two rf-input signals with unknown phase and simply converted that time interval into a phase angle.

### Experiment

The experimental arrangement is shown in Fig. 1. 50-MHz rf signals are detected using B-dot magnetic field loops located in each PHERMEX accelerator cavity. These signals are transmitted via 150 ft of RG-214 coaxial cable into a shielded screen room, where a LeCroy 821 quad discriminator (Ref. 4) is used to detect positive slope, near-zero (-30 mV), crossings. The LeCroy 821 discriminator provides a NIM signal prompt with the zero crossing that acts as a stop pulse for the LeCroy 2228A fast TDC (Ref. 3). Notice that the discriminator is inhibited with an external veto signal applied until the desired measurement time (in this case prompt with the PHERMEX electron gun trigger signal). A common start to the TDC is also provided. The TDC is then read, using standard CAMAC routines, by a MICRO-VAX computer, where a simple FORTRAN program computes and displays the phase, using the following algorithm:

1. Poll for CAMAC L.A.M. flag that occurs when phase is read in by the TDC.
2. Read TDC data.
3. Multiply time data by a constant to obtain data in 50 MHz degrees.
4. If first phase time is less than second phase time, subtract the second from the first and display.
5. If the second phase time is less than the first, add 360 degrees to second phase signal, subtract, and display.

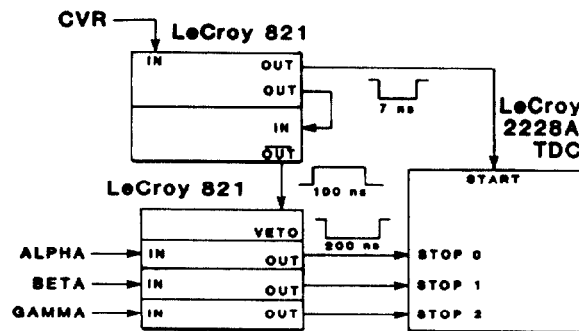

Fig. 1. The PHERMEX rf Phase Measurement System

The system was bench tested with cable delays and trombones over a full period with signals from a frequency synthesizer at strengths of 3-13 dbm (see results in Table I). Similar results were obtained when the system was tested on-line at the PHERMEX accelerator with the signals attenuated to approximately 10 dbm into 50 ohms.

### Results

The accuracy of the detection system was near that of the TDC (50 ps or 1 degree at 50 MHz). Perhaps one degree of additional error was

\*Work performed under the auspices of the U. S. Department of Energy.

attributed to the nonlinearity in the TDC when time intervals of more than one period were measured. This condition occurred when the TDC was enabled between two zero crossings, thereby causing the stop pulse of the first signal to be delayed by one period.

TABLE I  
BENCH TEST RESULTS FOR PHASE ANGLE

Actual Phase Angle (degree)	Measured @ 3 dbm	Measured @ 7 dbm	Measured @ 13 dbm
0 ± .5	-1	-1	-1
36	37	36	36
54	53	54	54
90	89	90	90
126	128	128	128
144	145	145	144
180	180	180	180
216	217	218	218
234	234	232	235
270	270	271	270
306	308	308	308
324	325	326	325
360	359	359	359

Readings with no error = 33%  
 Readings with ± 1 degree error = 41%  
 Readings with ± 2 degree error = 26%  
 Readings with >2 degree error = 0%

#### Conclusion

The detection system described is capable of accurate (± 2 degrees) measurement of phase angle between signals of unknown amplitude at 50 MHz. In terms of simplicity, accuracy, cost, and flexibility it is superior to the double-balanced mixer approach previously used at PHERMEX.

#### Acknowledgements

We would like to thank the Los Alamos Meson Physics Facility (LAMPF) Electronics Pool for the use of their equipment.

#### References

- [1] D. Venable, et. al., "PHERMEX, A Pulsed High-Energy Radiographic Machine Emitting X-Rays", LA 3241 (May 1967).
- [2] C. B. Fite and A. L. Adair, "Pulser/Beam Diagnostic System", LANL Group Report M-4: GR-84-3 (January 1984).
- [3] LeCroy 2228A/2229 Octal Time-To-Digital Converter Operators Manual (February 1985).
- [4] LeCroy 821 Series Quad Discriminator 821, 821Z, 821BCP (August 1982).