

OPTIMIZATION OF PULSE QUALITY FOR A LINEAR INDUCTION ACCELERATOR

S. Eckhouse and M. Markovits

Maxwell Laboratories, Inc.
8888 Balboa Avenue
San Diego, CA 92123

Abstract

Maxwell Laboratories, Inc. has undertaken an effort to develop and optimize Linear Induction Accelerator (LIA) cells and drivers for these cells. Major emphasis was given to improved pulse quality properties regarding the flatness of the accelerating voltage waveshape. As part of this effort, a LIA test stand was designed, constructed, and tested. This paper presents the major design considerations, description of the test stand, results of circuit modeling the LIA cell and its driving pulse power system, and results of testing this LIA system. The measured pulse waveshapes of the tested Linear Induction Accelerator cell are in good agreement with the numerical circuit modeling, and they exhibit a very high degree of flatness, $\pm 0.4\%$ for 65 ns pulsewidth and $\pm 1.2\%$ for 80 ns pulsewidth, for optimal switching conditions. Additional tests underway are described.

Introduction

Induction Linear Accelerators have the capability of accelerating multi kiloamp electron beams to energies of tens of MEVs. Such electron beams find important applications as potential drivers for high power Free Electron Lasers and as sources for deep penetration flash x-ray radiography. Most Linear Induction Accelerator (LIA) applications require a high brightness beam and a small electron energy spread in the beam. In a LIA, the energy spread of the electron beam is mostly controlled by the pulse power source driving the cells of the LIA. The energy variation of the electrons in the beam is directly proportional to the voltage variation in the accelerating pulse sensed by the beam. Other effects, such as space charge or timing errors, may also contribute to the energy flatness, but it is clear that a poor high voltage pulse quality in each accelerating cell will result in a large value of energy spread of the accelerated electron beam. Maxwell Laboratories has undertaken an effort to develop and optimize LIA cells and pulse power drivers for these cells, with improved pulse quality properties. As part of this effort, a LIA test stand was designed, constructed, and tested.

The Test Stand

The test stand includes a pulse power source that uses a Blumlein pulse forming line and an induction accelerating cell. The cell can be loaded with different types of magnetic materials to investigate the interaction between the cell and the pulse power system.

The pulse power system for the LIA test stand is composed of 10Ω ($2 \times 5\Omega$), 100 ns water Blumlein pulse forming line (PFL) that is charged up by a fast 4 stage standard Maxwell Porta-Marx. The Blumlein is switched by a coaxial midplane, low inductance, precision triggered switch that is directly interfaced to the Blumlein PFL. The Blumlein PFL is connected to the cell using two short (3 nsec), parallel rigid 20Ω oil transmission lines that are connected to two HV connector points on the LIA cell. The cell has four identical HV connections. Two of them are used for cable connections, and two for compensating resistors that load the pulse power source in parallel with the cell. The Blumlein, the rigid coaxial lines, and the four HV connectors on the cell are shown in Figure 1. Great care has been taken in the design and construction of the pulse power system and its interface to the induction cell to minimize any pulse distortion effects that may arise as a result of the pulse power system or its cell interface. The main rationale for this "clean" pulse power system design was to try and separate between pulse distortion effects that originate from the pulse power system, from pulse distortion effects that have to do with the induction cell and its magnetic materials. The use of a stiff (10Ω) source to drive

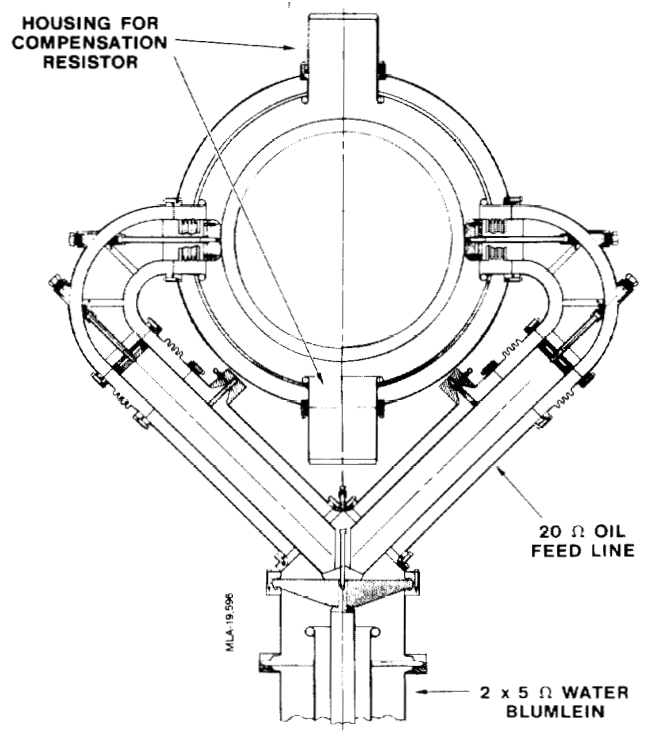

Figure 1. Design of Maxwell Linear Induction Accelerator test stand transmission line.

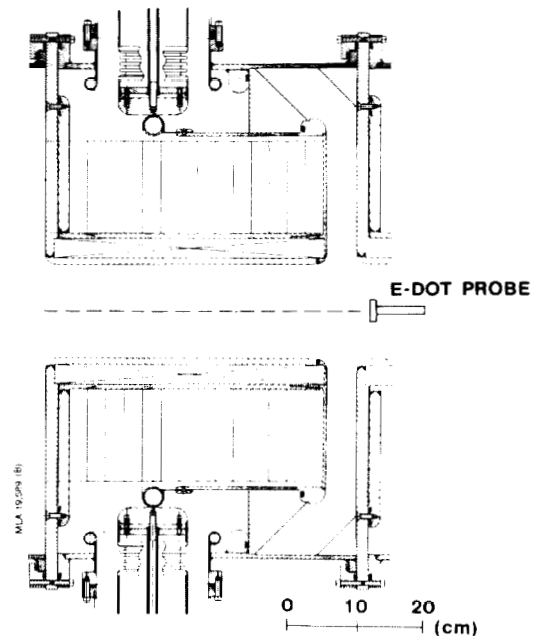

Figure 2. Mechanical layout of test induction cell.

the cell is another significant element in achieving a good HV pulse quality applied to the cell. Such a pulse power source may have limited applications for high repetition rate LIAs where efficiency may be of prime importance, but is an excellent driver for low repetition rate LIAs where the efficiency of the accelerator is not an important issue.

The test induction cell mechanical layout is shown in Figure 2. The space devoted to the magnetic core has an ID of 25 cm, an OD of 50 cm, and a total length of 35 cm. This space can be loaded with a varying number of ferrite cores or Metglass cores. A total axial length of 25 cm in the core volume has a coaxial structure that may behave as a coaxial transmission line loaded with the magnetic material that is tested in the cell. A length of 10 cm does not have this "perfect" coaxial structure. Thus, by comparing the cell electrical behavior with magnetic cores located in these two axial locations, a better understanding of the importance of this type of cell design can be achieved.

The cell uses a radial HV insulator that separates the oil insulated volume of the cell from the evacuated region. The cell and insulator were optimized for minimum HV stresses on the insulator. The cell is also equipped with a water cooled DC focusing solenoid that is part of the cell structure. Great care has been taken in keeping very tight mechanical tolerances in the cell design, in particular in control of the cell axis, the magnetic axis, and the accelerating gap. The cell is constructed in such a way that mechanical control of the cell axis can be achieved without opening the cell or disturbing the accelerator structure when such a cell is integrated into a full LIA structure. The cell can also be conveniently disassembled to facilitate change of magnetic materials for varying test conditions.

Numerical Circuit Modeling

The cell and its driving pulse power system were modeled using Maxwell's MAX-CAP, a simple circuit code, and a Maxwell circuit code equipped with a magnetic material model capability. A simple equivalent electrical circuit model of the cell and its pulse power driver are shown in Figure 3. This simple model models the cell as a lumped constant inductance in parallel with the cell (gap and oil) capacitor and the compensating resistor. The result of the calculated cell voltage signal using this simple model for different switching times of the Blumlein switch are shown in Figure 4. The inductance of the module is based on the use of 14 TDK PE11B ferrites with 25 mm thickness, 50 cm OD, and 25 cm ID. The 35 μ H inductance was calculated assuming a constant magnetic permeability of 500 through the full length of the pulse. As can be seen in Figure 4, the flatness of the pulse depends to a large extent on the switching time of the Blumlein switch. By choosing this time, one can achieve a flat pulse, a positive slope pulse, or a negative slope pulse. A more realistic cell electrical model that takes into account wave effects, was also investigated. For the operating conditions of the cell and pulse power system described in this paper, wave effects do not play a very significant role, judging from the experimental pulse quality that is measured on the cell, as presented below.

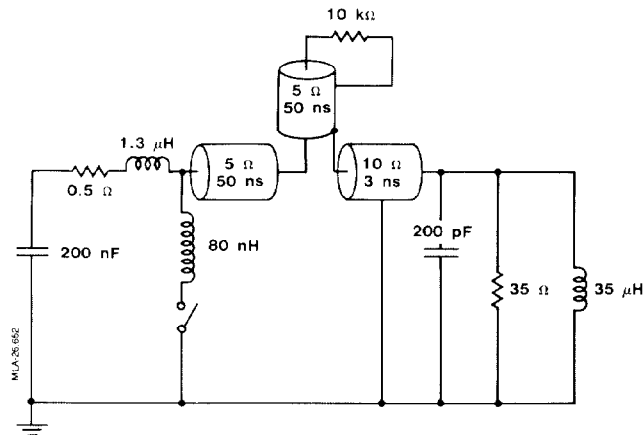

Figure 3. Equivalent circuit of induction cell and its pulse power driver.

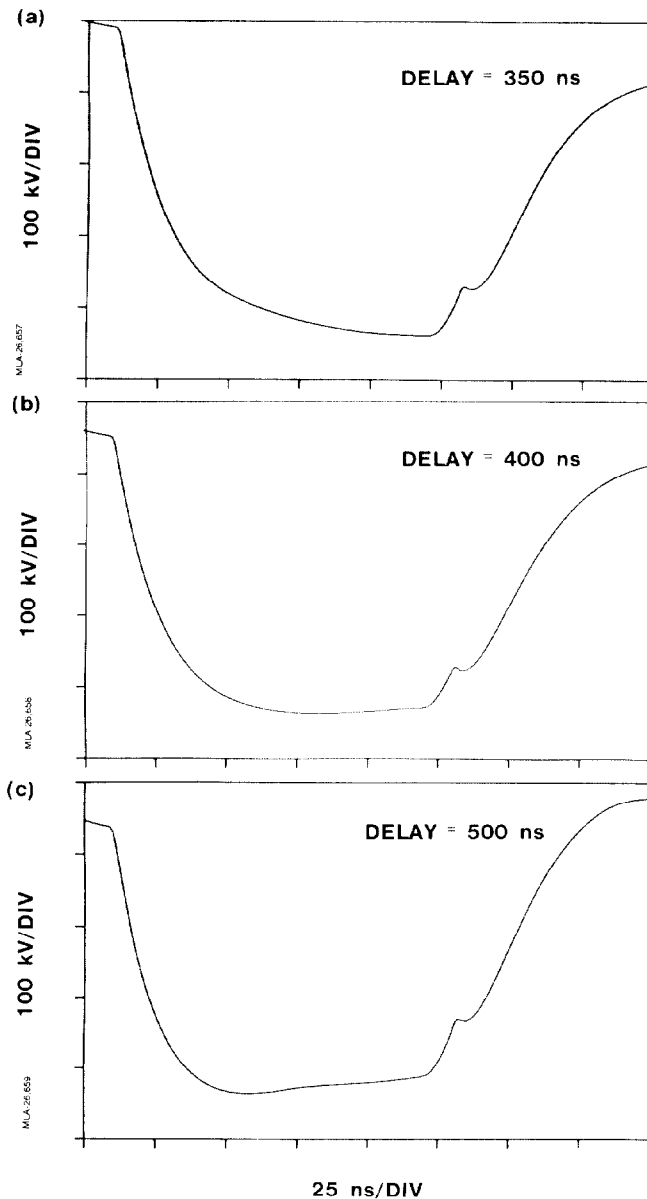

Figure 4. Induction linac module accelerating voltage waveshape simulation for different delay times of the Blumlein switching with respect to the Marx generator erection: (a) 350 ns, (b) 400 ns, and (c) 500 ns.

Measurements Results

For the purpose of diagnosing the pulse propagation into the cell, the cell was equipped with E-dot and B-dot probes that measure local voltages and currents as they propagate into the cell. These probes include a current and voltage measurement probe at the feed to the cell, a current measurement probe that measures the current into the load resistor, and an E-dot probe that measures the induced accelerating electric field at the accelerating gap. This last probe is the most critical one from the point of view of measuring the performance of the induction cell, since it measures the real accelerating voltage that is sensed by electrons when they enter into the accelerating gap. This probe was constructed by wrapping an insulated copper sheet on a rigid coaxial cable that was pushed (see Figure 2) through the drift tube into the gap region. This probe measures the voltage at the center of the accelerating gap.

Figure 5 shows voltage traces as measured by this probe for different triggering times on the Blumlein main switch. As can be seen in Figure 5, the best operating conditions with the "most flat" voltage pulse are achieved for a delay of 410 nsec in the firing time of the main switch with respect to the erection of the Marx generator. This value agrees very well with the value calculated in the numerical circuit modeling. The flatness of the measured pulse is $\pm 0.4\%$ for 65 ns pulsewidth, and $\pm 1.2\%$ for 80 ns pulsewidth. A typical current waveshape measured on one of the ballast resistors is shown in Figure 6, together with the E-dot waveshape as recorded

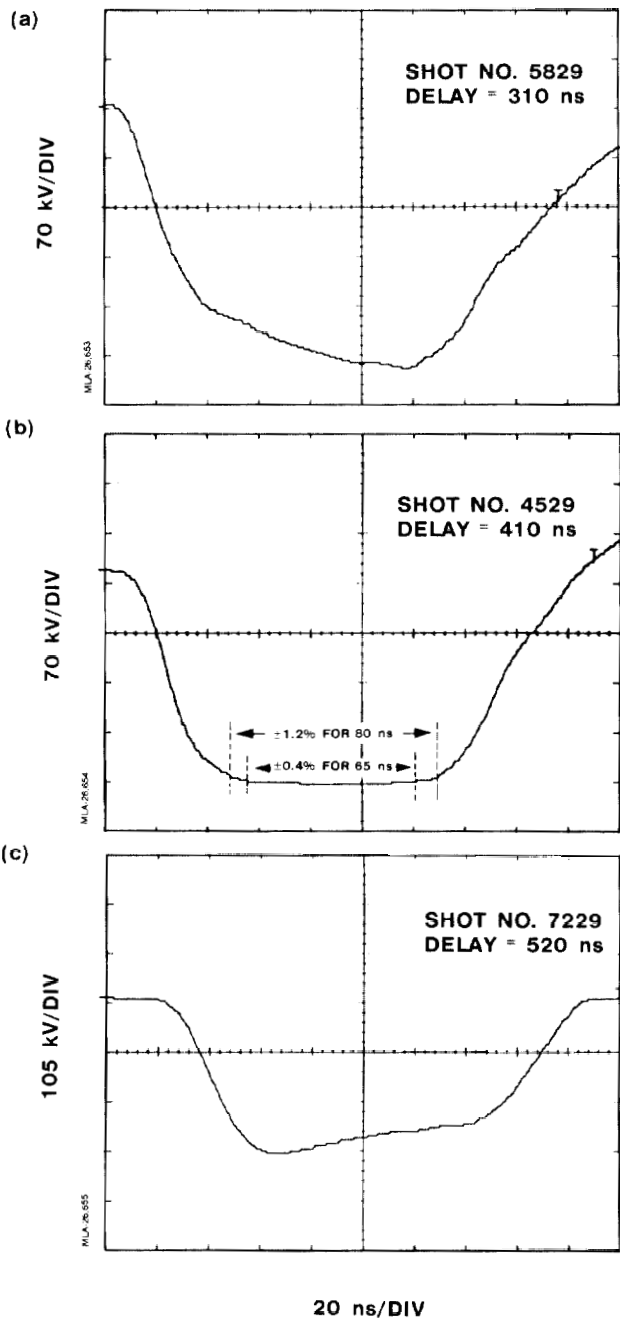

Figure 5. Induction linac module measured accelerating gap voltage waveshapes for different triggering times of the Blumlein switch: (a) 310 ns, (b) 410 ns, and (c) 520 ns.

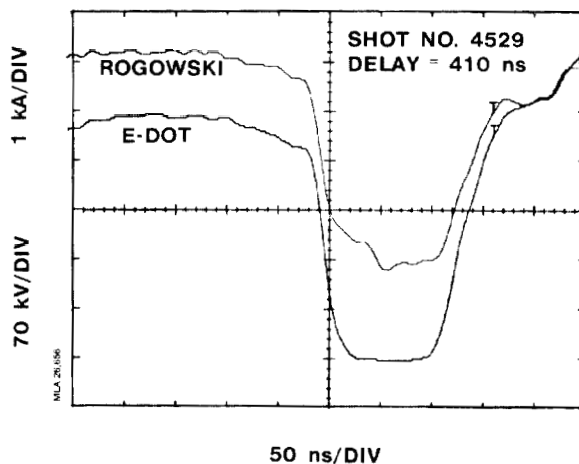

Figure 6. Comparison of compensating resistor current waveshape Rogowski probe measurement to E-dot probe voltage waveshape measurement at the induction cell accelerating gap.

for the same shot as the one shown in Figure 5-b. As can be seen in Figure 6, the current through the (water) ballast resistor has an oscillation superimposed on it. This distortion in the current waveshape is a result of the resonant function of the Rogowski coil used to measure the current, as found during calibration of the Rogowski coil with a square pulse. As can be seen from the measurements in Figure 5, the cell behaves as an ideal inductive load, and no wave effects are observed experimentally.

An additional series of measurements is now underway, where the cell is loaded with a smaller number of ferrites distributed in different locations inside the cell to detect any wave effects that may distort the accelerating voltage pulse shape. We are also planning to carry out a similar series of measurements using high quality Metglass cores that were manufactured and wound by Allied Corporation. These measurements will be done under a joint Allied/Maxwell R&D effort to develop LIAs with Metglass cores that will have superior pulse quality with reduced dimensions. [1]

References

- [1] S. Eckhouse, E. Chu, and M. Montgomery, Scaling Laws and Optimization of Linear Induction Accelerator, presented at the IEEE Conference on Particle Accelerators, Washington, D. C., March 16-19, 1987.