

## ON-LINE MODELLING, A TOOL AT COMMISSIONING OF THE 600 MEV $e^+ e^-$ ACCUMULATOR (EPA) OF LEP

J.P. Delahaye, H. Kugler, A. Lévy-Mandel, F. Perriollat, J.P. Potier  
CERN, 1211 Geneva 23, Switzerland

### Abstract

Today, control computers of accelerators allow the practically unlimited on-line use of powerful lattice programs. Design, commissioning, machine developments and routine operation can to a large extent be based on one program kernel and a set of machine parameters. The major controls aim is to optimize rapidly injection, ejection and beam intensity for energies between 400 and 650 MeV. In this report much emphasis is put on the weighing of benefits against effort at project realisation.

### Introduction

As a part of the LEP injector chain,<sup>1</sup> the main function of EPA (Electron Positron Accumulator) consists in a fast filling rate of 100 Hz with a good efficiency and a strong damping in order to build up 8 dense and stable bunches. The working energy is constant (nominally 600 MeV) within a range (400-650 MeV) to adapt rapidly to possible klystron failures in the injector.

In order to fulfil the numerous design<sup>2</sup> constraints, the lattice was based on two different cells matched together and adapted respectively to the straight and the curved part of the ring. The six quadrupole and two sextupole families allow a perfect adaptation, in a wide range of energies, of betatron tunes and chromaticities to the complicated and energy dependent characteristics of the highly saturated low radius and combined function magnet<sup>4</sup>. Matched optic functions lead to optimum equilibrium beam characteristics and minimum injection and ejection oscillations. These are necessary conditions for efficient accumulation and extraction processes especially for the case of tricky operations like bunch slicing with localised high beta bump.

The accumulator has been commissioned<sup>3</sup> last year with electrons. After a successful start-up from the first day with pre-calculated setting, it rapidly achieved design performances with expected beam characteristics. Available from the beginning, the on-line modelling, based on a good description of the machine, was a very useful, even necessary, tool to adapt the ring energy and setting to the various machine studies and operation conditions.

### Design Ideas for a Commissioning Tool

The driving forces for modelling at EPA were the desire of the designer to use a lattice program on-line. This facility was requested to be available from the very beginning of the running-in time of EPA. The lattice program must be embedded in the control system, and so directly linked to physical elements of the accelerator. This should allow setting up and tuning of EPA with respect to its basic parameters. These include energy, working point in phase space, phase advances, dispersion functions and betatron amplitudes. Chromaticity optimisation was foreseen in view of head-tail effects and dynamic aperture affecting beam intensities.

Damping characteristics of the accumulator lead to a combined function bending magnet, with length to curvature ratio about  $\frac{1}{2}$  and tip fields of 1.6T. This magnet consists mainly of fringe fields with different

degrees of magnetic saturation over the operation energy range.

The magnet properties have been deduced from the multipole components calculated from the analysis of the field measurements<sup>4</sup>. If necessary, the model magnet parameters could be updated on-line, according to measured machine characteristics.

Finally, the decision to implement on-line modelling in the control of EPA was boosted by its success at SLAC<sup>5</sup> and the very encouraging experience made at CERN for ISR and LEAR machines.

### The Control System Infrastructure

In the original design of the PS control<sup>6</sup>, no provision was included to use on-line very large and powerful lattice programs. New mechanisms and tools have now been added. The design goal for these facilities was to be able to install the lattice programs as they became available in the particle accelerator community without any modification, and to provide tools to run these programs by the operators from the main controls console without any knowledge of the operating system of the computer running these programs, and the structure and particularity of the file system and properties of the computer network.

The control computers (ND-100 from Norsk-Data, 16-bit machine), were rejected because the small virtual address space meant cutting the programs into large numbers of overlays, modifications which are not at all acceptable today. The 32-bit ND-560 computer used for control program development was chosen as the target machine for the lattice programs. However, it was foreseen from the beginning of the project that a dedicated computer would be needed to reach adequate response time in the case of matching computation.

The console computers which are the masters of all interactive control activities are the obvious choice for the coordination of modelling activities. They provide powerful display and interaction facilities to the operator<sup>10</sup>. They fully cope with the process of the general coordination and synchronisation of control programs and with the tree structure and virtual machine organisation of the control system<sup>9</sup>. The console computers have also a very efficient access to the process equipment through remote procedure call to Equipment Module in the Front-end Computers. In this way, on-line modelling activities are fully integrated in the control facilities.

A complete set of facilities<sup>11</sup> to manage the activity of the lattice programs in the ND-560 was added to the basic console computer tools. It includes remote job entry and monitoring, files manipulation, files transfer and spooling through the computer network. These facilities were built in such a way that they hide completely the network, and almost completely the special features of the ND-500 operating system. They use a newly developed datagram service, over the private control network. Therefore the lattice programs seem to run locally in the console computer.

All these facilities are available for compiled console programs as well as for the interpreter programming language Nodal<sup>12</sup>. An interpretive language is a powerful development tool for quick prototyping

and for rapid matching to the user request, an essential need for this newly developed control activity.

### MAD, the Chosen Lattice Program

A major aim of the on-line modelling was to use existing lattice programs from the particle accelerator community in order to prevent some ad hoc programs which in any case will result in very high development costs.

The available and well-described lattice programs for on-line modelling as described above were:

- COMFORT (from SLAC), currently used on-line at SLAC<sup>5</sup> and at LEAR;
- MAD (from CERN-LEP), developed under the collaboration between CERN and BNL<sup>6</sup>;
- DIMAT (and DIMAD) from SLAC and Saskatchewan
- AGS (from CERN), but no longer supported by the author.

COMFORT was used for a quick prototyping of the overall service in order to demonstrate the feasibility. The result was very encouraging<sup>7</sup>.

AGS was not considered due to lack of support.

DIMAT was at the time of the studies mainly an accelerator design tool and not yet adapted to the on-line use.

The choice was MAD, as :

i) it had been used extensively already during the design of EPA.

ii) due to its numerous ancillary programs, it has become the most universal lattice program. This makes the transfer of data and results easier for a wide range of studies between on-line and off-line mode. In this way it keeps the provision of new special purpose programs to a minimum.

iii) technically it attributes looked very attractive by the comfortable choice of matching facilities, the computation of beam trajectories and closed orbit perturbations, the off-momentum particle behaviour computation, and the main beam parameters by the synchrotron integrals estimation.

iv) it is an in-house product easing assistance in case of any trouble and giving the chance to profit immediately from the continuous improvements of the program.

The drawbacks of an evolving program are a necessary adaption of the applications to the new version specifications.

### On-Line Commissioning Facility

The MAD lattice program can be used through the "configuration update" program for two purposes: i) a simple computation of the Twiss parameters of the current machine, ii) a matching performed according to parameters modifiable with the interactive tools. In particular one can modify the dispersion at the injection septum, the phase advances at the injection kickers, the tune as well as all the weights attached to those conditions. A results graph for a matching is shown in Fig. 1. Other facilities provided are: scaling of the machine with respect to energy in the range of 400 MeV to 650 MeV, chromaticity correction, rough tune setting. For the two latter options, a computation of the Twiss parameters corresponding to the current machine is first performed automatically. When each operation is finished, the user has the choice to send or not the new values directly to the power supplies, after translation from magnet forces to current respecting the magnetic saturation effects.

The "configuration update" program is written in Nodal. It is organised in an "inference engine" way: according to the values of a state vector variable. The

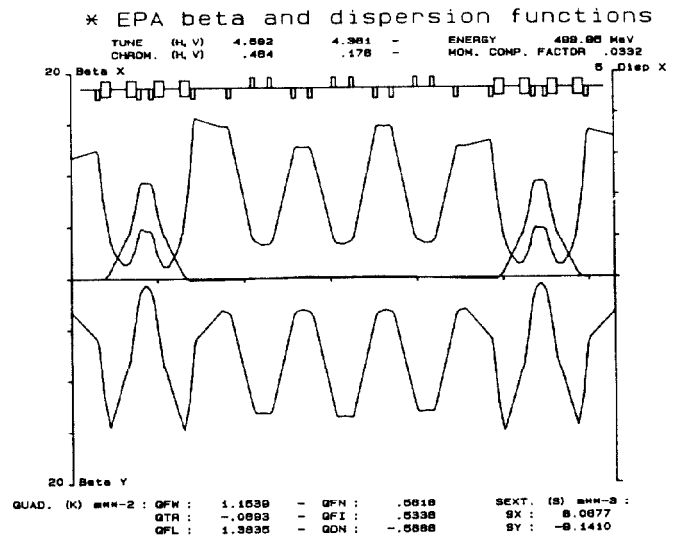

Figure 1

main program will activate a particular set of procedures which modify the state vector value and return it to the main part. The program uses all the interaction facilities of the PS consoles: the user touch panel for option choosing, the alphanumeric colour television for data display and modification, the graphics display for plotting the main results, the tracker ball for the choice of parameters to be modified, the keyboard for performing those modifications and finally various black and white TV screens for the help facility and various further results.

The parts of the program driving MAD make extensive use of the communication facilities between the console computer (ND-100) and the number-crunching machine (ND-500). A reference file containing the nominal configuration of the EPA machine is resident in the ND-500. From this file is derived the MAD input file, according to the actual currents measured in the magnet power supplies and the requested modifications introduced by the user. After the MAD run, the results file is transferred back to the ND-100, for analysis and display. Files and a simplified data flow in both computers are represented in Figure 2.

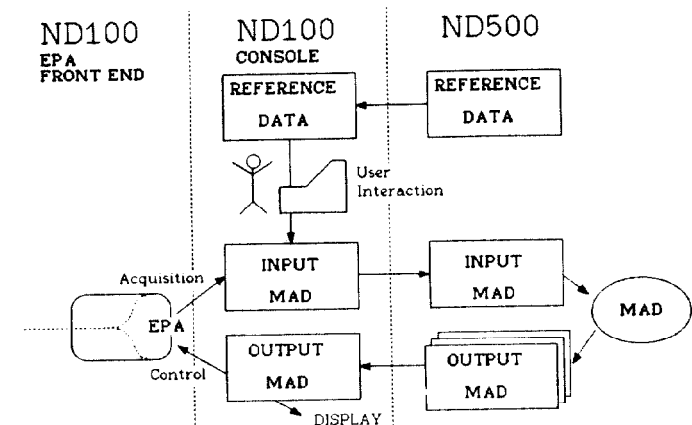

Fig. 2

### Experience Gained During Commissioning

When, for the first time, electrons were injected into EPA and the SEND TO HARDWARE command was executed, which sets up the machine according to the

model calculation, the beam did its first turn with 100% efficiency at once. Adaptation of EPA to LIL energies between 400 and 500 MeV became from the very beginning a one command action with the exception of the readjustments of injection conditions.

Detailed machine studies session on EPA optics confirmed the good agreement between the model and the machine for linear optics<sup>4</sup>. Measurements of the chromaticity provided more accurate values for the sextupole component in the main magnet. The capability to update quickly these parameters in the model of the main bending magnet was proved to be a very useful feature for the studies of machine instabilities and beam intensities. Difficulties of ejections at the nominal working point can be figured out easily with the help of the combination and the complementarity of on-line modelling and off-line studies. Setting-up, verification of machine status and tuning was done by "configuration update" program daily.

At implementation of on-line modelling on control systems, two performances need special attention and demand sufficient resources from the start:

- i) response time,
- ii) graphic representation facilities.

The heavily loaded computer ND-560 (due to intensive program development activity for the LEP injector control) and the very general minimization routines used in MAD (not at all optimized for CPU time consumption) may lead to unacceptable long response times, in our case 10 to 15 minutes typically. For a matching calculation graphic facilities should - apart from displaying machine situations in form of lattice functions - allow the observation of their evolution when tuning takes place. The bad response time for matching and the lack of graphic facilities reduce the degree of convenience of the tool.

#### Time Scale, Effort, Benefits

This pilot project started in Autumn 1984 and lasted 27 months. Of this period, 9 months were spent on preparatory work and for a quick prototype for feasibility study<sup>7</sup>, one year on realisation of the software and 6 months on its consolidation. About 3 man-years of effort went into its complete realisation, all participants working on it part time only. It must be underlined that this includes the set-up of all the software infrastructure for this new control activity.

Benefits are threefold:

- i) At EPA on-line modelling facilities were a valuable assistance at running-in and also have become a tool in routine operation, with its installation, the basic block for optimization programs (e.g. injection, ejection) has been provided, and a standard for an incorporation of the transfer lines into the scheme has been set.
- ii) For the PS complex the infrastructure for future installations of on-line modelling tools has been established, validated and substantiated to be efficient.
- iii) In-house experience has been gained in the introduction into a control system of a universal lattice program, normally reserved for the design of accelerators. This program is directly usable by the casual operators as well as by the machine physicists.

#### Future Development

Two major areas of development are currently being followed: (i) increase the performance of the service, ii) more high level applications.

Increasing the performance will be done by transferring the number crunching activity to the more powerful ND-570 computer recently bought. This computer provides array processing floating instruction which could be used to reduce the cpu time consumed by minimization routines. It is hoped that the manufacture network Cosmos will give more powerful and efficient tools for communication between console computer and the number crunching machine.

New applications are being built for EPA injection and accumulation adjustment, for closed orbit deformation and correction simulation, for LIL to EPA and EPA to PS transfer the setting up and for LIL V and LIL W trajectory correction. The last one will use an extended version of DIMAD program including radiofrequency cavity surrounded with solenoid magnet or quadrupole magnet.

Other applications are built or foreseen for the other machines of the PS accelerator complex.

#### References

- [1] The LEP injector study group, "The LEP injector chain", CERN-LEP/TH/83-29.
- [2] J.P. Delahaye and A. Krusche, "The Lattice Design of the LEP Electron Positron Accumulator", Proceedings of the Particle Accelerator Conference, Vancouver, 1985.
- [3] J.H.B. Madsen et al., "First Experience with the LEP-Injector (LPI) by the LPI Commissioning Team", these Proceedings.
- [4] M. Bell et al., "The Model of the Bending Magnets Used in the 600 MeV e<sup>+</sup>/e<sup>-</sup> Accumulator of LEP", these Proceedings.
- [5] M.J. Lee et al., "Models and Simulations" SLAC-PUB-3214, September 1983.
- [6] F. Ch. Iselin, "The MAD Program", CERN/LEP-TH/85-15, 15 May 1985.
- [7] F. Perriollat, "Modelling, Analysis and Results of the Feasibility Study", CERN, PS/CO/Note 85-3, 1985.
- [8] G. Baribaud et al., "The Improvement Project for the CPS Controls", Proceedings of the Particle Accelerator Conference, San Francisco, 1979.
- [9] P.P. Heymans and B. Kuiper, "Concurrent Control of Interacting Accelerators with Particle Beams of Varying Format and Kind", EPA Europhysics Conference, Computer in Accelerator Design and Operation, Berlin, 1983.
- [10] R. Debordes et al., "The Main Operator Consoles for the PS Accelerator", Proceedings of the Conference on Particle Accelerator, Vancouver, 1985.
- [11] F. Perriollat, "The Environment of the PS Controls System for On-Line Modelling Facilities", CERN, PS/CO/Note 86-012, 1986.
- [12] M.C. Crowley-Milling, G.C. Shering, "The Nodal System for the SPS", CERN 78-07, September 1978.