

MAGNET POWER SUPPLY FOR ISABELLE*
R.J. Nawrocky, R.F. Frankel and M.G. Thomas†

Summary

The power supply system which will energize the superconducting magnets in the ISABELLE machine consists of some 520 computer-programmable power supplies with outputs ranging from 50 A to 4500 A. Most of the power supplies will be used for the correction of field harmonics, orbit correction and adjustment of the machine working line. During acceleration, currents in various magnet correction coils will be controlled in real time to track the main field; all power supplies must be highly stable during the stacking and storage of the beam (in some cases current regulation must be in the order of 0.001 %). PS reference programs will be stored in microprocessor based function generators embedded in each power supply. Due to the large amount of stored energy in the system, the magnets must be protected during quenches. Details of the power supply and of the magnet quench protection system are described.

Introduction

In the ISABELLE machine presently under construction at BNL, each accelerator ring contains 540 superconducting magnets; 366 dipoles, 138 regular quadrupoles and 36 special quadrupoles in the insertion regions. The main windings of all magnets are connected in series and energized with a single, current programmable, bidirectional converter type power supply. The current is ramped from about 300 A (injection/stacking) to 4170 A (peak energy) once every 12 hour period. The stored energy in the circuit at full field is in the order 380 MJ. This energy is returned to the line during normal de-excitation of the magnets,

Due to the large amount of stored energy in the system, a reliable protection scheme is required to protect the magnets from damage during quenches and to prevent magnet-to-magnet quench propagation. This scheme consists basically of cryogenic by-pass diodes connected across each magnet coil and an energy extraction system. In each machine sextant, the diodes provide a by-pass for the current around quenched magnets and the extraction system diverts the energy stored in the remaining superconducting magnets into external energy dump resistors. Since the kinetic energy of the circulating proton beam may be as high as 38 MJ, it is imperative to eject the beam out of the machine in the event of a magnet quench. A detection system will be implemented to detect quenches in all magnet coils. This system will generate appropriate triggers to beam extraction equipment and to the magnet energy dump system.

In addition to the main coils, the magnets contain a number of other coils for the correction of systematic field harmonics, closed orbit correction and for adjustment of the machine working line. Each set of systematic correction coils and of the quadrupole trim coils is powered in series around the ring. Steering dipoles for closed orbit correction and trim coils on the insertion quadrupoles are powered individually. Electrical coupling between various correction coils and the main coils is negligible except in the case of quadrupole trim. A physical layout of the magnet system and power supply is illustrated in Fig. 1.

*Work performed under the auspices of the U.S. Department of Energy.

†Brookhaven National Laboratory, Upton, NY 11973

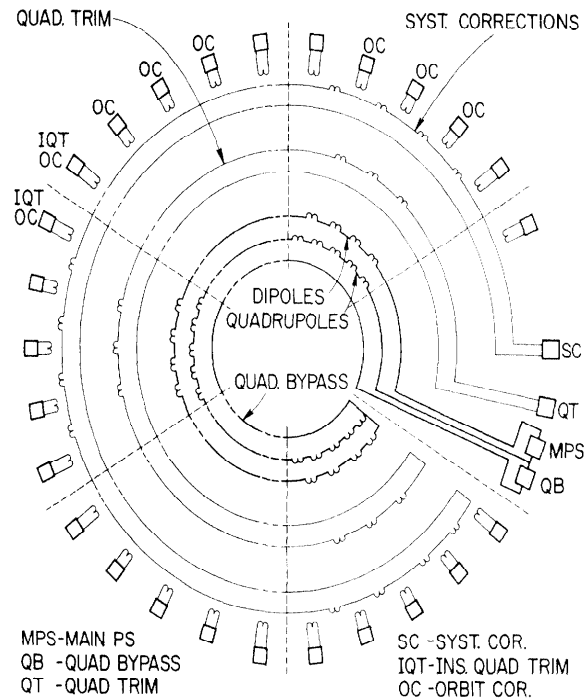

Fig. 1 Magnet Power Supply System (each accelerator ring)

Main Magnet Circuit

The main magnet circuit in each ring is energized with a power supply consisting of two SCR controlled units connected in parallel; a high voltage bidirectional converter for energy transfer during acceleration and magnet de-excitation, and a low-voltage, low-ripple unit for holding during the stacking and storage of the beam. The power supply operates in the current regulating mode; a field regulating loop will be used during the beam storage phase. Both passive and active filters are used to reduce the current ripple to the required level. Current sensing is accomplished by means of a zero-flux type current transducer and the power supply reference program is derived from a 16-bit, state-of-art D/A converter.

The main magnet circuit consists of three buses, as illustrated. The dipoles and the insertion quadrupoles are in the forward bus whereas the regular quads are in the return bus. A by-pass power supply diverts some current around the quadrupoles to compensate for the difference in the saturation of the iron in the dipoles and the quadrupoles. Parameters of the main and by-pass power supplies and of the magnet load are listed in Table I. A typical magnet excitation cycle is shown in Fig. 2.

Magnet Correction System

In all dipoles and quadrupoles there are additional coils which will be used to correct the field shape and will provide control of the machine working line. Systematic errors in the magnetic field will arise due to iron saturation effects, construction of the coil ends, diamagnetic effects in the superconductor, and rate-dependent induced currents. Imperfections in magnet construction and in physical placement of the magnets in the ring will result in field

errors that vary randomly from magnet to magnet. The primary effect of the random field errors will be to displace the central orbit. A system of steering dipole coils, each powered by an independent power supply, will be used to reduce the orbit displacement to about 1 mm around the ring and to within 0.1 mm in the vertical direction at the intersection points of the two accelerator rings. Skew quadrupole coils are provided to suppress certain imperfection resonances which may be caused by the random field errors. The shape of the machine working line will be controlled with a set of independently powered coils in the regular quadrupoles¹. All correction power supplies will be programmed in real time to track the main dipole field.

Table I

Main Power Supply

No. of Energy Transfer Stations	1	
No. of Holding Stations	1	
Peak Current (transfer)	4500	A
Peak Current (holding)	4500	A
Peak Voltage (transfer)	1000	V
Peak Voltage (holding)	100	V
Current Tolerance- long term	45	mA
- ripple	0.5	mA

Magnet Load

Dipole Inductance (main coil)	0.1	H
Quadrupole Inductance (main coil)	0.01	H
Quad. Main-Trim Mutual Inductance	0.006	H
Total Circuit Inductance	38.3	H
Circuit Resistance	0.02	Ohm
System Time Constant	1915	sec
Peak Bus-to-Bus Voltage	1000	V
Peak Bus-to-Ground Voltage	1000	V

Quadrupole By-pass Power Supply

Peak Voltage	150	V
Peak Current	±300	A
Current Tolerance- long term	4.5	mA
- ripple	0.5	mA

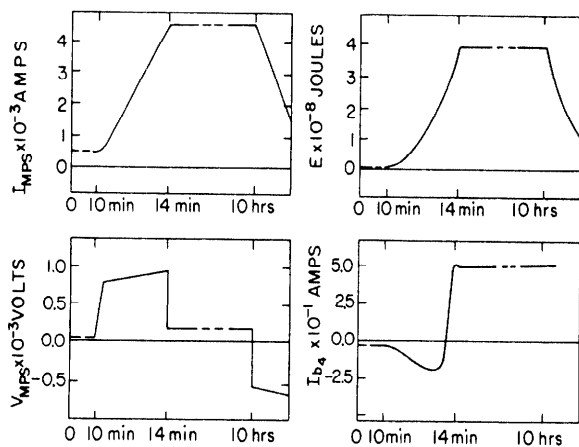

Fig. 2 Typical Magnet Excitation Cycle

The magnet correction system for one ring is summarized in Table II. In the table are listed the various types of corrections together with the corresponding current and current tolerance requirements. Basically, the power supplies will be current regulated, transistorized power amplifiers with push-pull output stages; in some cases field regulation may be required (for ex. the b_2 correction). The compliance voltages of the various units fall into three ranges: ±10v, ±75v, and ±125v.

Table II

Correction ⁺	Location [*]	Current A	Cur. Tol. ppm FS	No. of Ckts/ ring
b_2	B	±300	10	2
b_3	B	± 50	25	2
b_4	B	± 50	50	2
b_1	QF,QD	±300	50	2
b_5	QF,QD	± 50	125	2
a_0	QD,IQ6	± 50	200	66
b_0	QF,IQ7	± 50	200	60
a_0	IQ1,IQ4	±100	200	24
b_0	IQ2,IQ5	±100	200	24
b_1	IQ1	+300	175	12
b_1	IQ2	+300	175	12
b_1	IQ4	+300	500	12
b_1	IQ5	+300	350	12
b_1	IQ6	+300	350	12
b_1	IQ7	+300	350	12
a_1	IQ1&IQ2	± 50		2

⁺ b_n and a_n are defined by: $B_y = B_0(1 + \sum_n b_n x^n)$,
 $B_x = B_0(1 + \sum_n a_n y^n)$.

*Magnets: B-dipole, QF-focusing quad., QD-defocusing quad., IQ-insertion quad.

PS Controllers

Each magnet power supply will have an embedded microcomputer which will perform a variety of control, monitoring and communication tasks. Although small in size and low in cost, the controller adds the local intelligence necessary for communication with a control computer, increases functionality available, and reduces the size of PS control circuitry.

The hardware consists of an 8085 microcomputer, a 512 byte random access memory (RAM), a programmable read-only memory (EPROM), parallel input/output ports and counters. The controller components are optically isolated from the power supplies to avoid ground loops. The system operates in a multitasking mode with three levels of priority in foreground. The foreground programs in order of priority are: reference program generator (FGEN), PS fault checking (FAULT), and computer interface (via IEEE-488 interface bus). Background is used to control power supply status, i.e. turn-on, turn-off, etc.

The function generator may be programmed to fit various PS reference functions with a sequence of linear ramps. In FGEN, a break-point rate system is used; this method of function generation is efficient in memory size, produces an output that can be easily filtered, and interfaces to a microcomputer with minimal hardware. A sixty end-point table requires only 240 bytes of RAM.

The fault checking system is designed to protect the magnet as well as the power supply itself. Some faults are fatal and cause power supply shutdown, others

allow for a controlled ramp-down, and still others merely report the problem. A "watch dog" circuit is included for increased system protection.

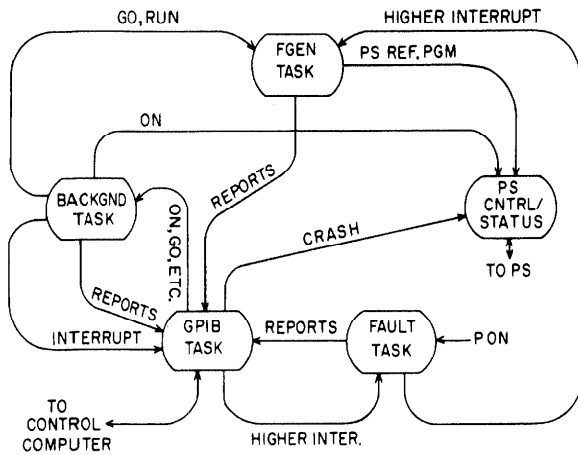

Fig. 3 PS Controller State Diagram

Magnet Quench Protection

A system is being developed to protect the ISA magnets from destructive energy dissipation during quenches. The system must detect faults at an early stage, rapidly extract the high energy proton beam out of the machine and divert the stored energy in the magnet string around the quenched units.

To detect quenches in each coil, an array of digital pulse trains with frequencies proportional to the coil voltages will be generated and transmitted to a central location for processing. Receivers will be updated every millisecond to detect quenches at an early stage. Low level signals injected at the system input, but well below the quench threshold, will continuously transmit low frequency pulse trains to insure system integrity. A missing pulse detector will set an alarm in case of faulty circuitry.

After a quench is detected, the fast beam extraction system will be activated and the energy diversion sequence initiated. As the resistive voltage of the quenched magnet rises to approximately 25 volts, a cryogenic by-pass diode will conduct and quickly reduce the magnet voltage drop to about 2 volts³. A single magnet is capable of dissipating only its own energy; the diode will act as a current by-pass preventing the system stored energy from being deposited into the faulty unit.

In the ISA, each sextant of the ring will be isolated and by-passed by means of several SCR switching assemblies (see Fig. 4). The by-pass SCRs will be gated on, followed by the commutation of the isolating SCRs. This will enable the sextant to decay into an external dump resistor with a time constant of about 14 sec, while the rest of the ring will be ramped down at a slower rate. The rapid decay is necessary

to prevent magnet to magnet quench propagation due to high pressure warm gas front generated by a quenched magnet. Exhaust ports will be provided in each magnet to expel the warm gas.

System Prototypes

First prototypes of computer-controlled main and correction power supplies for ISABELLE have been developed and tested in the ISA Half-Cell prototype in the spring of 1976⁴. Development of second generation power supplies is underway; these units should be ready for system tests in the fall of this year in the ISA First-Cell. The new power supplies will be more compact, will have a higher power conversion efficiency, and will utilize the newly developed 8055 microcomputer based PS controllers.

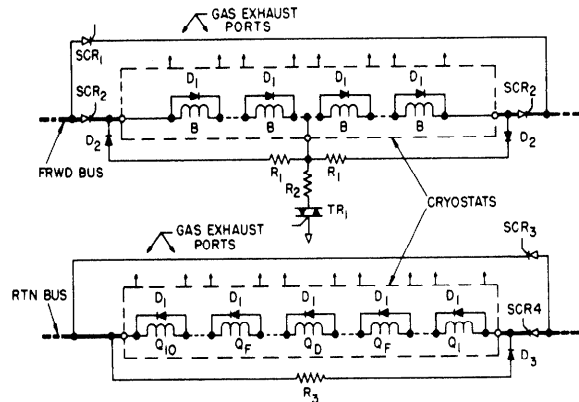

Fig. 4 Magnet Energy Extraction Circuit (sextant of each ring)

For the magnet quench protection system, tests on the by-pass diodes have shown that thermal cycling and switching of high currents have little effect on the device characteristics. Interpolation of radiation data indicates that radiation will cause a small increase in the diode forward voltage drop; this effect is, however, reversible and the diode drop can be returned to normal value by thermal cycling. Some tests on the diodes and switching SCRs in a magnet string have been performed in the Half-Cell. Further testing will be continued in the First-Cell.

References

1. BNL Report 50718, pp. 118-122.
2. Nawrocky, R.J., ISABELLE Informal Report (in preparation).
3. Robins, K.E., Sampson, W.B. and Thomas, M.G., IEEE Transactions on Nuclear Science, Vol. NS-24, No. 3, June 1977, pp. 1318-19.
4. Nawrocky, R.J., IEEE Transactions on Nuclear Science, Vol. NS-24, No. 3, June 1977, pp. 1358-60.