

AN INEXPENSIVE POSITRON CONVERTER OF HIGH RELIABILITY AND HIGH YIELD

G. Stange

Summary

A new positron converter of the simplest construction is described, consisting of a multiple fixed tungsten target and a very small helical positron lens, both inside a small vacuum chamber. By utilizing the good vacuum insulating properties the lens may be pulsed with 6000 A at an operating voltage of 10 kV without insulating material, except for the vacuum feed throughs, for which the extremely radiation-resistant aluminiumoxide ceramic is used. The lens construction out of a copper pipe allows direct water cooling and gives sufficient mechanical strength without further reinforcement. The system has been in operation for 3 years and gives a positron conversion ratio I^+/I^- of 0.8 % as a routine value for an e^- energy of 300 MeV, where the positron energy spread is within ± 1.5 MeV. Compared to a dc-lens saving factors of about 500 in weight, 50 in power consumption and 100 in cost have been achieved.

Introduction

The surrounding of positron converter targets in positron linacs is subject to heavy γ -radiation with the consequence of severe reliability problems of the magnetic focusing devices. Especially the positron lens, which is located in the immediate neighbourhood of the target, suffers from this load if organic material is used for its insulation. In the DESY 400 MeV positron linac dose rates of up to 10^{10} rad/h have been measured during operation in about 10 cm distance from the target. This value has to be related to the maximum dose of about 10^{12} rad, the best organic insulators are able to withstand¹. Experience at DESY with a dc positron focusing lens, using an epoxy resin as insulating material, showed a lifetime of a few months only. Obviously it failed by aggressive chemical agents generated by the combined presence of organics, oxygen, nitrogen and air moisture under the influence of radiation. These agents caused damage of the directly water-cooled copper conductors of the lens.

To overcome these difficulties it is necessary to avoid organic material in the neighbourhood of the target as far as possible. Therefore we studied the possibilities of a magnetic positron lens, which is located inside the vacuum system, utilizing the high vacuum breakdown voltage. Additionally development work on a fixed target was started. The result was an extremely simple unit, which we call positron converter. It consists of a multiple fixed tungsten target and a pulsed very small helical coil as a lens, both inside a separately pumped vacuum chamber. This system will be described in the following sections. The high voltage pulse generator will be included.

Optical Considerations

The evaluation of the lens data is the result of an optimizing procedure taking into account the characteristics of positron production and the type of focusing system on the first positron accelerator section, to which the positron beam has to be optically matched by the lens^{2,3}. The aim is an optimization of the transverse and energy acceptance of the lens. We used an extensive computer program for this purpose³. The results concerning the lens data and the geometrical arrangement of the target, lens and accelerator input are listed in table 1.

Deutsches Elektronen-Synchrotron DESY
 Notkestrasse 85, 2000 Hamburg 52, W. Germany

inner diameter	25 mm
outer diameter	45 mm
length	45 mm
distance target-lens	5 mm
distance target-accelerator input	220 mm
ampereturns	88000 A
maximum axial field	2 T
center energy of accepted energy band of positrons	10 MeV

Table 1: Results of Numerical Calculation Lens Data from Optics

As an example for the numerical results fig. 1 shows a calculated plot of the axial field of the lens at a current of 5000 A,

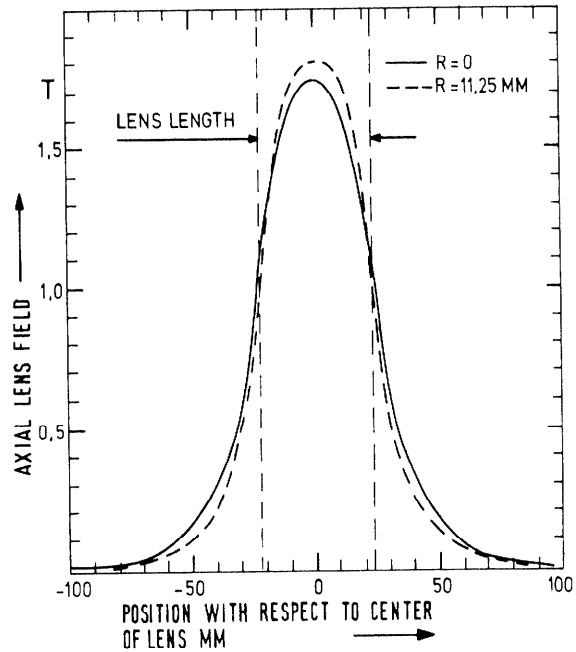

Fig. 1: Axial Magnetic Field of e^+ -Lens (Calculated)

and fig. 2 shows the calculated space angle Ω (in sterad) of the lens as a function of energy for a lens current of 5.5 kA, a spot size of 3 mm, and a 0.4 T solenoid field on the first positron section. The computer calculations show, that the distance target-lens has to be as small as possible. In regard to technical arguments a distance of 5 mm has been assumed for the acceptance calculations of fig. 2.

The geometrical arrangement from the target to the input of the following accelerator section is shown in fig. 3. The secondary emission monitor (SEM) in front of the target allows steering of the electron beam on the target by means of a circular hole in the SEM-foil. In correct position the electron beam is passing the hole and leads to a zero or slightly negative signal of the SEM, whereas a positive signal indicates missteering.

Technical Realization of the Lens

The technical realization of the lens has to meet several boundary conditions. The high average current density of 200 A/mm^2 over the coil cross section, which follows from the data of table 1, can only be achieved in pulsed operation. The pulse length should be as small as possible, however, with a minimum flat top ($\pm 2\%$) of 1 μsec , corresponding to the beam pulse length.

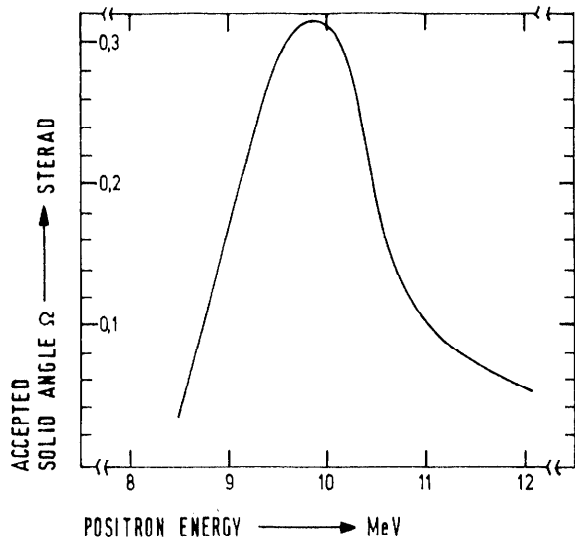

Fig. 2: Calculated Solid Angle Acceptance of e^+ -Lens at 5.5 kA incl. Optical Properties of the Whole e^+ -Focusing System

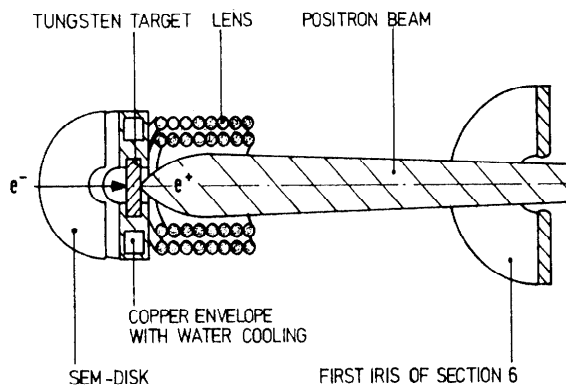

Fig. 3: Schematic Arrangement of Initial e^+ -Production and Focusing

So the average power consumption can be made minimum. Furthermore the coil does not need any reinforcement if the frequencies contained in the pulse are high compared to the mechanical resonance frequencies of the winding system. In the interest of reliability of the high voltage pulse generator and small cost the operating voltage should be 10 kV max. With the additional condition of small pulse length this requires a low coil inductance, i.e. low number of windings. The number of windings is on the other hand determined by the value of ampere-turns (table 1) and the maximum pulse current to be switched with the pulse generator. The sum of these arguments led to the following operating and construction parameters of the lens (table 2).

length	46 mm
inner diameter	25 mm
outer diameter	45 mm
number of windings	16
number of layers	2
windings per layer	8
conductor:	hollow copper pipe, 4 mm outer diameter, 1 mm wall thickness
spacing between neighbouring windings	2 mm
spacing between layers	2 mm

max. axial and radial force on single winding	1200 N
cooling of conductor	directly by water
connections	to the 2 center windings of outer layer
inductance	4 μ H
max. current	6000 A
max. voltage	10000 V
max. electric field strength between windings	80 kV/cm
max. axial magnetic field	2 T
pulse length, form support	10 μ s half sine wave lens self supporting, connectors reinforced by ceramic spacer, whole lens supported by feed through, which has aluminiumoxide for insulation

Table 2: Constructional and Operating Parameters of Positron Lens

Table 2 makes evident the simple construction of the positron lens with the main advantage of extreme radiation resistance, because the only insulating medium besides vacuum is aluminiumoxide ceramic for the feed throughs of the lens connectors.

Construction of the Positron Converter Unit

Fig. 4 shows a cross section of the positron converter unit with SEM, multiple fixed target, positron lens, housing and attached flanges. In the electron mode of the linac only target and SEM are retracted from the beam center line, whereas the lens stays in position. Input and exit flanges are specially constructed for quick mounting by means of clamps. The housing is manufactured from stainless steel. The exit wall as well as the exit flange are armed with water-cooled copper insertions acting as collimators. They absorb and scatter a large amount of radiation before it hits the copper sealing discs at the accelerator input, where it may cause thermal problems. The housing is directly pumped with an ion getter pump. The targets are 14 mm diameter discs of pure tungsten with a thickness of 7 mm. They are enclosed by a water-cooled copper frame.

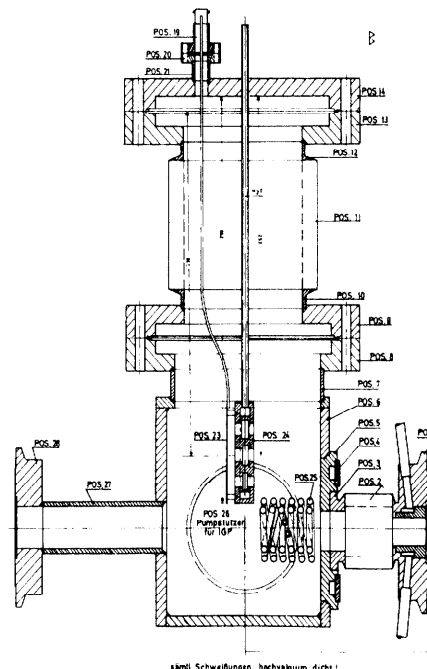

Fig. 4: Cross-sectional View of Positron Converter

In case of failure of one target by fatigue the next target may be simply used similar to the revolver principle.

Pulse Generator

The pulse generator is located outside the linac tunnel and is connected to the lens by 8 parallel coaxial cables, 60 Ω each. Since both lens connections are potentialfree, the outer conductors serve as return path for the pulse energy. Fig. 5 shows the pulse generator circuit, the pulse energy being stored in the capacitor C_1 . With a total capacity of 2.5 μF it is composed of 5 units with 0.5 μF each, which are directly water-cooled. This turned out to be necessary, because of the voltage swing of nearly 100 % from positive to negative polarity during the pulse, which is accompanied by high dielectric losses.

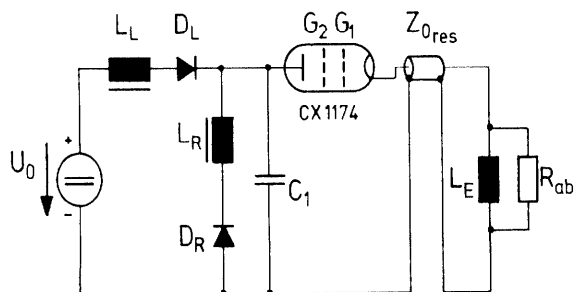

Fig. 5: Pulse Generator Schematic Circuit Diagram

The pulse generator is of the regenerative type. After the main pulse has ceased, the capacitive energy in C_1 swings back through L_R . So only Ohmic losses have to be supplied by the external source U_0 . The switch is a ceramic thyatron (CX 1174, EEV), capable of 40 kV and 6000 A max. The max. repetition rate is 50 pps. Table 3 lists the main data of pulse generator and load.

dc-source	3 phase full wave rectifier
dc-volts, U	10 kV
charging choke L_L	10 H
recharging choke L_R	0.1 H
storage capacitor C_1	2.5 μF
load inductance L_E	4 μH
additional parasitic inductance	2 μH
resultant wave impedance of cables Z_{res}	7.5 Ω
matching resistor R_{ab}	7.5 Ω
max. current	6000 A
pulse length	10 μsec
max. repetition rate	50 Hz
average Ohmic losses	2 kW

Table 3: Main Data of Pulse Generator Load

Measurement of Optimum Target Thickness

With the described type of converter it was possible to measure the influence of target thickness on positron yield because different targets may be brought in position without changing the optics at all. Fig. 6 shows the results. For electron energies between 200 and 300 MeV a thickness of 7 mm tungsten turned out to be optimum. This corresponds to two radiation lengths.

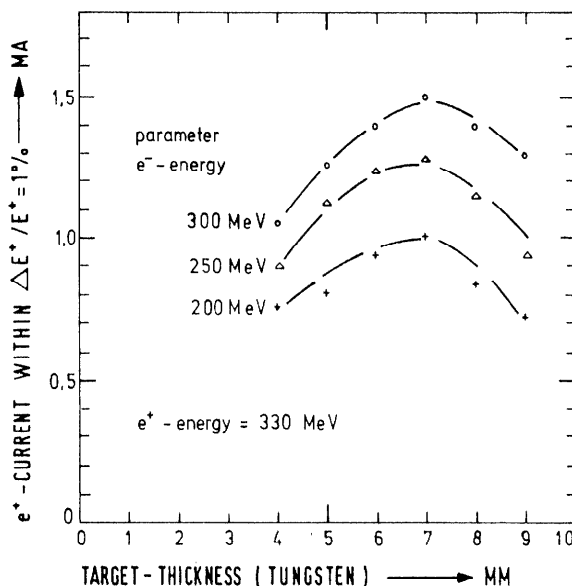

Fig. 6: Analyzed e^+ -Current within $\pm 1/2 \% \Delta E^+/E^+$ as a Function of Target Thickness

Operating Experience

The system is working since more than 3 years. Apart from minor problems with the retraction mechanism, which were caused by radiation-induced dissociation of grease and subsequent corrosion in the supports, the system worked without any problems and no maintenance at all. The observed electron/positron conversion ratio of 1 % max. and 0.8 % as a routine value for e^- and e^+ energies of 300 MeV each and within a positron energy spread of $\pm 0.5 \%$ agree very well with the calculated yields³.

Comparison with a dc-lens, which had been in use at DESY² showed an improvement by almost a factor of 2 in useful positron intensity. Besides that there are technical and economical advantages of the pulsed version. The dc-lens had a total weight of 150 kp and a power consumption of 100 kW compared to 0.3 kp and 2 kW respectively for the described pulsed lens. The saving factor in cost for the pulsed system with respect to a dc-system - including the power supply in each case - is at least 100.

References

- G. Pluym and M.H. van de Voorde
"Radiation Damage of Epoxy Resins Used in Magnet Coil Insulation"
International Conference on Magnet Technology, Oxford, 1967
- A. Febel, G. Stange
"LINAC II"
Internal Report DESY S 1-72/3, August 1972
- G. Stange
"A Pulsed Magnetic Lens for Positron Focusing, Numerical Calculation and First Measurements with a Prototype"
Internal Report DESY S 1-73/4, August 1973