

INTRODUCTION

The multiturn injection of H^- ions into the Fermilab 8 GeV Booster Synchrotron requires the shifting of the closed orbit towards the injection stripping foils so as to allow circulating protons to align with injected negative ions at the stripping foils. During this interval the amplitude of the orbit shift or "bump" is required to remain essentially constant as each successive turn is injected. The length of the flat top must allow for as many as 50 turns of H^- injection, with an injection energy revolution time of 2.78 μ sec. After injection, the circulating beam must clear the stripping foil by the tenth subsequent revolution. This would restrict the beam growth due to multiple scattering to a tolerable level and still allow a reasonable amount of time to remove the stored energy from the magnets. A reverse di/dt of 670 A/ μ sec will yield the required radial beam shift of 2 cm within 30 μ sec.

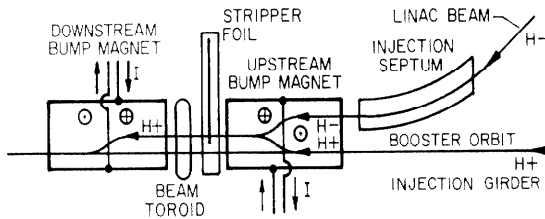

Figure 1. Basic Layout of Injection Girder.

As shown in Figure 1, this local orbit bump is produced by a symmetrical pair of double bend magnets. Further discussion of the Fermilab injection girder and bump magnets occurs elsewhere in these proceedings.¹

The power supply used to furnish excitation current to the orbit bump magnets is of the Pulse Forming Network type utilizing a constant value of capacitance and variable inductors. Energy stored in the PFN is delivered to the magnet load via a series-parallel array of thyristor switches. The power supply is located in the equipment gallery of the booster synchrotron and the injection girder is located about 5 meters below the power supply. Connection between the power supply and the magnets is by multiple co-axial cable while the connection between the series connected magnets is by a single flat-strip transmission line.

DESIGN

A pulse forming network was chosen because of its ability to produce rectangular pulses of high current at modest voltages. However, using such a network to deliver a current pulse to an inductive load is a deviation from the conventional practice of using a resistive termination. While PFN's terminated with matched resistive loads have the advantage of fast rise and fall times they have the obvious disadvantage of very high power dissipation in networks of this size. If one were to terminate the PFN with an inductive load and could still achieve the desired pulse shape the energy reflected from the reactive load could be recovered, thereby greatly reducing the size

*Fermi National Accelerator Laboratory, P. O. Box 500, Batavia, Illinois 60510.

†Operated by Universities Research Association, Inc., under contract with the U. S. Department of Energy.

of the D.C. power supply used to charge the PFN as well as improving its efficiency.

To prove out such a concept, a small-scale model was constructed. This four mesh network utilized 1 μ f capacitors and hand wound adjustable inductors connected to a representative 2 μ hy load via a single 20 Arms thyristor. From this circuit it was possible to achieve the desired rectangular current pulse by careful adjustment of the PFN inductors.

The design equations applicable to PFN's were modified by the results of the test model to see if a prediction of performance could be made for a larger model. This second model, Figure 2, utilized capacitors of 240 μ f and inductors constructed from 6.4 mm diameter copper tubing, wound on a 7.5 mm diameter form. The inductance is made variable by the introduction within the bore of the coil a shorted turn in the form of a copper cylinder, insulated on its outside diameter so as not to make actual contact with the coil itself. Course adjustments of inductance are made via taps. The output is switched with a 450 Arms inverter type SCR into a 2 μ hy load, L_L . Also included is a charge recovery reactor connected via a free wheeling diode across the output end of the network.

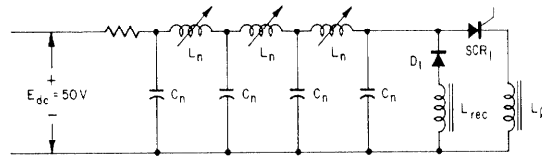

Figure 2. Test Model Schematic.

Figure 3 shows the output current and voltage waveforms of the PFN described in Figure 2. An expanded view of the flat portion at the top of the waveform is shown in Figure 4, where over a 60 μ sec interval during the flat-top, the peak-to-peak ripple current is less than .01%.

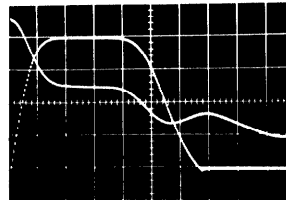

Figure 3.
I = 125 A/div.
E = 20 V/div.
t = 50 μ sec/div.

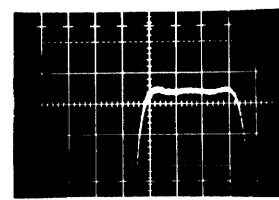

Figure 4.
I = 100 mA/div. (.025%)
t = 20 μ sec/div.

The equations empirically generated from the observed performance of the first model, and used to design the second model, are as follows:

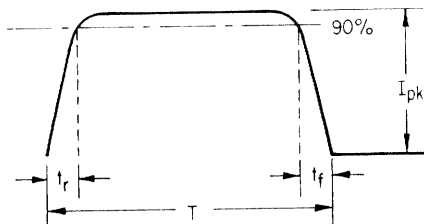

Figure 5. Pulse Parameters.

$$t_r = 2.4 (L_L C_n)^{1/2} \text{ seconds; to 90\% } I_{pk}$$

$$t_f = 1.2 t_r; \text{ from } 90\% \text{ Ipk}$$

Total pulse base width time; in seconds:
 $T = 1.77 N (L_{\ell} C_{\eta})^{1/2}$; where N = number of sections.

A close approximation of the system impedance (PFN plus load), since the final value of the variable inductors remains to be established, is given by:

$$Z_s = 0.8(L_{\ell}/C_{\eta})^{1/2} \text{ ohms.}$$

When the network has been tuned and the final values of the variable inductances are known, a more accurate value for the system impedance is given by:

$$Z_s = (L_T/C_T)^{1/2} \text{ where } L_T, \text{ in henrys, is the combined total of the PFN inductors plus the total load inductance and } C, \text{ in farads, is the total PFN capacitance.}$$

The voltage E_{Cn} to which the network capacitors must be charged is given by:

$$E_{Cn} = \text{Ipk} Z_s, \text{ VOLTS.}$$

L_{η} , the adjustable inductance, should be designed whereby:

$L_T(\text{MAX}) = 2L_{\ell}$; where L_{ℓ} is the total equivalent series load inductance as seen across the output terminals plus the stray inductance associated with the output switch. Since the co-axial line length is $\ll \frac{1}{2} \lambda$ at the frequencies involved, it is treated strictly as an inductance per unit length.

CIRCUIT

The PFN used to power the bump magnets is as shown in Figure 6. Energy is initially stored in the PFN and upon command from an external timing signal, the network is connected to the inductive load. The capacitors are of the energy storage type and are rated at 100 μfd (nominal) at 7500 Vdc; derated to 3000 Vdc operation in order to achieve a 10 year life expectancy.

The six-turn tuning coils in the PFN are constructed in a manner that permits a continuous variation of inductance from 0.1 μhy to 4 μhy . Adjustment of inductance is accomplished in an identical manner as used in the test model. By means of a mechanical lead screw the position of the shorted turn can be changed within the coil, thus changing the terminal inductance. Similar values of inductance can be obtained with different tap selections and respective readjustment of the copper cylinder core. However, the choice with the greatest core penetration will result in the lowest Q for the two cases. Low Q's result in increasing the PFN losses while yielding an output load current with minimum ripple on the flat top. If more ripple can be tolerated it may be advantageous to use higher Q configurations.

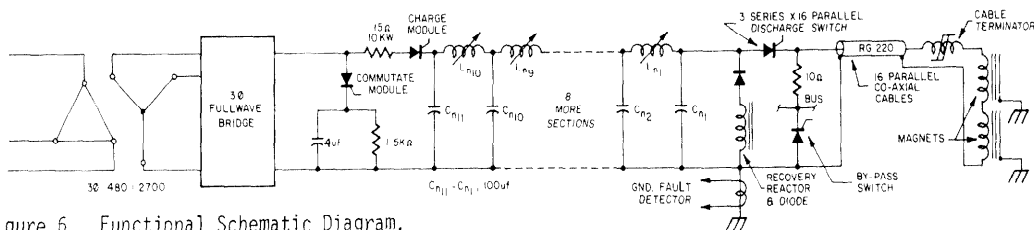
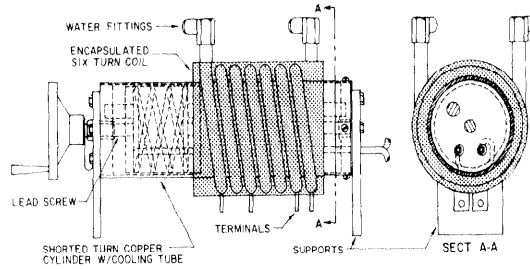

Figure 6. Functional Schematic Diagram.

A cross sectional drawing of the tuning coil is shown in Figure 7 with its parameters.



Coil	
L, min-max, μhy	.1 - 4.0
Q, 1Khz	1 - 6
Ipk, kA	40
Irms, kA	1.37
Conductor, I.D. x O.D., cm	.95 x 1.9
Winding Pitch, cm	2.54
Pitch Diameter, cm	15.06
Coil Material	OFHC Cu
Coolant Flow, ℓ/min , H ₂ O	4
Core	
Length, cm	7.62
I.D. x O.D., cm	11.75 x 12.7
Material	OFHC Cu
Coolant Flow, ℓ/min , H ₂ O	?

Figure 7. Tuning Coil Cross Section and Parameters.

The discharge switch used with the PFN consists of a series-parallel array of thyristors. Each thyristor assembly is connected from the PFN output terminal to the magnet load through matched lengths of Type RG-220 co-axial cable to provide for current sharing in the discharge switch. Thyristors selected for this application are of the accelerated gate inverter type SCR. These devices were selected and matched for their turn-on and turn-off characteristics using a test fixture duplicating the PFN operating conditions plus an additional 50% margin added to all current rating requirements.

The discharge switch assembly is rated for a working voltage of 3400 Vdc, achieved with a 60% safety margin by series connecting three thyristors whose forward and reverse blocking voltage is 1800 Vdc or greater. Static and dynamic voltage distribution between the three devices is assured by an R-C network placed across each thyristor, shown in Figure 8.

At the end of the discharge cycle the PFN has absorbed the energy reflected from the load and as a result has been charged to a reverse voltage of about 65% of the original value. This stored energy is recovered by allowing the network to discharge through a recovery reactor via a free-wheeling series string diode assembly rated for 2500 Arms, 16 kA surge and 7200 Vdc. The parameters for the recovery reactor are shown in Table I.

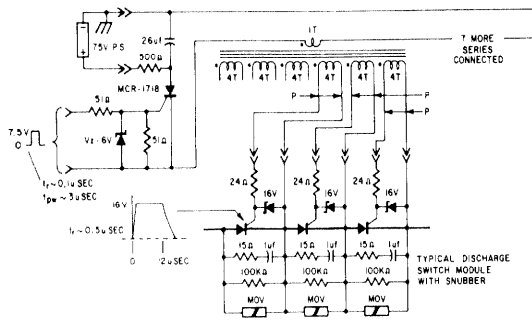

Figure 8. Firing Circuit Schematic Diagram.

TABLE I

L, μ hy	97
Q	7.5
Ipeak, kA	10.1
Irms, kA	2.12
Turns	6
Gap Height, cm	5.72
Core Material	.302 mm, Selectron
Core Weight, Kg	420

At the end of the recovery cycle, the PFN is once again of the proper polarity with approximately 58% of its original, pre-discharge, voltage. Recharging to replace energy lost during the discharge-recovery cycle is via a 3400 Vdc, 3-phase full wave bridge rectifier power supply connected through a 15 Ω , 10 kw current limiting resistor and a series SCR switch module. This switch, called the Charge Module, Figure 6, connects the D.C. power supply to the PFN when triggered by the control logic. A voltage divider across the network provides a signal for comparison with an external reference in the control logic. When the network has been recharged to the selected level, the control logic initiates conduction of the commutate module, causing a resonant charge of a 4 μ fd capacitor with the leakage inductance of the power transformer. This causes the charge module to become reverse biased and conduction ceases, terminating the charging of the network. The commutate module will self commutate once the 4 μ fd capacitor has been charged, whereupon a parallel resistor will discharge it in preparation for the next cycle. Voltage regulation achieved by this process is better than .04% when operating synchronously with the line. The commutate and charge modules, rated at 12 kVdc and 16 kVdc respectively, are made up of a series array of thyristors rated at 1 kVdc each. These thyristors were chosen for their 20 μ sec. turn-off time in order to obtain as large an operating voltage range as possible for the power supply.

Gate drive and circuit isolation for all thyristors is provided by a gate amplifier and transformer as shown in Figure 8. Six thyristors are triggered from six respective 4-turn secondary windings on each transformer. The single turn primary winding of these transformers is series connected to assure simultaneous timing of all trigger pulses to all thyristors in an array. This circuit can achieve a 1½ ampere short circuit current and an open circuit voltage of 16 volts with a current rise time of < 500 nsec.

SYSTEM LOAD AND PERFORMANCE

The sixteen individual RG-220 co-axial cables

which constitute the output transmission line from the power supply are collected at a cable termination assembly near the magnet load. Saturable magnetic material, located within the cable terminator assembly, together with an SCR by-pass switch in the power supply

form a load quenching circuit² that prevents the reverse current undershoot required to commutate the discharge switch SCR's from appearing in the magnet load. Adverse effects upon circulating beam are thus avoided.

Connection from the cable terminator to and including the series connected magnets is by a flat-strip transmission line fabricated to match the impedance of the sixteen parallel co-ax cables. The total system has an inductance of 1.524 μ hy. The contributions of individual elements are:

Magnet, each, μ hy	0.58
Cable termination (saturated), μ hy	.1
Co-axial cable (16), μ hy	.16
Strip-line, μ hy	.084
Stray, μ hy	.02

A composite oscilloscope display showing a typical load current pulse and power supply output voltage is shown in Figure 9. The system impedance is .086 ohms as it is presently tuned. Rated current can be achieved with a network impedance as high as 89 m Ω . The design repetition rate is 15 p.p.s. at a 50% repetition duty factor.

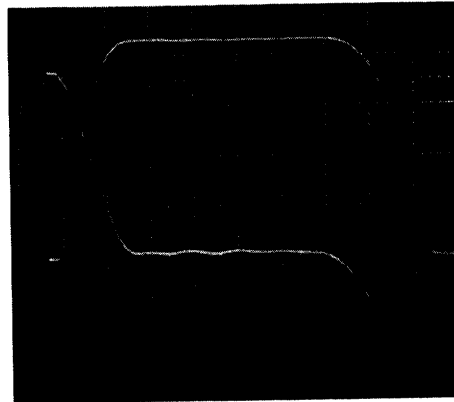

Figure 9. PFN Output Voltage and Current. Top: Load current pulse 5 kA/div. Bottom: PFN output voltage 500 V/div. Horizontal: 25 microseconds/div.

ACKNOWLEDGMENTS

The author wishes to acknowledge the participation of Steve Jachim who calculated the cooling requirements of the tuning inductors, and the technical support of James Shallenberger.

REFERENCES

1. C. Hojvat, et al., "The Multiturn Charge Exchange Injection System for the Fermilab Booster Accelerator", Session C-7, this conference.
2. R. Winje and K. Bourkland, "A 110 kA Rapid-Pulsing Power Supply", IEEE Transactions on Nuclear Science, Vol. NS-22, No. 3, June, 1975.