

## CONSTRUCTION OF ENERGY DOUBLER CORRECTION MAGNETS

F. Kircher<sup>\*</sup>, M. Leininger<sup>\*\*</sup>

### ABSTRACT

Discussed below are two types of correcting magnets currently being made at Fermilab. There are several reasons for including these correcting magnets in an accelerator: the higher order harmonics produced by large dipole and quadrupole magnets must be reduced; there is a need for vertical and horizontal steering for closed orbit correction, chromaticity correction, tune adjustment, extraction, colliding beam mode, etc.

There are four types of coils necessary to perform the functions stated above: octupole, sextupole, quadrupole, and dipole. About 180 coils of each kind are needed for the whole ring.

### I. COIL DESIGN

There are several constraints which dictate just what configurations these coils may assume. The available space between magnets for these coils is limited, which led to the idea of putting some of the coils in the bore of the main quadrupole. Unfortunately, the space in the bore of the quadrupole is also limited, making this a difficult task. Refrigeration capacity restricts the maximum current for these coils to approximately 50 amps per coil. The strength and field homogeneity of the coils must satisfy the needs of the accelerator design. The coils must be mass producible and relatively inexpensive. The coils must not adversely affect quench properties of the main quad.

All of these factors have resulted in coils of the following configuration. The octupole, sextupole, and dipole coils have been combined into a magnet called the long correction package (LCP). This correction package is wound directly on the beam tube, 73.0 mm O.D. (2-7/8"), which fits inside the bore of the main quadrupole magnet. The correction package is 1.78 m (70") long, and approximately 5 mm (3/16") thick. The quadrupole correcting magnet is called the long trim quadrupole (LQT) and is located external to the main quadrupole rather than in the bore because of field coupling.

### II. TRIM QUADRUPOLE

#### Design Details and Construction

Figure 1 shows a typical cross section of LQT. It consists of four individual coils impregnated in stycast 2850 FT using Catalyst 11. The bore of LQT is 103 mm (4-1/16"). It is surrounded by an iron shell of 12.7 mm (1/2") wall thickness for an overall diameter of 140 mm (5-1/2") and a length of 257 mm (10-1/8").

The coils are made from Nb-Ti superconducting wire, .41 mm (.016") bare conductor diameter, coated with two layers of insulation and an outer coating of thermoplastic for self bonding when exposed to heat. The final wire size is .50 mm (.0195"). Five hundred turns of wire are wound on a rocking mandrel using a two piece key. The winding machine is shown in Fig. 2. Upon completing the winding, the edges of the coil are constrained straight and true using an edge compressor. This insures that all coils are uniform

\* On leave from CEN SAACLAY

\*\* Fermi National Accelerator Laboratory, operated by Universities Research, Inc., under contract with the Department of Energy.

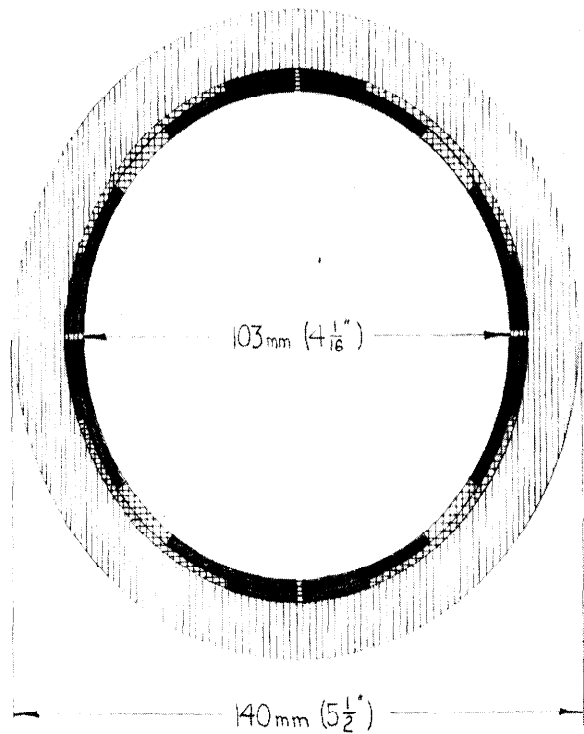

Fig. 1: LQT Cross Section

in size. The coil, now rigidly held in the tooling, is placed in an oven and baked at 180°C (350°F) for one hour to achieve bonding of the wire. When sufficiently cool, the coil is removed from the tooling and becomes self supporting due to the bonding of the thermoplastic.

Four of these coils are mounted on an aluminum mandrel, spliced together, and wrapped with fiberglass tape. This assembly is then slid inside a piece of

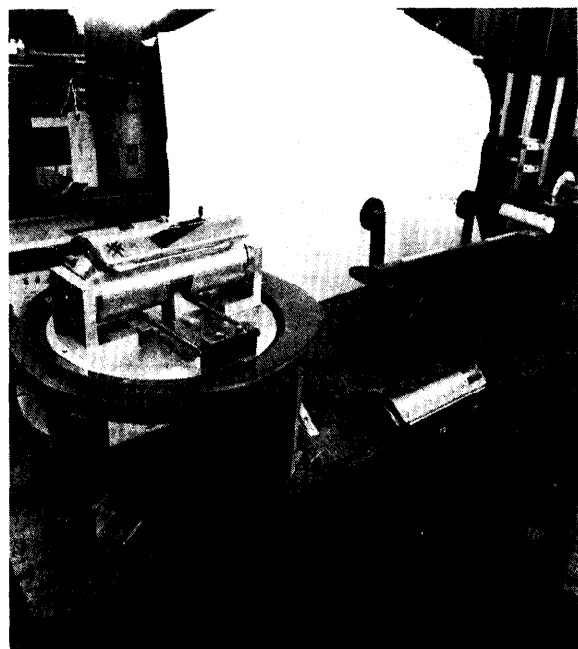

FIG. 2: LQT Winding Machine

steel tubing, the ends sealed with vacuum flanges creating a vacuum tight annulus containing all four coils. Stycast epoxy is then vacuum drawn into this annulus, resulting in the four coils being completely impregnated. The aluminum mandrel is pressed out after the epoxy cures, leaving the four coils surrounded by the steel tube.

### Experimental Results

The LQT package was preceded by a short trim quad (QT) 152 mm (6") long, 76 mm (3") bore size, each coil made with 250 turns. Several QT's and one LQT has been tested.

The quench behavior of the coils is very similar: The coils show some training, (first quench typically around 55% of the critical current) reaching about 85% of the critical current after a few quenches, see Fig. 3. During the construction of several coils,

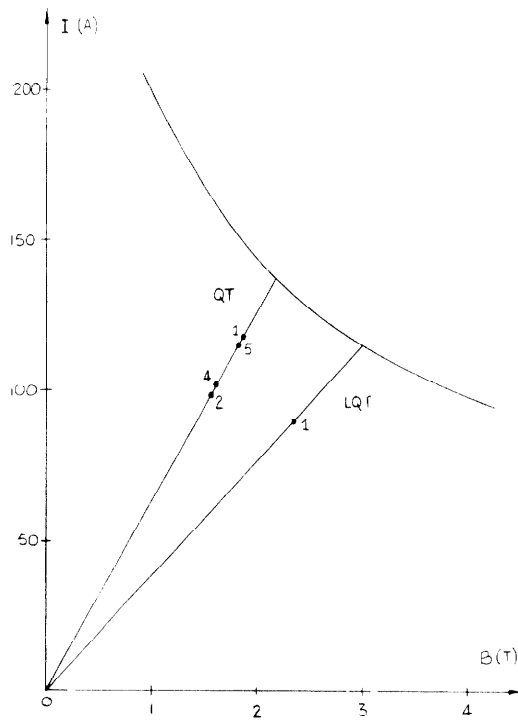

Fig. 3: Maximum Current for QT, LQT

pressure (2 kg/cm<sup>2</sup> = 28 psi) was used after the vacuum impregnation in an attempt to fill any voids. This pressure always caused significant increases in training and the use of pressure was abandoned.

The coil is self protected up to its maximum current; i.e., its internal resistance is growing fast enough to get a quick current decay in case of a quench.

Magnetic measurements show a magnetic length of about 188 mm (7.4") for LQT. The nominal strength of .132 Tm (52 KG inch) at 2.54 cm (1") is reached at a current of 71 A.

The magnetic inhomogeneity is so far dominated by the 12 P (the body is designed to cancel it, but no corrections have been made so far in the key angles to cancel the integral field).

### III. LONG CORRECTION PACKAGE (LCP)

#### Design Details and Construction

Figure 4 is an assembly drawing of LCP. It consists of an octupole, sextupole, and dipole element wound directly on the beam tube. All elements are

wound directly on the beam tube. All elements are wound with the same wire used for LQT. The coils are wound pancake style between two flat plates in a single layer (see Fig. 5) then baked at 180°C (350°F)

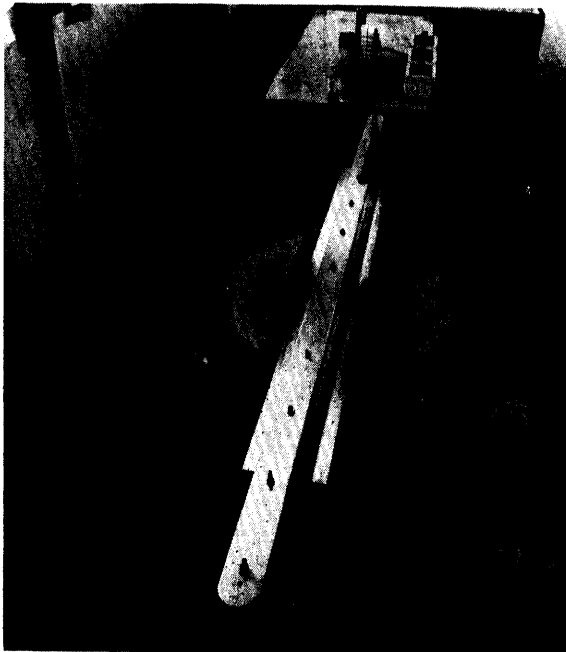

Fig. 5: Winding Machine

for one hour. After cooling, the flat coils can be removed from the tooling plates. The coils are stacked in pairs, the inner leads spliced, and the pair taped together with Kapton tape to make an assembly. The octupole coil pairs are mounted on the beam tube, being located by stainless steel keys. The outer leads of the coil are spliced, power leads brought out and G-10 CR keys mounted between coils. G-10 CR saddles are mounted at each end of the coils. The coil, saddle, key assembly is single layer butt wrapped with Kapton tape. The sextupole coils are treated the same way, being mounted directly on top of the octupole coils and wrapped with Kapton. The dipole coils are then mounted on top of the sextupole coils. Both vertical and horizontal steering dipoles are being made with normal octupole and sextupole configurations used in each case. The finished assembly is spiral banded with 9.5 mm x .8 mm (3/8" x 1/32") aluminum.

Having chosen the key angles to cancel the first allowed harmonic, the magnetic field produced by such a coil is:

$$B_N = \mu_0 J_0 \Delta R \frac{\sqrt{3}}{\pi} \left( \frac{r}{R} \right)^{N-1}$$

Where

$B_N$  is the radial component

$N$  = half number of poles ( $N = 1$  for dipole)

$J_0$  = mean current density

$\Delta R$  = thickness of the coil

$r$  = point coordinate

$R$  = coil inner radius

Assuming that  $N_T$  is the number of turns per sector,

for a two layer coil:

$$B_N = 6 \sqrt{\frac{3}{\pi^2}} \mu_0 \frac{NN_T I}{R} \left( \frac{r}{R} \right)^{N-1}$$

Assuming a nominal current of 50 A and a magnetic length of 1.68 m (66") the integrated strength of the coils at 2.54 cm (1") is:

- .073 Tm (28.6 KG in) for the octupole
- .110 Tm (43.5 KG in) for the sextupole
- .249 Tm (98.2 KG in) for the dipole

Experimental Results

Three LCP's have been tested so far in different conditions:

LCP 1: With banding, alone

LCP 2: Without banding, inside a quadrupole (QB 6). This test has shown the necessity of a strong banding.

LCP 3: With aluminum banding, inside a quadrupole (QB 7). The results obtained with this package are reported here.

Training and degradation (Fig. 6): The coils show some training, which is not so serious as there is an improvement in the current after each quench. The degradation which affects the coil (mostly the dipole) as the external field is increased is more prejudicial. However, the nominal current of 50 A with the nominal external field is reached almost without training, and the dipole, which seems to be the most sensitive coil, has been pulsed up to 55 A at 10 A/sec. for some time without trouble.

Protection: The dipole is the coil with the largest inductance (~ 100 mH). It is self protected in case of quench because of the growth of its internal resistance. A quench of a correction coil does not induce a quench in the main quadrupole at its nominal current.

IV. CONCLUSION

Because the Energy Doubler design is still under discussion, it is not certain whether the final design of the correction elements will be exactly as de-

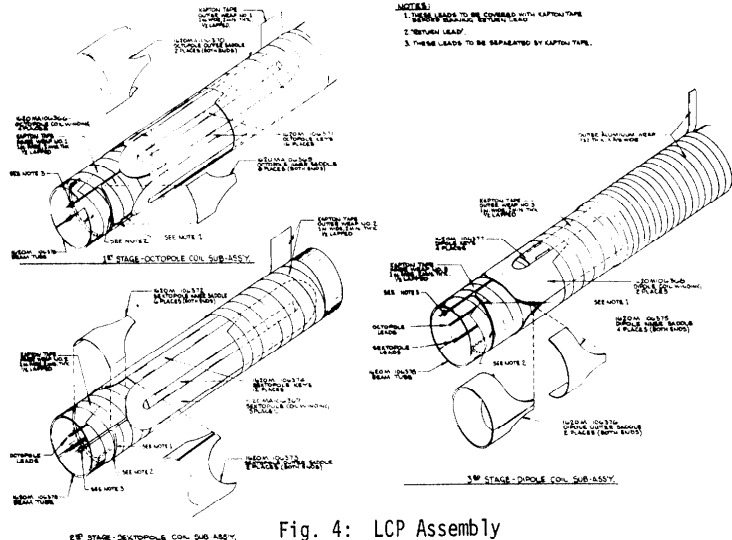

Fig. 4: LCP Assembly

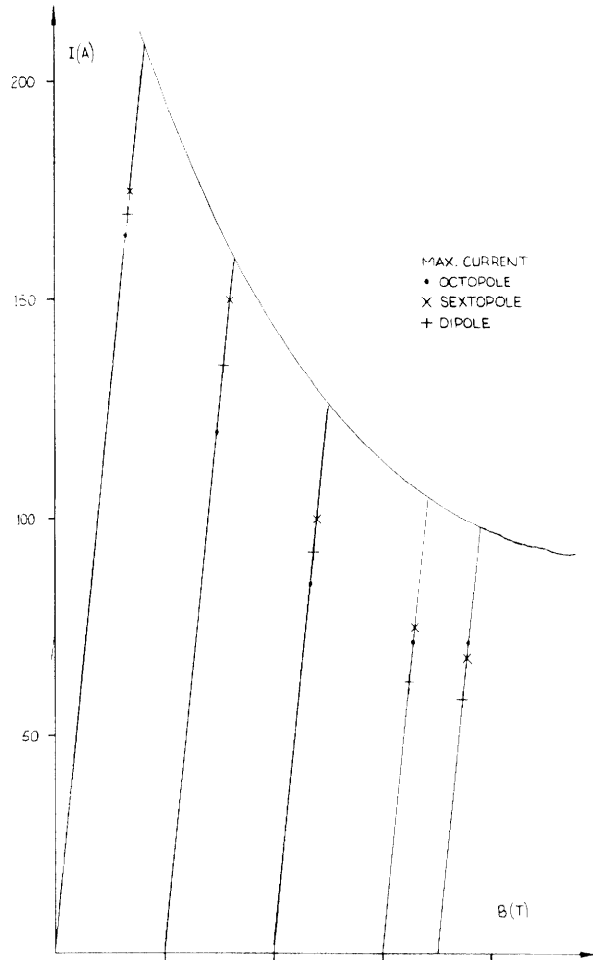

Fig. 6: Maximum Current For LCP

scribed in this paper. The work done so far does show that it is possible to make the required correction elements in a rather simple way, even though some improvements are needed.

V. ACKNOWLEDGEMENTS

The authors are grateful to all the people who have been involved in the work on these correction elements, including the initial concept, design, engineering, production and testing of the final magnets.