

THE DESIGN, CONSTRUCTION, AND OPERATION UPDATE OF THE ISABELLE RING MAGNETS\*

A.D. McInturff, E. Bleser, D. Brown, J. Cullen, P. Dahl, D. Gardner,  
 D. Kassner, J. Kaugerts, K. Robins, W. Sampson, P. Schewe, W. Velia†

Abstract

This report updates the various designs and prototypes tested since the last Conference. Included are the operational data of a subassembly of the old 200 x 200 GeV machine design as well as the latest larger prototype ring magnets with their strong points and shortcomings. The working line coil system design presently seems to be nearly completed, having gone through major revisions to increase its possible operational range. One of the major design goals of the magnet series, that of each unit being able to absorb their own energy, seems to be well in hand. This feature enables the magnet string to be protected without external intervention, i.e., without external energy dump or driving the magnet winding normal by an active external circuit. Simply stated, this means that the magnet's L/R time constants during quench are short enough to prevent thermal damage. There are two series of prototypes. The first type is the so called "Standard" which will become the ring magnet for ISABELLE. The second is that in which various characteristics and/or limits of various parameters are explored. Various parameters such as specific heat of the windings, increased metal packing fractions, and resistivity of turns (in the normal state) are bracketed. The 400 x 400 GeV version of ISABELLE<sup>1</sup> requires a cold aperture of 13.09 cm, quadrupole magnetic length of 1.6 m, and dipole length of 4.65 m at a peak dipole field of 5.0 T. Two machine size dipoles and one quadrupole are being presently tested.

Introduction

The operation of magnets at high magnetic field (i.e., high current) for long periods is an ideal application for superconductivity. The cyclic nature of superconductor losses is an advantage with respect to the low duty factor of a storage ring. The much higher magnetic fields attainable due to the increased coil current density results in a reduced physical size of the machine for a given peak energy, therefore making the device more economical to build and operate. These high field superconducting magnets have the characteristic that the quality of the field is dependent upon the conductor placement accuracy, i.e., as in the case of an aircore magnet, and the surrounding iron shield acts only as a mirror image of the conductors and is not the major field shaping element as in more conventional room temperature magnets. Due to the million ampere-turn current and extremely high magnetic fields, there are enormous coil forces present which must be constrained to less than 0.3 mm in the azimuthal and radial direction, and less than 1 mm in the longitudinal direction. In a device that has a stored energy in excess of 1 megajoule, there is an interesting constraint due to the nature of superconductivity and specific heats of materials at these low temperatures. A release of thermal energy of as little as a few millijoules can cause the magnet winding to become unstable and switch to the normal state, therefore, presenting the designer with an interesting engineering problem. The latest evaluation of the magnets needed for ISABELLE are presented here, with their attributes and detriments discussed.

Magnet Design

An ISABELLE ring magnet can be simply described as a pair of single layer saddle coils with a cosine

( $n\theta$ ) turn distribution that are preloaded and restrained by a cold iron shield which serves as the inner dewar vessel as well. The typical winding cross sections are shown in Figs. 1 and 2.

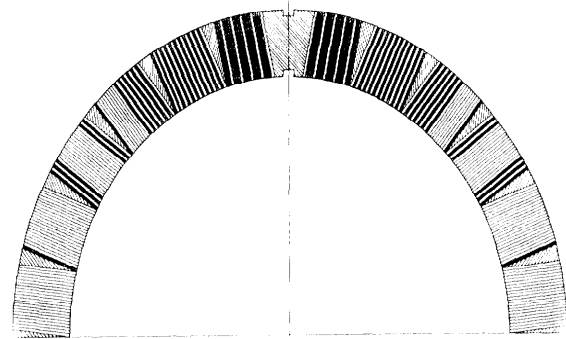

Fig. 1. The turns distribution utilized in the standard ring magnet dipole. One pole is shown here.

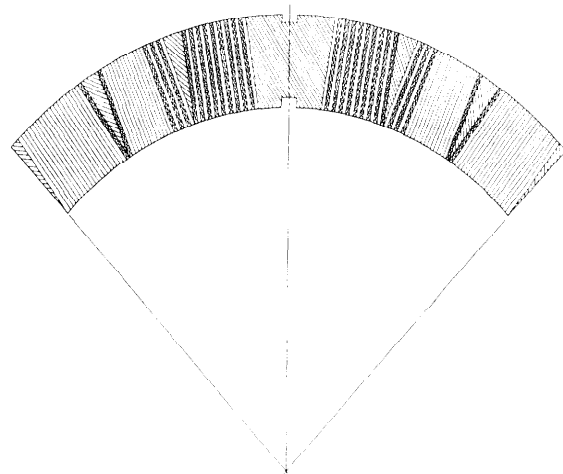

Fig. 2. The turns distribution utilized in the standard ring magnet quadrupole. One pole is shown.

These windings are constructed using a hydraulically clamped fixture operating at elevated temperature, as shown in Fig. 3. The actual construction details and techniques have been covered in previous papers.<sup>2-4</sup>

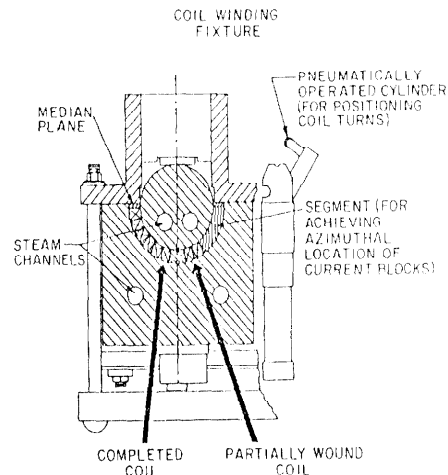

Fig. 3. This is an end-view drawing (axial) of the steam heated, hydraulically loaded iron winding fixture used for the ISABELLE coils.

\*Work performed under the auspices of the U.S. Department of Energy.

†Brookhaven National Laboratory, Upton, NY 11973.

The peak magnet demand during the construction of ISABELLE will require eight dipole fixtures and two quadrupole fixtures which are presently under construction. They will be capable of producing a magnet a day. This should enable a production of 250 sets of magnet windings in the course of a calendar year.

Important design parameters that were discussed in the prototype program can be divided roughly into two categories: material properties and magnetic properties. One of the more important material characteristics is the compatibility of the materials in the coil winding package during the cool-down cycle from room temperature to operating (4 K) temperature. Another important feature is the ability to withstand the large compressive forces encountered at both ends of the temperature range. The compressive load of the interface fit between the iron core and the magnet windings is maximum when both coil and iron are at room temperature after the insertion of the coil. The magnetic load is maximum at the system operating temperature (4 K). Another problem appeared during the elevated temperature cure cycle of the "B" stage epoxy resin used on the coil package itself. In order to increase the modulus of the coil and reduce the shrinkage coefficient, i.e., to achieve increased compatibility of the iron core and the windings at 4K during the cure cycle, (140°C) the windings are subjected to high pressure until they reach proper size. This combination of high temperature and pressure created problems in the choice of the post and wedge materials (the original materials had deformation temperatures less than 100°C) essentially the impossible requirement of trying to obtain 0.1 millimeter tolerances with gelatin. Another mechanical property of importance for stability is as high a modulus as possible for the winding. The most important magnetic properties required are: predictability and reproducibility of the magnetic field shapes with the ability to alter those shapes as required for machine operation, and, the ability to achieve the highest reliable magnetic field intensity possible within the economic constraints given. The materials that have evolved as well as the winding and molding techniques used in conjunction with the containment of the coil structure by the iron shield has resulted in a design that nominally results in magnets which achieve the following desired properties:

1. The quench characteristics of the magnet are such that there are no thermomechanical distortions of the turns when all of the stored energy of the device is internally dissipated. The high azimuthal quench velocity (turn-to-turn) causes the energy to be distributed over a large volume of the coil. The high velocity is a result of the following three conditions being met: a) There are no epoxy or thermoplastics from the pole tip to the midplane wedge on the inner diameter edge of the coil with the exception of the turn-to-turn fiberglass epoxy insulation tape. b) The fiberglass epoxy insulation tape is very thin and has a very high glass to resin ratio (see Fig. 4). c) The high aspect ratio of the conductor (width to thickness  $\sim 23/1$ ) results in a large conductor surface area to volume ratio. One-seventh of the azimuthal path of the inner diameter of the coil from the first current block to the midplane is occupied by fiberglass and "B" stage epoxy, and the rest is metal.

An interesting feature of the magnets is that they reach a maximum coil temperature at a field below the peak achievable field. This feature is true even if the quench is treated adiabatically and not transformer coupled with the iron core. Figure 5 shows a plot of  $\alpha I^2 dt$  and peak temperature for ISABELLE prototype ISA MK-XIV, both calculated and measured. Note at the high field end the magnetic field couples the iron core due to the very large  $\dot{B}$ , i.e. 30.0 T/sec.

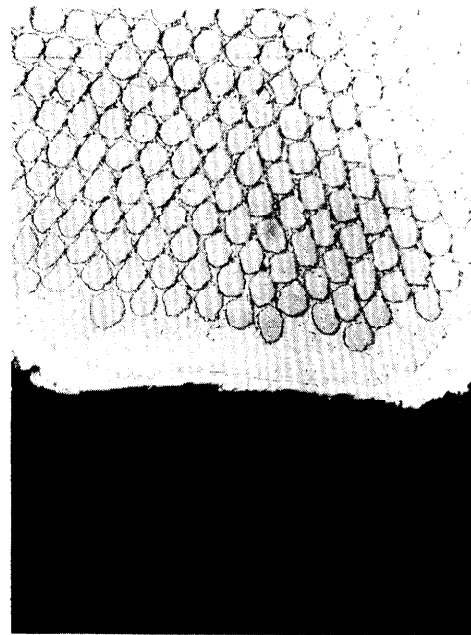

Fig. 4. Magnet braid to braid enlargement showing glass fibers and the multifilament superconductor

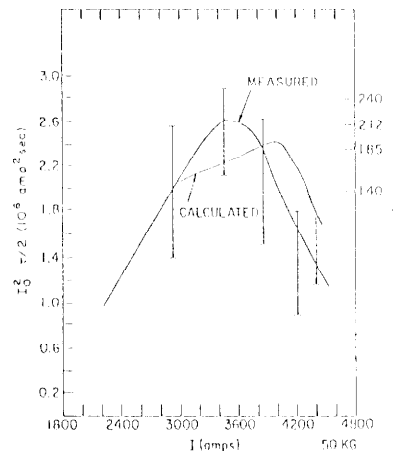

Fig. 5. The maximum coil temperature is plotted on the right hand side of the peak temperature in the coil if the quench initiates in a high current density region. This is a plot of data obtained from ISA MK-XIV.

- ii. The coil package is restrained radially and azimuthally by the interference fit in the iron shield. This is accomplished by inserting the coil package at 77 K into the laminated room temperature iron shield. This preload, if all of the components fill the radial extent of the coil package, results in the magnet reaching short sample performance of the conductor with a minimal of training.

The parameters that have been explored in the experimental series are shown in the following list and will be referred to by number in the section on results.

1. The transfer function of the magnet has been increased. The dipole function from 12.5 g/A to 13.5 g/A.
2. The current density available in the basic conductor has been increased by about 5%.
3. The effective current density at  $10^{-12} \Omega\text{-cm}$  effective resistivity of the winding has been increased, as well as the quench current.

4. The effective resistivity of some components of the magnet winding has been increased. This is to increase the quench propagation and decrease the B dependence of various magnet parameters.

5. Better mechanical control of the materials that compose the coil package has been achieved.

6. Better saturation parameters of the iron shield, due to geometry, has been achieved.

7. The effective resistivity of some part of the winding has been decreased. This is to improve stability and thermal conductivity.

The various experimental and standard magnets have led to the present designs which are shown in Figs. 1 and 2. The design of the double layer magnet is essentially identical with that of the single layer except one magnet winding nests inside the other. The inner layer is wound first, then banded and the outer layer is clamped onto the inner magnet's outer bands. The crossover joints (i.e., where the two halves of a coil layer are electrically connected by a lapjoint) were made external to the outside coil, for both coil layers.

#### Magnet and Magnet Systems Performance

The parameters of the experimental series of prototype magnets have varied considerably, as has the performance. The standard magnet series represents a compromise based on parameters that yield the most reliable performance economically. The performance and characteristics of both series of magnets, including those of several full size standard quadrupoles, have been summarized in considerable detail at the Applied Superconductivity Conference in Pittsburgh in September 1978. Recently the injection and ejection schemes plus several other beam considerations have necessitated an increase in aperture from 12.154 cm to 13.09 cm in the standard series. The most recent experimental prototype dipole tested, MK-XIV, exceeded the design field of 5.0 T, reaching a maximum field after considerable training (44 quenches) of 5.1 T (representing approximately 97% of short sample performance). Training is defined as a superconducting to normal transition of a magnet at a lower current than the device is potentially capable of, with an increase in the current attained upon each successive transition.

In Table I the parameters for the new preproduction ring magnets and ISA MK-XIV are listed.

The Half-Cell series test was performed to gain experience in the proposed series operation of the magnets, both cryogenically and electrically. The Half-Cell was that of the older 200 x 200 GeV version of the ISABELLE lattice consisting of two dipoles and a quadrupole (MK-II, V, and QUAD I). In the forced flow system, high pressure helium gas entered the first dipole (MK-II) and passed through to the second dipole (MK-V) and then went on to quadrupole (QUAD I) before returning to the refrigerator via the intermediate shields which enclosed each magnet.<sup>5</sup> The superconducting interconnections for the main and working line coil system were routed through the high pressure helium gas lines from coil to coil. The iron core laminations and the stainless steel tube that held them also served as the high pressure vessel and inner dewar. This standard Half-Cell structure would be repeated 108 times in the 400 x 400 GeV lattice with the exception of 3 dipoles, not 2, per Half-Cell. The quench protection for this prototype Half-Cell was based on a combination of relief valves on both sides of the quenching magnet and a cold diode across the magnet's terminals in order to limit the forward

Table I. ISABELLE Magnet Parameters

	Experimental				
	Double Layer	XIV	Preproduction 0001 <sup>a</sup>	Preproduction 0002 <sup>a</sup>	Quad 3001
Field (T) <sup>b</sup>	6.0	5.0	5.0	5.0	4.7
B/I (mT/A)	2.23	1.25	1.35	1.35	1.14
B(0,0) <sub>max</sub> (reached)	6.2	5.17	4.2		
1st Quench	4.96	3.2	3.6		3.9
# Quenches	24	56	26		
1.d. cm	8.5	12.2	13.1	13.1	13.1
<b>% Short Sample</b>					
1st Quench	73	58	60		72
High quench	97	97	72		
<b>Current Density</b>					
"J" kA/cm <sup>2</sup>					
Incl. Ins. <sup>b</sup>	21.9	34.1	35.4	35.4	35.4
Conductor <sup>e</sup>	26.7	39.3	41.3	41.3	41.3
Max Achieved	29.2	44.4	34.5		
Parameters <sup>c</sup>	BNL <sup>d</sup>	BNL <sup>d</sup>	Westinghouse <sup>d</sup>		
Varied	6	2.7	std.		
<b>Harmonic (J.2 T)</b>					
b <sub>2</sub> × 10 <sup>4</sup> cm <sup>-2</sup>	-0.8	-0.25	3.4		x10 <sup>3</sup>
b <sub>4</sub> × 10 <sup>6</sup> cm <sup>-4</sup>	17.0	1.6	1.25		b <sub>5</sub> 1.8
Grad. mT/cm (max)					b <sub>7</sub>
Energy Dissipated (MJ)	0.22	0.77	0.65		Max 7.0
Mag. Length (m)	99	402	461		160
10 K Res. (mΩ)	105	272	290		
Induct. "L" (mH)	48	77	120		
<b>Time Const. 1/e</b>					
Magnetization	38	37	37		37
sec					
Quench (L/R) <sup>e</sup>	0.4	0.16	0.5		
Loss ISA φ W/m	-	-	-		-
Ref. Mode	Pool	Pool	Pool		Pool
Damaged	N	N	N		N

a) tests not completed yet; b) design; c) these numbers explained in design section; d) coil fabricator; e) 1/e current decay time with 5 mΩ across magnet terminals during a quench.

voltage.<sup>6</sup> The purpose of the relief valves is twofold. First, it reduces the pressure of the hot gas wave that is generated in the quenching magnet, and second it assures a high enough mass flow past the interconnecting bus, in the case of two or more magnets in series simultaneously quenching, to prevent it from being damaged. The cold diode virtually eliminates external energy from being dumped into the quenched coil. This magnet array had external leads connected to the intermagnet buses, in case the cold diode scheme proved unworkable. These leads, however, had very high losses and therefore limited the lowest temperature attainable. The system reached a temperature of 5.5 K at the warmest magnet. The quench current at this temperature was 3.5 kA which corresponds to a dipole field of 4.3 T. The system was operated for a period of five weeks without accidental quenching. The quench protection scheme (i.e. cold diodes and relief valves) worked exceptionally well on the scheduled quenches. In all but two transitions of the magnets to the normal state, the transition was confined to the initiating magnet, and in those cases where it was not, the succeeding magnets were at a much lower power level by the time they reverted to the normal state.

There is presently under construction a pre-construction cell which will use the Westinghouse produced main windings and BNL produced working line coil systems. This system should become operational by late fall. This is a standard cell for ISABELLE containing 6 dipoles and 2 quadrupoles. This system will employ the protection scheme described above, based on cold diodes and pressure relief valves.

Mechanical Data and Errors Analysis of Westinghouse  
Preproduction Magnet Series

A mechanical analysis of the first 6 poles completed for the new size ring magnets may be summarized as follows:

	Midplane Depth	Post Radius
Design	0.244"	2.8275"
Measured	0.242 <sup>+0.004"</sup> <sub>-0.005"</sub>	2.830 <sup>+0.005"</sup> <sub>-0.007"</sub>
Expected	0.250"	2.8275"

The average difference between the design value and the expected value is due to the different expansion coefficient of the newer high density coils. The radial size increase was due to a change in material and to the size of the post mold being designed for 25°C and the post being cured at 145°C. This size difference accounts for the increase in  $b_2$  from the computer design value of  $290 \times 10^{-6}/\text{cm}^2$  to the measured value of  $530 \times 10^{-6}/\text{cm}^2$  in 0001. If we compare two or more magnets with one another of the Westinghouse series it is possible to estimate the random error. The early mechanical measurements indicate a random error of  $60 \times 10^{-6}/\text{cm}^2$ , which is

about eight times higher than the desired goal of  $8 \times 10^{-6}/\text{cm}^2$  for the rms error.

Acknowledgements

The authors would like at this time to acknowledge the skill and dedication of the ISABELLE technicians and the various BNL shops.

References

1. ISABELLE, A Proton-Proton Colliding Beam Facility, BNL Rept. 50648 (1977).
2. A.D. McInturff, P.F. Dahl, R. Damm, C. Lasky, K.E. Robins, and W.B. Sampson, IEEE Trans. Nucl. Sci. NS-22, No. 3, 1133 (1975).
3. A.D. McInturff, W.B. Sampson, K.E. Robins, P.F. Dahl, and R. Damm, IEEE Trans. Nucl. Sci. NS-24, No. 3, 1242 (1977).
4. W.B. Sampson, K.E. Robins, S. Kiss, P.F. Dahl, and A.D. McInturff, IEEE Trans. Nucl. Sci. NS-24, No. 3, 1296 (1977).
5. J.A. Bamberger, J. Aggus, D.P. Brown, D.A. Kassner, J.H. Sondericker, and T.R. Strobridge, IEEE Trans. Magnetics MAG-13, No. 1, 696 (1977).
6. K.E. Robins, W.B. Sampson, and M.G. Thomas, IEEE Trans. Nucl. Sci. NS-24, No. 3, 1318 (1977).