

DESIGN OF THE ACCELERATING STRUCTURES FOR FMIT\*

D. Liska, R. Schamaun, C. Potter,† C. Fuller, D. Clark, D. Greenwood, and J. Frank†  
Los Alamos Scientific Laboratory, Los Alamos, NM 87545

Abstract

Design considerations and concepts are presented for the accelerating structures for the Fusion Materials Irradiation Test (FMIT) Facility. These structures consist of three major units: a 0.1- to 2-MeV radio-frequency quadrupole based on the Russian concept, a 2- to 35-MeV drift-tube linac made up of two separate tanks designed to generate either 20- or 35-MeV beams, and an energy dispersion cavity capable of spreading the energy of the beam slightly to ease thermal loading in the target. Because of probable beam activation, the drift-tube linac is designed so that alignment and maintenance do not require manned entry into the tanks. This conservatism also led to the choice of a conventional vacuum system and has influenced the choice of many of the rf interface components. The high-powered FMIT machine is very heavily beam loaded and delivers a 100-mA continuous duty deuteron beam to a flowing liquid lithium target. The power on target is 3.5 MW deposited in a 1 x 3 cm spot. Because of the critical importance of the low energy section of this accelerator on beam spill in the machine, a 5-MeV prototype will be constructed and tested at the Los Alamos Scientific Laboratory (LASL).

Introduction

The FMIT Facility will assist in the ultimate achievement of commercial fusion power by providing an intense source of 14.1-MeV neutrons for first-wall

\*Work supported by the U. S. Department of Energy.  
†Westinghouse-Hanford, P. O. Box 1970, Richland, WA 99352, HEDL employees working at the Los Alamos Scientific Laboratory.

materials damage and materials development studies.<sup>1,2</sup> The high neutron flux-volume ( $10^{15}$  n/s-cm<sup>2</sup> in 10 cm<sup>3</sup>) is to be achieved with an accelerator of unprecedented continuous duty power and beam intensity, designed for a functional life of 20 years. A 100-mA cw deuteron beam will be fired at either 20 or 35 MeV into a rapidly flowing liquid lithium target that must be exposed directly to the beam without the aid of an isolation window. A plan view of the accelerator and its beam transport system is shown in Fig. 1.

Fundamental choices in operating parameters for FMIT are low injection energy (100 keV) and a relatively high 80-MHz rf frequency.<sup>3</sup> To reduce loss of the high-intensity beam, the bore of the drift-tube linac is made as large as practical (8-cm diam maximum) and design of the first drift-tube is made considerably easier by injecting the beam at 2 MeV instead of the more conventional 500 keV (this increases beta-lambda to 17.3 cm vs 8.7 cm). Higher injection energy is accomplished using a unique rf quadrupole structure (RFQ) that efficiently accepts the low-emittance beam from the 100-keV injector. The RFQ captures essentially all the beam at these low energies and focuses it with rf fields. The RFQ then phase-bunches the beam at 80 MHz and accelerates it to 2 MeV for injection into the drift-tube linac. The RFQ was adapted from the Russian design.<sup>4,5</sup>

The high-energy beam transport (HEBT) system carries on the periodic focusing sequence of the machine and it can deliver the beam to either of two target cells through achromatic bends.<sup>6</sup> To spread the beam energy to prevent overheating the lithium target caused by energy deposition at the Bragg peak, it is necessary to provide an energy dispersion rf

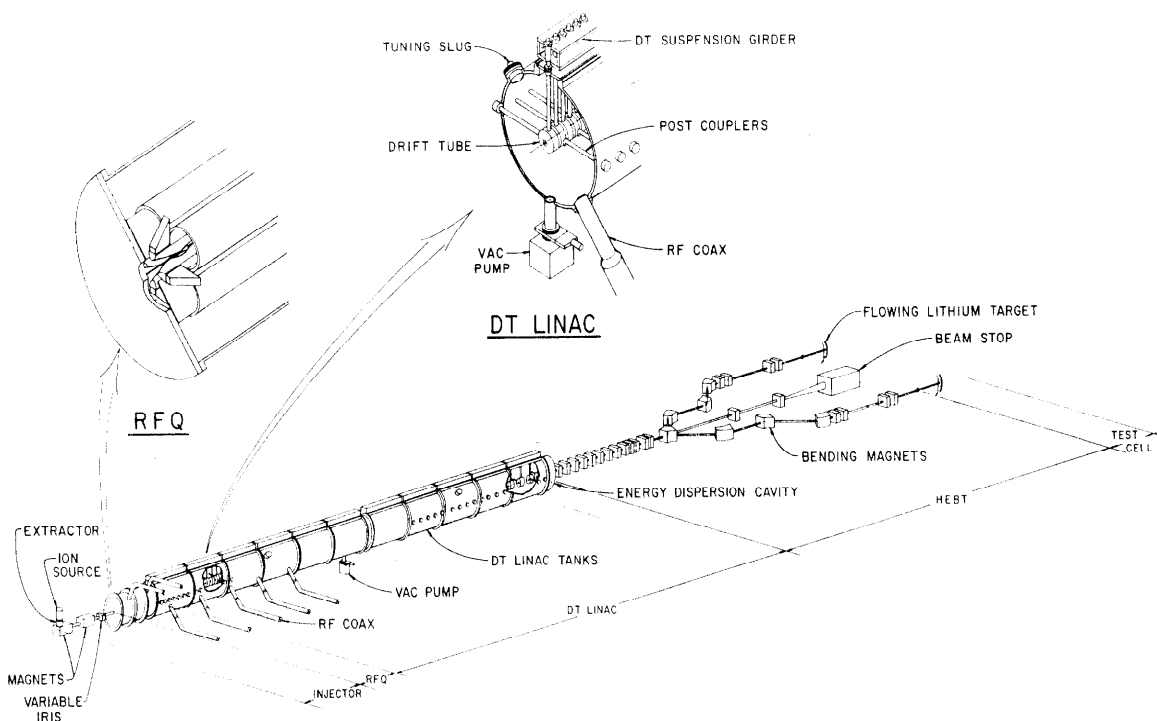

Fig. 1. Overall layout of the FMIT accelerator and beam transport system.

cavity at the output of the drift-tube linac. This cavity resembles the last linac cell and operates at 79 MHz so that the energy dispersion of the beam varies with a 1-MHz beat relative to the fundamental accelerator frequency.

### Discussion

The FMIT accelerating structures are computer designed to achieve optimum beam dynamics and high accelerator efficiency. Careful code design is especially important in developing the RFQ because of its unconventional and untested nature. The cavity design code SUPERFISH was used on the RFQ despite lack of rotational symmetry about the beam axis by studying the structure as a toroid of extremely large radius. This simplification allowed the TE<sub>210</sub> quadrupole rf mode to be established. Acceleration is achieved through longitudinal fringing fields so that vane tips must be formed into aperiodic, phase-shifted arrays. To assure proper field distributions and beam dynamics through this structure, both SUPERFISH and the beam dynamics code PARMILA were used.<sup>7</sup> The RFQ is still in its modeling stages and no specific designs of the full-powered structure have yet been made. Because of the high mechanical precision required in the vanes at the small aperture that will be used, special fabrication techniques such as electroforming and copper plating are being considered. A full power proof-of-principle test of this structure will be conducted at 440 MHz prior to designing the full size 80-MHz RFQ for the 5-MeV LASL prototype.

The drift-tube linac consists of two continuous tank sections, 18- and 15-m long, joined by an inter-tank spacer. The tanks are driven by 7 and 6 high-powered rf coupling loops, respectively, each capable of delivering 500 kW cw at 80 MHz. Because the rf systems for each tank are independent, the downstream tank can be shut down when a 20-MeV beam is required. Diagnostics are located in the intertank spacer that is one beta-lambda in length (54.3 cm at 20 MeV). The tanks will be fabricated of 2.5-cm-thick copper clad steel surrounded by a continuous steel shell jacket

for longitudinal counterflow flood cooling. Other fabrication techniques using copper plating were rejected because we lacked confidence that the necessary quality could be achieved in industry within the required schedule time. Of primary concern in designing the tank structure is the expectation of high activation levels caused by beam spill in the drift-tube bores. The Russian version of this facility assumes an average distributed beam spill of about 10  $\mu$ A/m and they plan to use remote handling methods for maintenance.<sup>8</sup> The LASL design assumes 3  $\mu$ A/m plus "hot spots" and uses the philosophy that maintenance should be adaptable to mechanically-assisted or "long-handled" techniques so that a man should never be required to enter the tanks. This design philosophy led to adaptation of the girder-strongback drift-tube suspension concept illustrated in Fig. 2. The great advantage of this technique is its capacity for accurately aligning the drift tubes on a given girder before installation in the tanks and then aligning each girder relative to the others by methods involving only external measurements. Each girder is about 3-m long, weighs about 3000 kg and carries from 3 to 14 drift tubes. A total of 11 girders is planned.

This girder suspension concept resembles that used on the CERN linac except that the girder-strongbacks are supported by the tank stiffening rings and not by the vacuum sealing surfaces as is done at CERN. This method eliminates the warp that might be induced in the girders when the FMIT tanks are evacuated or powered. Unlike the CERN girder-strongback, the LASL design incorporates a separable spanner hatch cover that provides the vacuum and rf seals as well as bridging and strengthening the tank slot. The spanner does not bear directly against the drift-tube stems and thus slot warpage caused by vacuum or thermal pressures on the tank cannot effect the drift-tube alignment. The only pressures acting on the stems are applied by the bellows that form the vacuum seal between the spanner and the stems and these forces are relatively small and directed principally along the stems. Thus, the gross alignments of the girders relative to one another are affected only by warpage

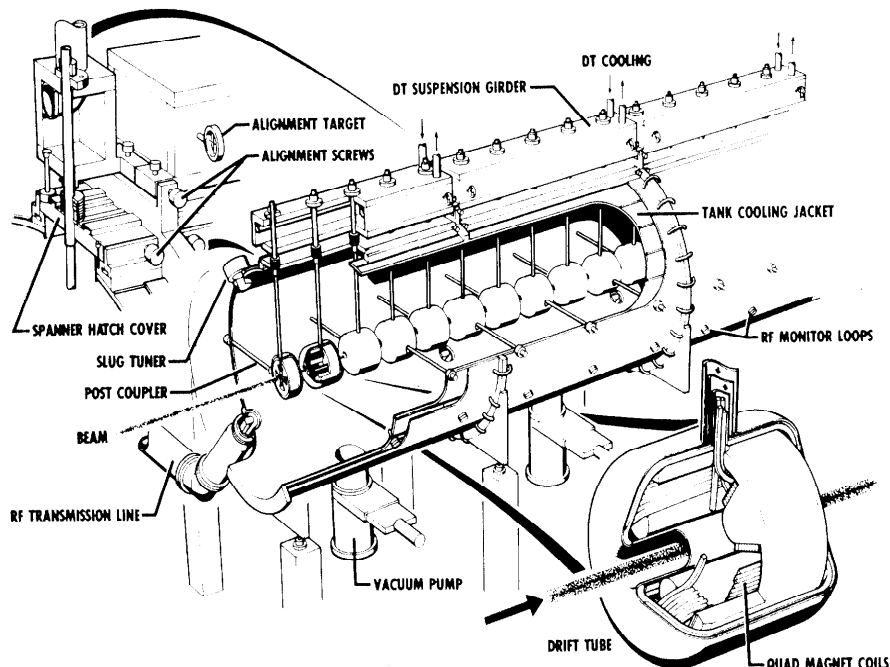

Fig. 2. FMIT girder-strongback drift-tube suspension.

of the stiffening rings, which should be very small. If this misalignment does become excessive, external adjustments of the kinematic mounts by which the girders are supported at each end can correct the problem. A great advantage of the girder-spanner approach is that only the girder-to-girder alignment is affected by small displacements of the tanks and not the drift-tube to drift-tube alignment within a girder. And, most importantly, a man need not enter the tanks for either maintenance or alignment work.

The alignment system uses bore sights along the sides of each girder (two alignment monuments per girder) relative to alignment scope mounts connected to the linac vault wall. Overlapping alignment surveys allow accurate girder-to-girder alignment (+0.25 mm) and these are carried on into the injector and HEBT elements. The alignment of the drift-tube magnetic centers is also +0.25 mm referenced to the alignment monument axis of the girder.

The SUPERFISH code<sup>9</sup> was used to optimize the drift-tube shapes. The need for power efficiency sets a limit on  $ZT^2$  to minimize the number of rf amplifiers required. At the same time, conservative field level limits of about 10.5 MV/m at 80 MHz are imposed by Kilpatrick's criterion. Thus, an average 1.4-MV/m accelerating gradient was selected. The tapered noses on the drift tubes allow all of the above conditions to be met. Because of the FMIT continuous duty, careful cooling of the drift-tube faces is required and a temperature controlled cooling system, independent of the tank cooling, is provided for this purpose. Each drift tube carries a quadrupole lens and varies in weight up to about 500 kg. Each drift-tube stem is attached to the girder at two points for stiffness and versatility of alignment. Alignment of the quad magnetic centers is done by transporting the girder to an alignment tooling dock where the girder is suspended on typical kinematic mounts.

The tank cooling jacket is a 10-mm steel shell button welded to spacers for longitudinal counterflow flood cooling. Counterflow cooling makes the average temperature at any point along the tank constant despite the 2.8°C temperature rise allowed along a given channel to carry away approximately 5.5 kW/m<sup>2</sup> caused by 1.5-MW rf power dissipated in copper losses. The average water temperature in the tanks is held constant at nominally 29°C with ±0.3°C tolerance.

In addition to the girder assemblies a number of other tank penetrations are shown in Fig. 2. These include the 15 distributed rf coupling loops; 4 motor-driven slug tuners 2 per tank; a number of rf H-probes for closing the rf phase and amplitude servo loops; and 72 post couplers, 1 per drift tube. The post couplers are necessary to stabilize the rf fields. The vacuum ports are of the appropriate geometry to attenuate the rf fields so that elaborate water-cooled grilles are not required. An externally hung conventional vacuum system again was dictated by the need to free the tank interior from all possible man-maintained equipment.

## Proof-of-Principle Prototype

All the FMIT design, up to 5 MeV, will be checked at LASL with a full duty prototype producing a 100-mA H<sup>2</sup> beam. This system will include a prototypical 100 keV injector, an 80-MHz RFQ to raise beam energy to 2 MeV, and an 80-MHz drift-tube linac from 2-5 MeV. The multiple drive rf system and its phase and amplitude control servos, and the energy dispersion cavity will also be prototyped. The prototype drift-tube linac will use a suspension girder assembly identical to the first FMIT girder so alignment and maintenance techniques can be checked. The 500-KW beam will be analyzed in a short non-prototypical transport line and will be delivered to a radiation-cooled rotating graphite beam stop. The 15-μA deuteron component of the beam that is normally present in 100 mA H<sup>2</sup> will cause some small activation buildup and occasional short tests will be conducted with a full current deuteron beam.

## Summary

The design of the FMIT accelerating structures incorporates techniques of alignment and maintenance that minimize the need for exposure of personnel to potential activation hazards. This same philosophy also is being utilized in the HEBT. Heavy reliance on beam dynamics codes and rf design codes is necessary to assure a power efficient structure with low beam spill. Proof-of-principle testing of the first 5 MeV of FMIT will be conducted on a full current, continuous duty prototype to be constructed at LASL.

## Reference

1. R. Jameson, "High Intensity Deuteron Linear Accelerator (FMIT)," (presented at the 1979 Particle Accelerator Conference (paper B-1), San Francisco, CA, March 12-14, 1979).
2. P. Grand, et al., "An Intense Neutron Source Based upon the Deuteron Stripping Reaction," Nuclear Instruments and Methods 145 (1977) 49-76.
3. R. Jameson, "Workshop Notes--HEDL Frequency Choice Workshop, April 12-13, 1978," Los Alamos Scientific Laboratory internal document (April 1978).
4. Kapchinskii, et al., "Linear Ion Accelerator with Spatially Homogeneous Strong Focusing," Nuclear Experimental Techniques, UDC 621.384.64.
5. J. Potter, et al., "RF Quadrupole Accelerating Structure Research at Los Alamos," presented at the 1979 Particle Accelerator Conference (paper D-12), San Francisco, CA, March 12-14, 1979.
6. K. Melson, et al., "High Energy Beam Transport in the Hanford FMIT Linear Accelerator," presented at the 1979 Particle Accelerator Conference (paper M-1), San Francisco, CA, March 12-14, 1979.
7. R. Stokes, et al., "RF Quadrupole Beam Dynamics," presented at the 1979 Particle Accelerator Conference (paper F-4), San Francisco, CA, March 12-14, 1979.
8. B. Ioffe, et al., "The Scheme of a 14-MeV Intense Neutron Generator," Proposal by ITEP, ITEF, ITEF-118, 1977.
9. G. Boicourt, et al., "Choice of Geometry for the Alvarez Section of the FMIT Deuteron Linac," presented at the 1979 Particle Accelerator Conference (paper F-4), San Francisco, CA, March 12-14, 1979.