

OPERATION OF A HIGH-CURRENT XENON SOURCE*

Warren Chupp, Dave Clark, Robert Richter, John Staples, and Emery Zajec**

Introduction

The development of heavy ion accelerator driver systems for inertial confinement fusion will also require the development of high current heavy ion sources. High current plasma arc sources have already been developed at LBL in connection with the neutral beam program.¹ This paper reports the results of adapting the Ehlers type source to produce singly charged Xenon ions and subsequently accelerate them to 500 kilovolts.

Summary

A multi-aperture Ehlers-type source has been constructed and operated to produce a 60 mA Xe^{1+} beam. The multi-aperture source utilizes a 13 hole aperture in a circular pattern producing a beam 25 mm in diameter. An "accel-decel" extraction system was used, producing a 22.5 keV beam whose normalized emittance at 29 mA was 0.027π cm-mrad. The neutralized beam was transported one meter through two magnetic quadrupole triplets to the entrance of a 20 cm accelerating gap consisting of five intermediate electrodes with a total voltage drop of 500 kV. The vacuum in the extraction region was held to 10^{-5} Torr by using a puff valve and two 1500 l/sec turbo pumps. Multi-wire profile monitors just ahead of the column entrance measured the beam size, which was in good agreement with single-particle transport calculations.

Ion Source Geometry

A schematic of the multi-aperture xenon source is shown in Figure 1. The electron current is supplied by a circular array of 8 .02" dia. tungsten filaments connected in parallel. The large hemispherical anode is shaped to reduce the arc potential, favoring Xe^{1+} production. The extraction lens is a 13 hole accel-decel system with typical operation voltages of 25 and 3 kV. Figure 2 illustrates the three hexagonal multi-aperture electrodes, the support insulators, and the source body in the order of assembly.

The filament and anode structure of the source was developed from an early model used in the LBL neutral beam project under W. Kunkel. This model was kindly lent to us by K. Berkner.

Low Voltage Test Stand Facility

The low voltage test stand consists of four principle components: the xenon source including its accel-decel lens, the pumping system, a 4 inch quadrupole triplet, and a 50 degree analyzing magnet. Two Sargent-Welch turbomolecular pumps provide a pumping speed of 3000 l/sec at the ion source, while a diffusion pump and an additional turbomolecular pump provide 1650 l/sec pumping in the transport system.

*This work was supported by the Inertial Fusion Department of the U.S. Department of Energy under contract No. W-7405-ENG-48

**Lawrence Berkeley Laboratory
1 Cyclotron Road
Berkeley, Calif. 94720

Diagnostic equipment includes several Faraday cups, a 32-wire X-Y beam profile monitor, a slotted plate emittance measuring device, and two sets of X-Y jaws to determine the beam size. Extraction and decel lens potentials are supplied by two unregulated supplies capable of delivering 80 kV at 10 mA dc with additional capacity to compensate for beam loading effects. The arc supply can deliver 300 volts at 50 amperes with a pulse length of 500 μ sec, and the paralleled source filaments are powered by a 10 volt 150 ampere dc supply. Pulsed gas is supplied to the source by a voltage-controlled piezo-electric valve.

The plasma density in the ion source was measured by inserting a Langmuir probe through the arc chamber perpendicular to the beam axis. The uniformity is within $\pm 1.5\%$ over the area of the 13 hole extraction area. Typical values of plasma density vary between 35 to 100 mA/cm² for a filament current of 136 amperes.

Most of the development work with the low voltage test stand was aimed at obtaining maximum beam current at the Faraday cup 1.3 meters from the source. A collimator was usually used in front of the cup, set to simulate the 1" dia. entrance aperture of the accelerating column of the high-voltage test stand. The geometric (unnormalized) acceptance area of this system is 90π cm-mrad horizontally and 34π cm-mrad vertically when the collimator full widths are 1 inch square. With this collimation 35 mA of Xe^{1+} was measured in the cup.

It was found important to use a transverse magnetic bias of a few hundred gauss on the cup to eliminate the effects of stray electrons from various sources. With only electrostatic bias of the collector or an electrostatic suppression ring, the current collected varied continuously with positive or negative bias voltage, indicating that a plasma existed in the beam pipe. The current measured in a beam transformer just after the source was up to 60 mA, but this includes electron current moving in the plasma column toward the source and was not used in the data analysis.

Calculations of beam optics with space charge included showed that even 1 mA of uncompensated space charge would cause a factor of 2 loss in transmission, so the 35 mA beam in the cup was at least 97% neutralized. The fact that the experimental settings of the quadrupoles were within 15-20% of those calculated without space charge indicated that the space charge is well compensated.

The neutralization is due to secondary electrons from beam hitting the pipe and collimators, and from beam ionization of the residual gas (mostly xenon near the source). This latter process occurs in roughly 300 μ sec, for 20 keV ions in a gas pressure of 10^{-5} Torr and an ionization cross section of $3 \cdot 10^{-16}$ cm². The observed rise time of the beam pulse at the cup is 30 μ sec, indicating a large contribution of the fast wall electrons to neutralization. The transport loss to the charge exchange $Xe^{1+} + Xe^0 \rightarrow Xe^0 + Xe^{1+}$ is estimated to be about 9%.

Analysis of Low Voltage Test Stand

The emittance of the Xe^{1+} beam from the source was inferred from a two-slit interception technique. With a Faraday cup measuring the total beam current, a two-jaw aperture is closed down upon the beam until a reduction in intensity is detected. Then a second aperture between the first aperture and the Faraday cup is closed down until it just intercepts the beam. To calculate the emittance in the active plane of the jaws, either the beam size at a third point or the position of the beam waist must also be known. The position of the waist from previous beam dynamics calculations is known to be within ± 10 cm of the first aperture. A calculation of the emittance with the waist anywhere in this region results in only a 10% uncertainty in the calculated value of the emittance, which is considered adequate accuracy.

Measurements of the Xe^{1+} beam size with two slits .81 m apart gave a beam radius of 1.08 and 3.81 cm. The unnormalized emittance area calculated from these data with the waist within ± 10 cm of the first slit is $\pi\epsilon_N = 45 \pm 10\%$ cm-mrad. For a total acceleration voltage of 22.5 kV, this corresponds to a normalized emittance area $\epsilon_N = .027 \pi \pm 10\%$ cm-mrad. Approximately 5% of the beam was intercepted on the slits, so this emittance area corresponds to the 95% contour. The current within this contour is 29 mA.

High Voltage Test Stand Facility

After initial tests on the xenon source were completed in the low voltage facility, the xenon source was installed in a 500 kV test terminal. A schematic drawing of the terminal, transport and diagnostic systems is shown in Figure 3. Primary power for the dc filament supply, the four pulsed quadrupole supplies, the two turbomolecular pump supplies and other equipment is supplied by a 15 kW 400 Hz and a 5 kW 60 Hz alternator.

A 32 wire X-Y beam profile monitor is located at the entrance of the accelerating column to aid in the tuning of the pulsed quadrupoles. The beam current is monitored by a Faraday cup immediately following the source in the pumping manifold and by a 1-1/2" dia. Faraday cup near the exit of the accelerating column which is movable along the inside of the beam pipe from the column exit to some distance downstream. This cup was removed when the 30° analysis system shown in Figure 3 was used and replaced by cups near the entrance and exit of the analyzing magnet. Two quadrupole singlets upstream of the 30° analyzing magnet focus the beam.

Analysis of 500 keV Xe^{1+} Test Data

The emittance of the 500 keV Xe^{1+} beam was inferred from measurements of the transmission of the beam through a 3/4" diameter aperture followed downstream by a 1-1/2" diameter aperture, each at several longitudinal positions in the 500 keV beam. This technique is somewhat sensitive to the current density profile, which is not known in detail. Using fitting procedure, assuming the current density profile to be either uniform or parabolic, results in a 13% uncertainty in the calculated emittance, considered to be of satisfactory accuracy.

For a typical run, with the 3/4" aperture 21.0 cm from the last electrode in the 500 kV accelerating column, the current through the 1-1/2" aperture is measured from 14 to 35 mA with the larger aperture 61 to 15.2 cm downstream of the smaller aperture. The 3/4" aperture is positioned so that it is just start-

ing to intercept the beam. For a uniform (parabolic) distribution, the waist is calculated to be 15 (11) cm upstream of the small aperture and the unnormalized emittance area of the transmitted beam to be 30π (40π) cm-mrad, corresponding to a normalized emittance area of $.084\pi$ ($.11\pi$) cm-mrad at 500 keV. The transmitted beam current was 35 mA in this run. Currents of up to 60 mA have been produced, but the emittance at these higher currents has not been measured.

The 500 keV 35 mA beam was also magnetically analyzed by a magnetic spectrometer which deflected the beam through 30°. The Xe^{1+} charge state was found to be 90% of the total when operating at an arc voltage of 20 V. As is to be expected, higher arc voltages lower the Xe^{1+} percentage through the production of higher charge states. A complete charge state analysis has not been done at this time although it would be of interest to explore the production of higher charge states under different operating conditions.

References

1. W. R. Baker, et.al, Proceedings of the Symposium on Ion Sources and Formation of Ion Beams, BNL Conf. Report, 1971.

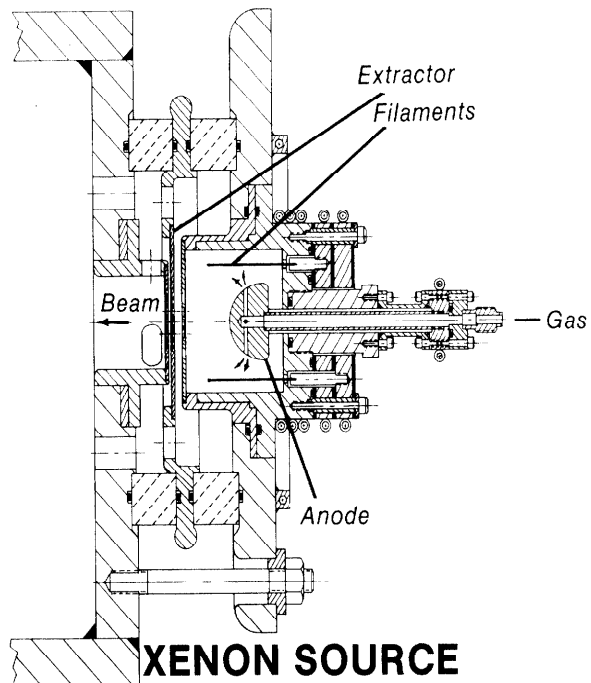

XBL 793-8705

FIGURE 1

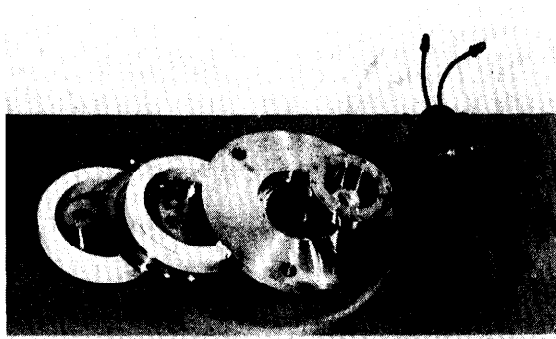
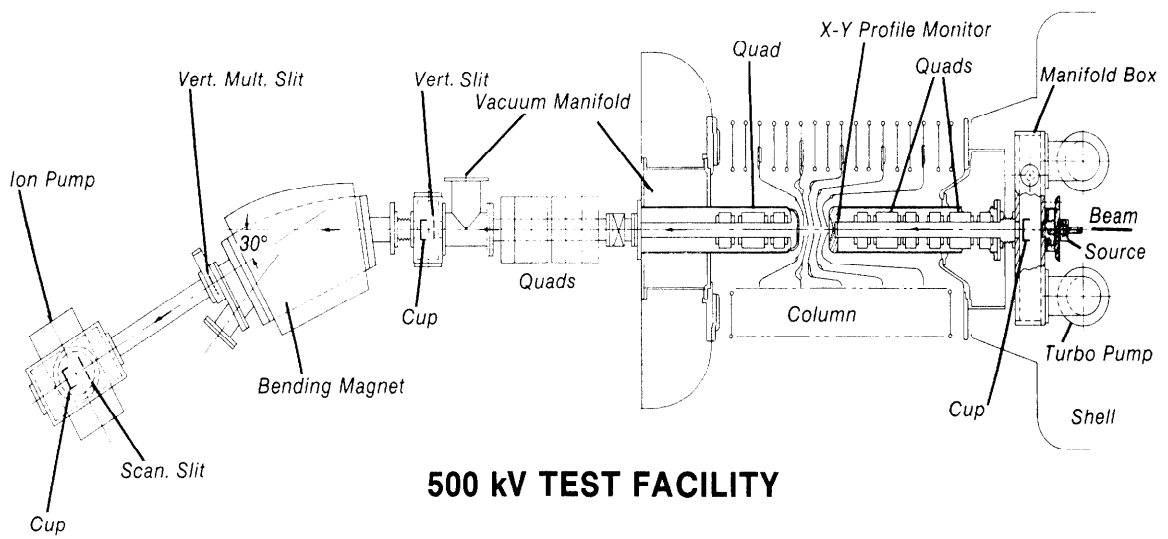

FIGURE 2 - XENON SOURCE DISASSEMBLED



XBL 793-8706

FIGURE 3