

THE FMIT ACCELERATOR VACUUM SYSTEM*

M. D. Machalek, E. A. Meyer, and L. S. Price†
 Los Alamos Scientific Laboratory, Los Alamos, NM 87545

Abstract

The Fusion Materials Irradiation Test (FMIT) Facility accelerator is being designed to continuously accelerate 100-mA deuterons to 35 MeV. High vacuum pumping of the accelerator structure and beam lines will be done by ion pumps and titanium sublimation pumps. The design of the roughing system includes a Roots blower/mechanical pump package. For economy the size of the system has been designed to operate at 10^{-6} torr, where beam particle scattering on residual gases is negligible. For minimum maintenance in this "neutron factory," the FMIT vacuum system is designed from the point of view of simplicity and reliability.

Introduction

The FMIT Facility is a "neutron factory" being built to evaluate candidate materials for the first walls of fusion reactors. The basic components of the facility consist of a high-current (100 mA at 35 MeV) deuteron accelerator, lithium targets to strip the protons from the deuterons and test cells in which material samples will be bombarded by the resultant 14-15 MeV neutrons. The Hanford Engineering Development Laboratory (HEDL) will build and operate the FMIT Facility in Richland, Washington. The Los Alamos Scientific Laboratory (LASL) will design and develop the FMIT accelerator, which will be installed at HEDL.

Because the FMIT is being designed to operate continuously for ten to twenty years, criteria for the vacuum system design emphasize simplicity and reliability. Except in the injector there are no moving mechanical components in the accelerator vacuum system during beam-on and there are no baffles, traps, or liquid nitrogen in the system. Gate valves and separate roughing ports allow individual pumps to be serviced or replaced without seriously affecting accelerator tank vacuum.

The FMIT accelerator vacuum system can be broken down into three subsystems: the injector vacuum, the accelerating section vacuum, and the High-Energy Beam Transport (HEBT) vacuum.

Injector Vacuum Subsystem

The injector vacuum system shown in Fig. 1 consists of two parts. The 10 000-ℓ/s oil diffusion pump, backed by a blower and mechanical pump, removes un-ionized deuterium from the ion source. A 1200-ℓ/s hydrogen ion pump handles the residual deuterium flowing down the beam line plus the gas load from beam impingement on the beam defining variable iris.

The high pumping speed of the diffusion pump keeps the pressure low between the extractor electrodes to minimize ionization of the residual gas by the beam. Electrons from ionization in the gap produce x-rays (Bremsstrahlung) of up to 100-keV energy that can cause insulator charging and subsequent high voltage breakdown. A 47-ℓ/s two-stage canned motor blower and

a 15-ℓ/s mechanical pump back the diffusion pump and are also used to rough pump the main system and the ion pump. The canned motor design minimizes oil backstreaming to the diffusion pump; the high pumping speed and low ultimate pressure of the two-stage pump reduce system roughing time and ion pump starting time, which minimizes oil contamination during roughing. A zeolite trapped 0.4-ℓ/s mechanical pump backs the oil diffusion pump when the blower is used for roughing.

Considerable attention has been given to minimizing oil contamination because it might coat the insulators and cause high voltage breakdown in the extractor. The following precautions have been taken at the diffusion pump:

1. Chilled water to the cold cap and cooling lines.
2. Freon-refrigerated chevron trap immediately above the pump.
3. Use of low vapor pressure polyphenyl ether pump fluid.
4. Pressure actuated valve on the exhaust line to prevent sudden air leak from blowing diffusion pump oil into the system.

Experience to date has been very satisfactory with this system on the pre-prototype model. The system has remained very clean and there is no trace of oil on the ion gauge walls. There are no high voltage breakdown problems in the 100-kV extractor.

The main gas load in the 400-ℓ system is the 0.1-torr ℓ/s deuterium input that results in a pressure of 2×10^{-5} torr at the bending magnet chamber. A 1200-ℓ/s ion pump designed for hydrogen to obtain maximum pump life reduces beam line pressure to 2×10^{-6} torr. Pumping cell modifications reduce plate warping and spalling that result from pumping hydrogen isotopes. Argon sputtering procedures will be used in the pump to remove the surface barrier to diffusion of neutral deuterium molecules into the titanium plates and increase the pumping speed to nearly 3000 ℓ/s.

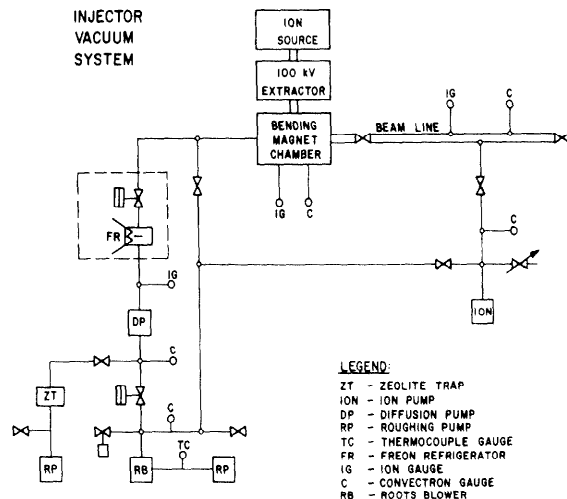

Fig. 1. The FMIT accelerator injector vacuum system.

*Work supported by the U. S. Department of Energy.
 †Hanford Engineering Development Laboratory (HEDL), Westinghouse-Hanford Company, Richland, WA, HEDL employee working at the Los Alamos Scientific Laboratory.

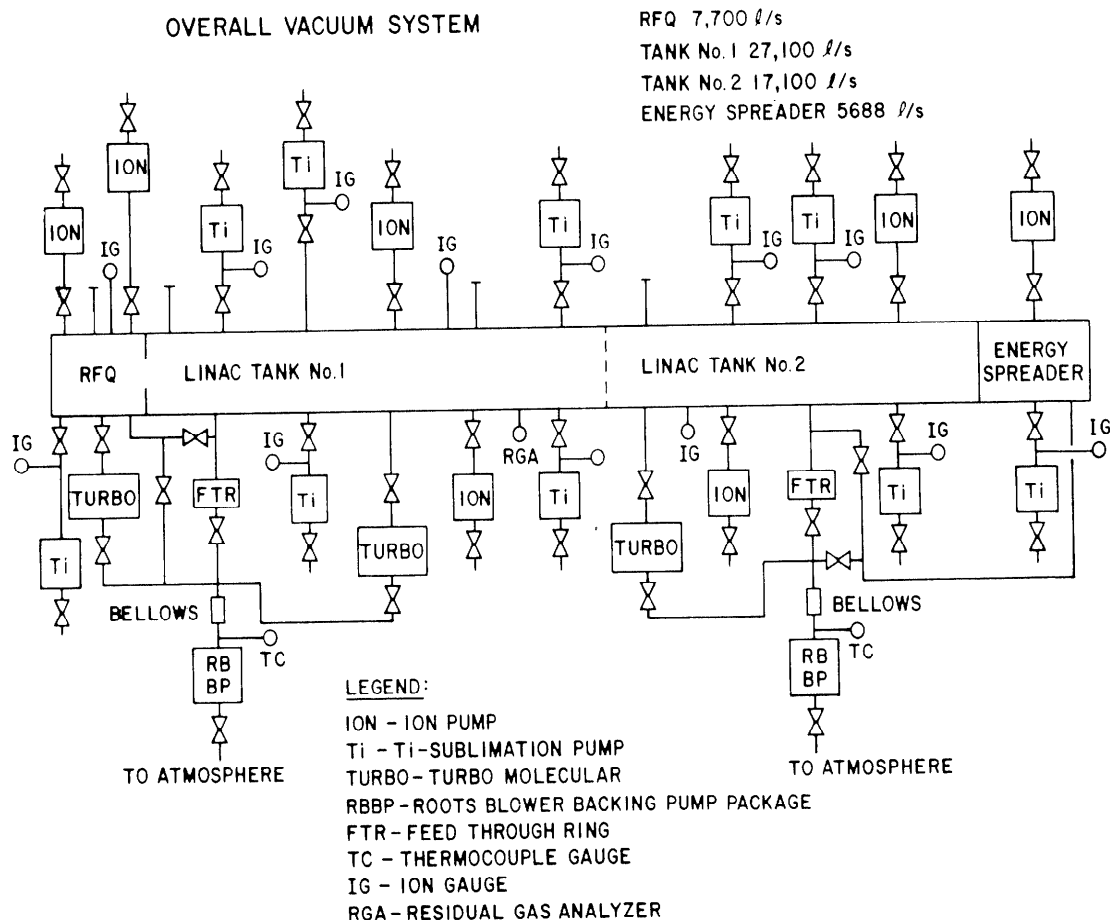

Fig. 2. The overall vacuum system for the FMIT accelerator.

Accelerator Vacuum SubSystem

The accelerating section of the facility accelerator consists of two types of structures: a new structure called the Radio-Frequency Quadrupole (RFQ) accelerates beam particles from 0.1 MeV up to 2 MeV and a conventional Alvarez drift-tube linear accelerator (Linac) accelerates the beam from 2 MeV to 35 MeV. In addition, each system can be characterized by three pressure regimes: (1) roughing (atmospheric pressure to $\leq 10^{-3}$ torr), (2) intermediate roughing ($\leq 10^{-3}$ torr - 10^{-6} torr), and (3) operating ($\leq 10^{-6}$ torr).

A paper on the RFQ design details¹ and one on the FMIT Linac design details² will be presented at this conference.

The RFQ is basically a cylinder but its internal structure is still being designed. At present we estimate the volume to be 19 m^3 and the surface area exposed to vacuum to be 77 m^2 .

The Linac is also a cylindrical structure, approximately 2.5 m in diameter and 33-m long. Suspended inside the cylinder will be 72 drift tubes that are thick-walled cylinders 37-40 cm in diameter, having a bore of 5-10 cm and progressively increasing in length from 15 cm to 54 cm at the output of the Linac. Approximately midway along the tank there is an inter-tank spacer that divides the tank into two separate rf cavities/vacuum tanks. The Linac volume is $\sim 150 \text{ m}^3$ and the surface area is $\sim 440 \text{ m}^2$. Virtually all accelerator vacuum surfaces are copper.

Attached to the Linac output will be a very short beam energy spreader cavity, whose vacuum conditions need to be equivalent to those of the Linac. Because of required mechanical separation, the energy spreader is essentially "tank 3" of the Linac. Although the energy spreader is still to be designed, its volume is expected to be of the order of one cubic meter and its surface area, a few square meters.

The roughing system for the RFQ/Linac will consist of two Roots blowers/mechanical backing pump packages. The Roots blowers, besides reducing pump-down time, protect the accelerator system from oil backstreaming from the mechanical pumps.

The intermediate roughing system will incorporate turbomolecular pumps in series with the Roots blower packages. Turbopumps will greatly aid pump-down in the 10^{-3} torr to 10^{-6} torr range and additionally can be used during beam-off conditions to assist the high-vacuum ion pump and titanium sublimation pumps.

The operating vacuum system will use a combination of ion pumps and titanium sublimation pumps. This combination was chosen because (a) no moving mechanical parts are used, (b) radioactive gases, should they be produced during beam-on conditions, are trapped, (c) both inert and active gases are pumped, (d) maintenance is relatively simple, and (e) costs are reduced from an equivalent speed all-ion pump system.

Loss of accelerator beam particles because of scattering off background gas is negligible at

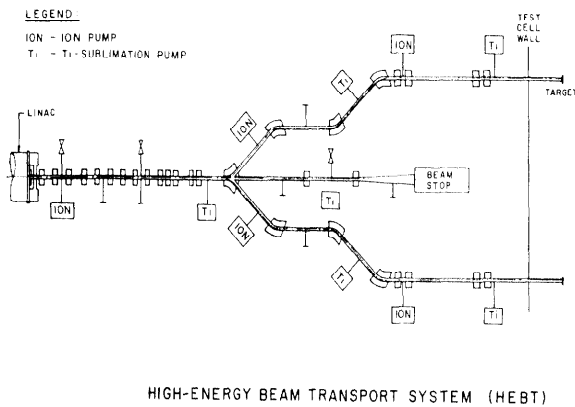

Fig. 3. The vacuum system for the High-Energy Beam Transport (HEBT) system for the FMIT Facility.

pressures in the low 10^{-6} torr range. Therefore, the vacuum system is designed to operate only in the 1×10^{-6} torr to high 10^{-7} torr range; attempts to maintain lower pressures only increase system costs and probably do not improve accelerator performance. Net pumping speeds for the four sections (RFQ, Linac tank 1, Linac tank 2, and energy spreader tank) of the accelerating structure are calculated to be 7700 ℓ/s , 27 100 ℓ/s , 17 100 ℓ/s and 5688 ℓ/s , respectively.

Ion pumps and titanium pumps will have 30.5-cm (12-in.) throats and will be isolated by 30.5-cm

(12-in.) gate valves. The pumps will be attached to the Linac tanks by 46-cm ID, 46-cm-long tubes and 50%-transparency rf grilles allowing penetration through the Linac tank walls. Figure 2 shows the overall FMIT Vacuum System.

HEBT Vacuum Subsystem

The HEBT vacuum is shown schematically in Fig. 3. The individual beam lines can be isolated from one another and from the targets by pneumatically actuated valves. The ion and titanium pumps need not be isolated by valves from the small volume beam lines. Extra blanked-off pump-out ports are included for future pumps or instrumentation, should they be needed. Valved-off ports are for roughing the beam lines using a portable Roots blower system.

The gas type and gas load coming from the targets are still undetermined. However, current designs call for 500 ℓ/s ion pumps and titanium sublimation pumps with 20.3-cm (8-in.) throats. "Top hat" sections will be built into the HEBT where practical and will be close coupled to the pumps to optimize pumping speed.

References

1. J. M. Potter, R. H. Stokes, C. W. Rodenz, and F. J. Humphry, "RF Quadrupole Accelerating Structure Research at Los Alamos," presented at the 1979 Particle Accelerator Conference (Paper D-12), San Francisco, CA, March 12-14, 1979.
2. D. Liska, R. Schamaun, and C. Fuller, "Design of the Accelerating Structures for FMIT," presented at the 1979 Particle Accelerator Conference (Paper M-2), San Francisco, CA, March 12-14, 1979.