

IEEE Transactions on Nuclear Science, Vol. NS-26, No. 3, June 1979

HIGH-INTENSITY DEUTERON LINEAR ACCELERATOR (FMIT)\*

Robert A. Jameson  
Los Alamos Scientific Laboratory, AT-DO, MS 811,  
P. O. Box 1663, Los Alamos, NM 87545

Abstract

For fusion reactors to become operational, one of the many problems to be solved is to find materials able to withstand the intense bombardment of 14-MeV neutrons released by the fusion process. The development of alloys less likely to become damaged by this neutron bombardment will require years of work, making it desirable to begin studies in parallel with other aspects of fusion power generators. The Fusion Materials Irradiation Test (FMIT) Facility, to be built at the Hanford Engineering Development Laboratory (HEDL), Richland, Washington, will provide a high neutron flux and a neutron energy spectrum representative of fusion reactor conditions in volumes adequate to screen and qualify samples of candidate fusion reactor materials. FMIT's design goal is to provide an irradiation test volume of  $10 \text{ cm}^3$  at a neutron flux of  $10^{15} \text{ n/cm}^2\text{-s}$ , and  $500 \text{ cm}^3$  at a flux of  $10^{14} \text{ n/cm}^2\text{-s}$ . This will not allow testing of actual components, but samples in the most intense flux region can be subjected to accelerated life testing, accumulating in one year the total number of neutrons seen by a fusion reactor in 10-20 years of operation.<sup>1</sup>

To produce the neutrons, a 100-mA, 35-MeV deuteron beam will be directed onto a 2-cm-thick, 600-gpm curtain of liquid lithium metal, which strips the deuterons and allows the remaining neutrons to continue on to the test samples. The deuterons will be produced by the largest component of the facility, a high-intensity, continuously operating linear accelerator (Linac). The accelerator part of the FMIT facility is being designed and built by the Accelerator Technology Division of the Los Alamos Scientific Laboratory (LASL) for the HEDL. The architect-engineer for the project is the Parsons Company of Pasadena, California.

This unique joint effort, initiated in late February, 1978, is a blend of accelerator and materials science expertise, in a facility to be located near a source of economical electrical power (Fig. 1). The FMIT project cost is estimated at \$83 million with accelerator costs being ~\$35 million of that total. The schedule requires prototype R&D work and system design to be accomplished at LASL (using laboratory and office facilities provided under the joint agreement), procurement and installation at the HEDL site, and initial beam-on-target operation by late 1983. A staff of ~50 LASL and 20 HEDL personnel is presently being assembled at Los Alamos for the Linac activities. Figures 2 and 3 show the proposed layout of the accelerator and test cells. The facility is being designed for a 20-year plant life with 80% plant availability, implying a high design availability for the Linac. Output current may vary from 30-100 mA, and one additional deuteron energy between 20 and 25 MeV will be provided. "Hands-on" maintenance for accelerator components is also a design goal. These requirements demand conservative design and the most careful attention to fundamental factors that affect beam losses along the accelerator and transport lines.

Basic Design Choices

The beam losses from the FMIT Linac must not exceed in actual amount those from existing machines, in spite of an operating intensity hundreds of times more. Because sustained losses of only a few microamperes can cause component handling problems, the designer is interested in knowing where all of the beam goes, down to four to five orders of magnitude below the total current. Several presently operating proton linear accelerators have demonstrated the acceleration of pulsed currents in excess of 100 mA to energies greater than 35 MeV. These pulsed machines, however, operate at low duty factors and impediments to maintenance from radiation buildup caused by spilled particles have not been a concern. The nearest high-intensity operating experience comes from LAMPF, which has been running at 500- $\mu$ A average current with 5- to 7-mA peak current.

Extrapolation to the design of FMIT from these machines must be made with great care. Because beam spill was not a major concern, measurement methods that could look at machine performance characteristics to the necessary resolution have not been developed or used. Non-intercepting measurements of beam centroid information are made, but profile measurements on full-intensity beams are not available. Radiation detectors have indicated<sup>2</sup> that carefully tuned conventional machines may operate for short periods at the desired low spill levels, but these measurements lack the discrimination necessary to provide design information. These tests also indicate the need for extensive engineering to guarantee stable, consistent performance over long periods.

Present analytical theory gives guidance on the basic features of linac design, but cannot provide information to high precision on the non-linear behavior of intense, space-charge dominated beams. Numerical simulation codes used for this purpose have been highly developed over the past years,<sup>2</sup> but at present are quantitatively accurate to only a few per cent.

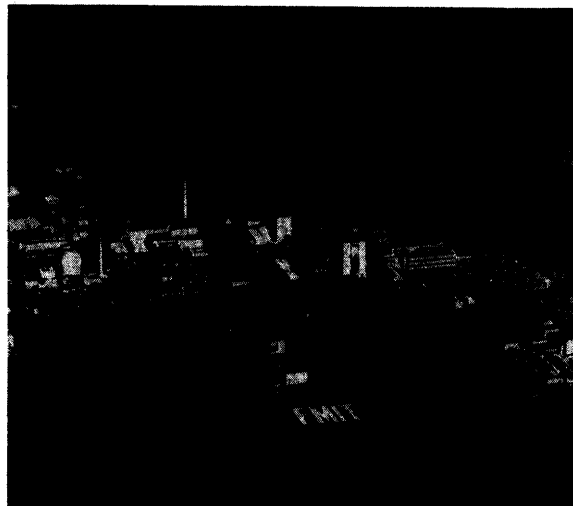

Fig. 1. Aerial view of the FMIT site on the Columbia River at the Hanford Engineering Development Laboratory, Richland, Washington.

\*Work supported by the U. S. Department of Energy.

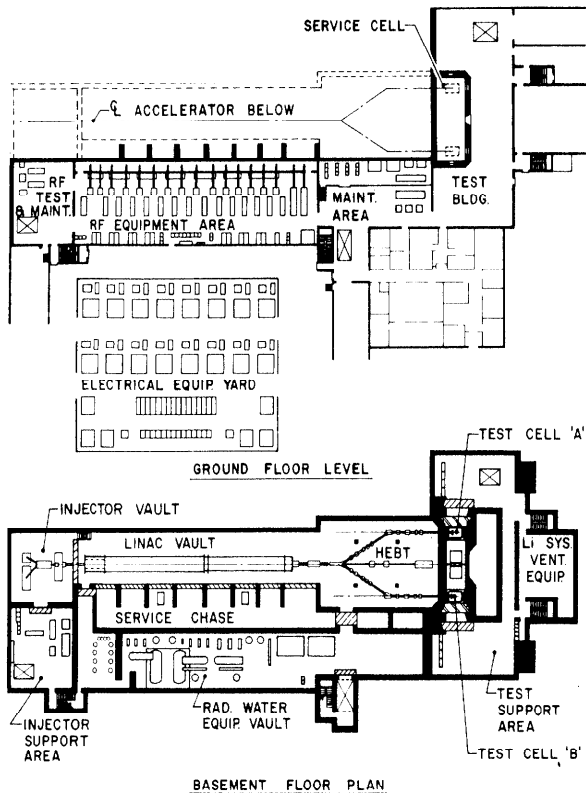

Fig. 2. FMIT Facility layout from Title I Design Study.

A number of proposals<sup>3-6</sup> for deuterium-lithium neutron sources have been written, with varying degrees of concern for beam spills. The USSR proposal, based on extensive analytical work, some hardware experience, and using a revolutionary low-energy accelerating structure discussed further below, takes an unequivocal position at one end of the spectrum; they believe that remote maintenance will be essential for a 100-mA machine.

Given this state of the art in operating experience and design techniques, from which we must extrapolate over two orders of magnitude in average current, and given the desired time schedules for the FMIT project, we have therefore decided to:

(a) Concentrate R&D effort on the low-energy part of the facility from injector to about 5 MeV, because beam formation and capture at injection will determine the spill characteristics. A complete prototype to 5 MeV will be built at LASL.

(b) Proceed immediately with design of a drift-tube linac from 2 MeV to 35 MeV, using existing tools and experience, and assigning conservative safety factors. This will allow committing about 80% of the accelerator costs and all of the building costs in parallel with the prototype work.

(c) Incorporate the capability for remote handling of accelerator components into the machine design from the very beginning, to insure feasibility and identify cost impacts early.

We next discuss the areas where R&D would be necessary and the tradeoffs involved. It is well known that from the beam dynamics point of view, the most critical part of a linear accelerator is the section that transforms the dc beam from the ion source into a bunched beam and accelerates the bunches through the first few MeV. The strong space-charge forces in the high-intensity linacs now being designed

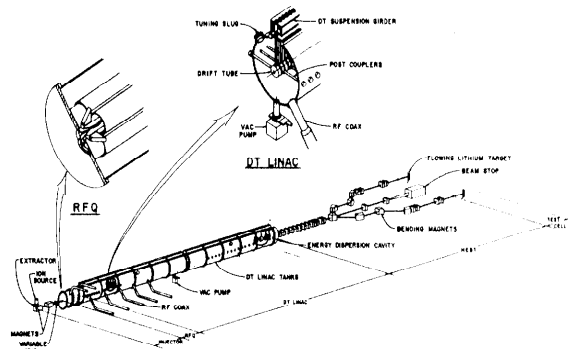

Fig. 3. Pictorial schematic of FMIT Linac components.

compound the problem significantly. There are equally important engineering constraints on this same part of the machine. A resolution of the following factors is necessary.

(a) Discussions<sup>7</sup> on the present and projected state of the art in ion sources and high voltage accelerating columns indicate that significant developmental problems could be expected for cw injector systems in excess of about 400 kV.

(b) The drift-tube Linac becomes severely constrained by the requirements for magnetic quadrupole focusing as the injection energy is lowered, especially when strong focusing is desired to minimize spill, and represents a significant design challenge at 400 keV even if the frequency were lowered to 50 MHz.

(c) Simple cavity-plus-drift bunching systems have two major shortcomings: they do not sufficiently depopulate the outer regions of longitudinal phase space, leaving particles that are likely to be lost because of machine imperfections; and they lack the ability to precisely match the longitudinal phase-space characteristics of the input bunch to those of the linac, causing undesired coupling and emittance growth. Many more complicated schemes have been suggested,<sup>8,9</sup> but all have been plagued by complexity and the tendency to improve the longitudinal phase-space properties at the expense of the transverse, with no (or negative) overall gain.<sup>10</sup>

There are also several mitigating factors. Recent work<sup>11-15</sup> leading to a better understanding of the space-charge and rf gap effects in linacs has indicated that higher operating frequencies are advantageous in controlling transverse emittance growth, and that transverse emittance growth is correlated to a lesser extent with the choice of synchronous phase and accelerating gradient but is substantially independent of injection energy. This allows some leeway in the choices of operating frequency and injection energy, although longitudinal considerations still require a fairly low frequency. The same work indicates the importance of strong transverse focusing and the great necessity for achieving six-dimensional matching throughout the entire acceleration process in an operating linac. Evaluation of rf system requirements indicates that reliable tubes are available, and that modern tank design and vacuum techniques would probably allow higher accelerating gradient than used in existing machines if desired for economic or beam dynamics reasons.<sup>16,17</sup>

Our awakening to the potential of a new low-energy accelerating structure development in the USSR<sup>6</sup> has led to the possibility of resolving these fundamental design choices in a truly satisfying way that attacks

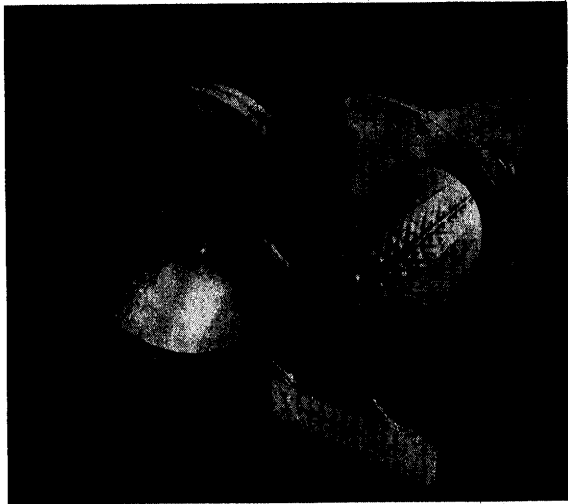

Fig. 4. Developmental version of an RFQ structure.

beam formation and capture (and therefore beam loss and beam quality) at the very heart of the matter, while at the same time greatly reducing the engineering development required for the injector and drift-tube Linac systems. This structure, employing the principle of "space-uniform-focusing," must be developed. We are now quite confident, based on extensive work during the past year,<sup>18,19</sup> that practical structures can be developed with less overall effort and time than would be required to develop a suitable cw injector at  $\geq 400$  keV, a bunching scheme, and low injection energy ( $< 750$  keV) drift-tube Linac. Further, we believe that the result will be so much better than the conventional approach that it will find wide use in other applications, including perhaps the improvement of existing machines.

The space-uniform-focusing structure, also called the radio-frequency quadrupole (RFQ) structure, (Fig. 4) basically establishes a spatially uniform, time-alternating (rf), electrostatic quadrupole field in the bore region at the ends of the four vanes. Particles of arbitrarily low energy can be transversely focused. By introducing a spatially alternating perturbation on the vanes, a longitudinal electric field component is obtained. By beginning these perturbations slowly and at the wavelength corresponding to the energy of the injected beam, the beam is adiabatically bunched. After a certain point, the vane scallops are gradually increased in amplitude and wavelength so that acceleration occurs. The important points about this process are:

- a) Essentially all of the the dc beam is captured into bunches without leaving residues (tails) in areas of longitudinal phase space where they would tend to be lost later in the Linac.
- b) The bunches are intrinsically formed with the proper longitudinal match in the space-uniform focusing structure, and can be longitudinally matched into the subsequent drift-tube Linac.
- c) The structure is ideally suited to low particle energies. In the FMIT case, this means we can inject at  $\leq 100$  keV, and then make a transition into a drift-tube linac at a few MeV, greatly easing the injector and drift-tube engineering problems.
- d) Transverse focusing strengths and matching conditions that give satisfactory transverse emittance behavior appear achievable for the FMIT parameters.

The development problems are being systematically attacked. They include tuning techniques, how to supply rf drive, tolerance requirements, fabrication

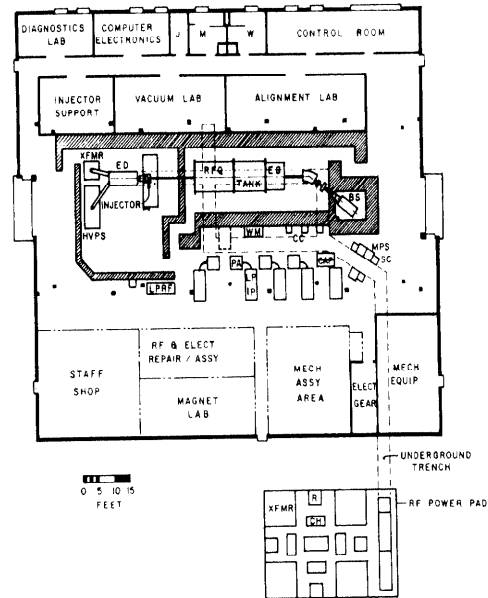

Fig. 5. FMIT prototype layout.

methods, and many other details. The first beam tests using the RFQ structure will be conducted later in 1979 at 440 MHz on an existing test stand.

#### FMIT Linac Design Status

From these basic considerations, the conceptual designs of the FMIT Linac and its accompanying prototype have proceeded rapidly; Title I work is essentially complete. The frequency of the 80-MHz has been chosen for both the RFQ and drift-tube parts of the machine. The LASL prototype layout is shown in Fig. 5; it will be completely prototypical in as many details as possible, and will serve for the development of computer control, operations, and maintenance procedures as well as component development. Occupancy of the new Prototype Building is scheduled for August 1979; beam acceleration to 5 MeV is projected for late 1980.

Injector development is being done using the test facilities from the earlier LASL Intense Neutron Source project.<sup>20,21</sup> An Osher-type reflex-arc source and single aperture extraction system (Fig. 6), designed with the aid of the SNOW transport code,<sup>22</sup> is operational and producing 100 mA of hydrogen ions at 100 keV. Emittance measurements are planned using a double scanning technique, with a goal of  $\leq 0.1\pi$  cm-mrad normalized. A parallel development of a cusp-field source is also in progress. As a backup, in the event a more conventional drift-tube linac is required, a two-stage, 400-kV injector is being designed. The 90° bend, energy analysis approach dumps unwanted ion species at lower energy, and reduces the column gas load and subsequent x-ray production.

Circular symmetry is maintained to the entrance of the RFQ section, in which the quadrupole focusing is tapered on over the first few centimeters. The beam dynamics in this device, including space charge, are being incorporated into the simulation code PARMILA and some preliminary results have been obtained.<sup>19</sup> Capture efficiencies of  $> 97\%$  appear achievable. It is interesting to note that with space-uniform focusing any particles not accelerated are transported to the entrance of the first drift-tube tank, where they are rapidly lost. Other important characteristics of the

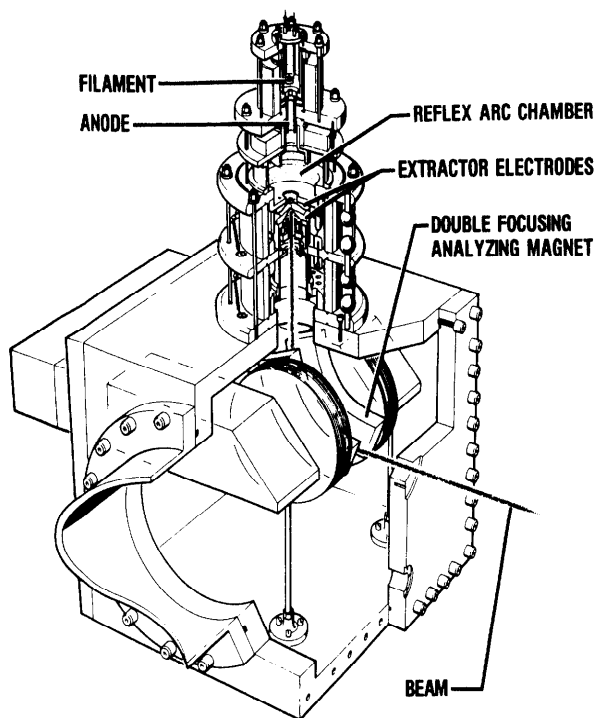

Fig. 6. Cutaway view of the ion source and extraction system.

structure are the major influence of the bore size on other parameters and the very large transverse acceptance available. Further work will include code development using time as the independent variable to treat the bunching region space-charge effects more accurately. The mechanical tolerance requirements are also being studied.

The 80-Hz operating frequency keeps the component size as small as possible while retaining conservative safety factors in the machine acceptance and current-carrying capability. A single operating frequency minimizes the rf system development effort and simplifies maintenance.

The drift-tube structure engineering design and fabrication techniques are discussed separately.<sup>23,24</sup> As shown in Fig. 7, the copper-clad steel tanks will be stiffened by heavy rings. The drift tubes, each containing an electromagnetic quadrupole, will be mounted in clusters on support girders approximately three meters long. The girder assemblies will be lowered into slots in the top of the tanks. The vacuum and rf seals to the tank structure will transfer no stress to the drift-tube support girders. This arrangement will allow the fabrication of complete drift-tube/girder assemblies, alignment in a tooling dock and transfer of internal alignment to external references, girder-to-girder alignment and/or readjustment of individual drift tubes under actual operating temperature conditions, independence of the girder system from thermal stresses in the tanks, and provisions for removal of girder sections by remote handling. A constant-field-strength, constant-length quadrupole system is being considered that maintains a strong focusing law and considerably reduces the hardware complexity of this system. The water-cooling systems will incorporate auxiliary heating to allow operation over the expected range of transient, tuning, operating and maintenance conditions, and closed-loop control to keep the system at resonance.

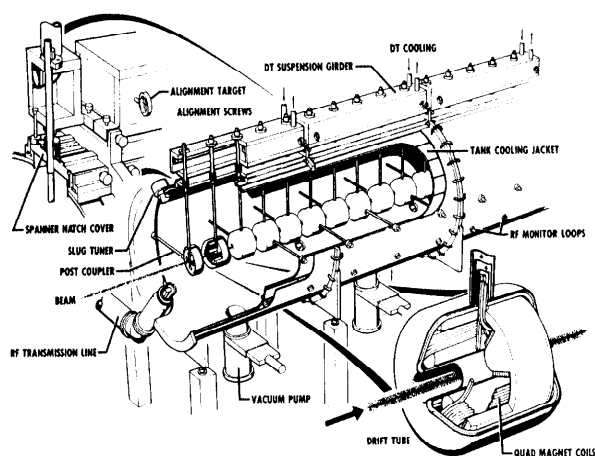

Fig. 7. Conceptual design of the drift-tube Linac tank and drift-tube support system.

The vacuum system<sup>25</sup> will use Roots blowers with mechanical backing pumps for roughing to  $10^{-3}$  torr (Fig. 8). Turbomolecular pumps in series with the roughing pumps will bring the system to  $10^{-6}$  torr, where a combination of ion and titanium sublimation pumps will take over for operation.

The rf system<sup>26</sup> unit power package size has been set at 0.5-MW cw based on completed tests of the EIMAC 8973 tetrode with a LASL cavity system. The tube was operated for 6 hours at  $\geq 450$  kW, with all parameters at  $\leq 65\%$  of maximum ratings and plate efficiency of  $\sim 65\%$ . Smooth grid modulation characteristics were also demonstrated. The FMIT will require 15 systems, including one extra amplifier per tank to allow continued operation with any one amplifier per tank out of commission. The system schematic is shown in Fig. 9; the field control system will maintain the proper rf phase and amplitude in each tank under all combinations of operating conditions. Switching to a voltage-controlled-oscillator frequency source aids in the recovery from off-resonance situations.

The design of the High-Energy Beam Transport (HEBT)<sup>27</sup> system, Fig. 10, is based on a periodic focusing and bending system that preserves the acceptance of the latter part of the drift-tube Linac up to the last quadrupole in each leg before the target. This minimizes beam loss until the last quad, where

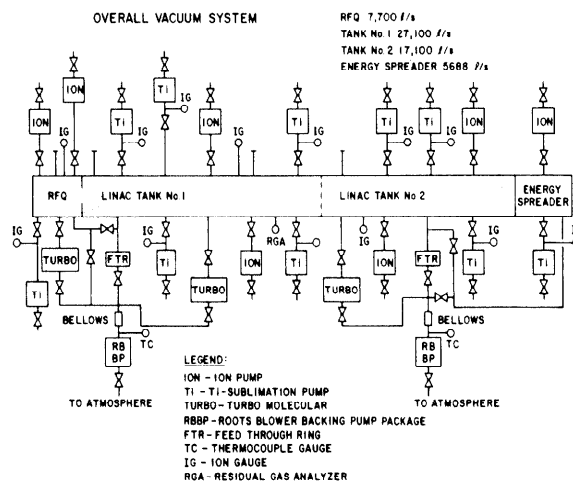

Fig. 8. Linac vacuum system.

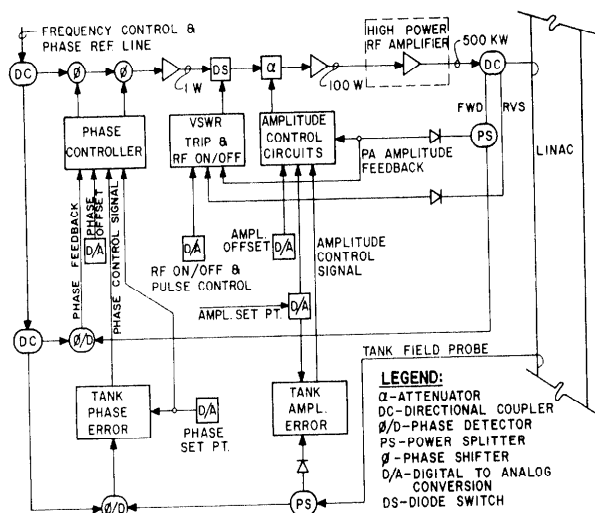

Fig. 9. RF system schematic.

some loss will be accepted on scrapers to keep the quad size within bounds. The beam is large at this point, where it is focused sharply to achieve the desired  $1 \times 3$  cm spot on the lithium target (one sigma value of Gaussian distribution). A required +500-keV beam energy spread will be provided at a time-averaged rate, high compared to the target thermal response times, by an asynchronous energy-spreader cavity operating at  $\sim 79$  MHz. This approach minimizes the space and voltage requirements for the energy-spreading system, and allows the use of rf equipment identical to that in the main system.

Control of the entire FMIT complex will be done by a computer system based upon two central computers: a primary computer for control and an auxiliary computer for data processing (Fig. 11). Local subsystems will interface information directly between the central computers and the facility or will use local micro-computers to help process data. Provisions for the use of the control system under the various maintenance scenarios are being considered.

Diagnostics and instrumentation are a challenging problem on the FMIT Linac. Conventional non-interfering current monitors, beam-spill detectors, beam centroid position monitors, and phase pickup loops will be provided. It is expected that the phase pickup loops can be developed to provide reasonably accurate phase profile information. Transverse profile or emittance information, however, cannot be obtained by conventional methods that interfere with the beam. Systems for obtaining beam profile information from beam-generated light are being studied. With profile information, emittance information can be reconstructed.<sup>28</sup>

#### Summary

The development and design of the FMIT accelerator-based neutron factory for materials research is proceeding rapidly, under a project management plan intended to optimize the commitment of project funds on the desired schedule, but with the requisite attention to R&D and prototype activities in the areas that are crucial to the long-term viability, reliability, and maintenance of the facility. The LASL-based FMIT Linac Group, under the direction of E. L. Kemp, is a completely integrated LASL/HEDL group that was formed in April 1978 and has grown during the last year into a smoothly functioning and highly motivated, effective

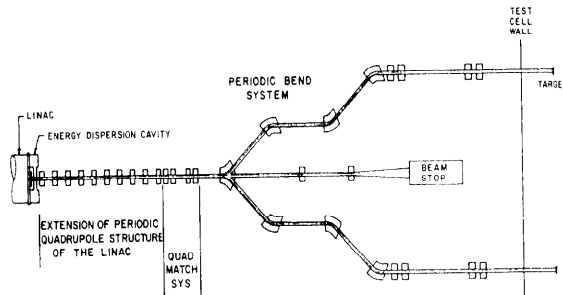

Fig. 10. High-Energy Beam Transport system.

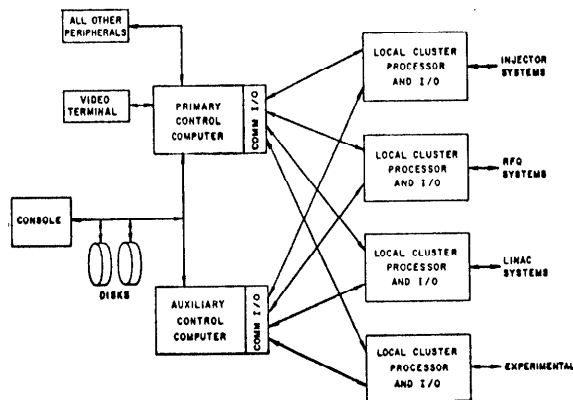

Fig. 11. Facility control system schematic.

team. They are ably augmented by the structure design and beam dynamics expertise of the Linac Technology Group led by D. A. Swenson. Synergism with other projects of the LASL Accelerator Technology Division under E. A. Knapp continually aids progress toward the FMIT goals, and the FMIT project itself has important connotations for the future development of high-intensity accelerator applications, for example, in nuclear fuel production or heavy-ion fusion. The contributions and dedication of all these people, and the support of the FMIT project offices at HEDL and the DOE, are gratefully acknowledged.

#### References

1. "Functions and Requirements, Fusion Materials Irradiation Test Facility (FMIT)," draft prepared by the Westinghouse Hanford Co. for the DOE, ROO, Richland, Washington, (Sept. 1978.)
2. R. A. Jameson, editor, "Space Charge in Linear Accelerators Workshop," Los Alamos Scientific Laboratory report LA-7265-C, (Los Alamos, NM, October 31-November 2, 1977).
3. "Proposal for an Accelerator-based Neutron Generator," Brookhaven National Laboratory report BNL 20159 (July 1975) and Addendum, BNL 20840 (Jan. 1976).
4. J. Staples, et al., "A Deuteron Linac for a High-Intensity Neutron Source," Proc. 1976 Proton Linear Accelerator Conf., (Chalk River, Canada Nov. 1976) AECL-5677.
5. M. J. Saltmarsh and R. E. Worsham (Ed.), "Proposal for an Intense Neutron Generator for Radiation Induced Damage Studies in the CTR Materials Program," Oak Ridge National Laboratory report ORNL-TM 5233 (January, 1976.)
6. B. L. Ioffe, et al., "The Scheme of a 14 MeV Intense Neutron Generator with Two-Frequency Deuteron Linac," proposal by ITEP (USSR), ITEP-118, Moscow 1977, Los Alamos Scientific Laboratory translation LA-TR-79-6 (1979).

7. D. D. Armstrong, E. A. Meyer, and J. D. Schneider, "FMIT Injector Workshop Notes," Los Alamos Scientific Laboratory internal report (Los Alamos, NM, July 12, 1978).
8. R. Beringer and R. L. Gluckstern, "A Family of Improved Linac Bunchers," 1964 Linear Accelerator Conference, MURA, July 20-24, 1964.
9. D. J. Warner and M. Weiss, "Beam Optics in the CERN New 50 MeV Linac," Proc. 1976 Proton Linear Accel. Conf., op. cit.
10. J. Claus, "Reduction of Losses in Linacs for Protons or Heavy Ions," 1977 Particle Accelerator Conference, Chicago, IL, March, 1977.
11. R. A. Jameson and R. S. Mills, "Factors Affecting High-Current, Bright Linac Beams," Los Alamos Scientific Laboratory private communication (April 1977).
12. W. P. Lysenko, "Equilibrium Phase-Space Distributions and Space Charge Limits in Linacs," Los Alamos Scientific Laboratory report LA-7010-MS (Oct. 1977).
13. J. W. Staples & R. A. Jameson, "Possible Lower Limit to Linac Emittance," to be published in the 1979 Particle Accelerator Conference Proceedings (San Francisco, California, March 12-14, 1978)
14. W. P. Lysenko, "Linac Particle Tracing Simulations," to be published in the 1979 Particle Accelerator Conference Proceedings, op. cit.
15. K. R. Crandall, "Transverse Emittance Growth in a Quadrupole in an rf Gap; Due to a Sequence of rf Gaps; Reduction of rf Gap Effect by Addition of Harmonic," Los Alamos Scientific Laboratory private communication (Jan-March 1978)
16. R. A. Jameson and F. Stagnaro (Editor), "Workshop Notes-HEDL Frequency Choice Workshop," Los Alamos Scientific Laboratory private communication (April 1978).
17. D. A. Swenson (compiler), "Semiannual Progress Report for the PIGMI Program at LASL--1 Jan - 30 June 1978," Los Alamos Scientific Laboratory (1978)
18. J. M. Potter, S. W. Williams, F. J. Humphry, and G. W. Rodenz, "Radio Frequency Quadrupole Accelerating Structure Research at Los Alamos," to be published in the 1979 Particle Accelerator Conference Proceedings, op. cit.
19. R. H. Stokes, K. R. Crandall, J. E. Stovall, and D. A. Swenson, "RF Quadrupole Beam Dynamics," to be published in the 1979 Particle Accelerator Conference Proceedings, op.cit.
20. D. D. Armstrong, J. C. Hyde, J. D. Schneider, E. A. Meyer, and C. Robert Emigh, "Tests of Intense Neutron Source (INS) Prototype," to be published in the 1979 Particle Accelerator Conference Proceedings, op. cit.
21. D. D. Armstrong, E. A. Meyer, J. D. Schneider, and H. L. Rutkowski, "Progress Report on Testing of a 100-kV, 125-mA Deuteron Injector," to be published in the 1979 Particle Accelerator Conference, op. cit.
22. J. E. Boers, "Computer Simulation and Experimental Results for a 130 kV, 80 mA Deuterium Ion Beam," Los Alamos Scientific Laboratory report LA-7265-C (May 1978).
23. D. Liska, R. Schamaun, C. Potter, C. Fuller, D. Clark, D. Greenwood, and J. Frank, "Design of the Accelerating Structures for FMIT," to be published in the 1979 Particle Accelerator Conference Proceedings, op. cit.
24. G. P. Boicourt and D. A. Swenson, "Choice of Geometry for the Alvarez Section of the FMIT Deuteron Linac," to be published in the 1979 Particle Accelerator Conference Proceedings, op. cit.
25. M. D. Machalek, E. A. Meyer, and L. S. Price, "The FMIT Accelerator Vacuum System," to be published in the 1979 Particle Accelerator Conference Proceedings, op. cit.
26. M. V. Fazio, H. P. Johnson, W. J. Hoffert, and T. J. Boyd, "A Proposed RF System for the Fusion Materials Irradiation Test Facility," to be published in the 1979 Particle Accelerator Conference Proceedings, op. cit.
27. K. E. Melson, J. A. Farrell, D. J. Liska, D. D. Chamberlin, M. T. Wilson, P. Giles, C. Potter, T. Cole, and C. Caldwell, Jr., "High-Energy Beam Transport in the Hanford FMIT Linear Accelerator," to be published in the 1979 Particle Accelerator Conference Proceedings, op. cit.
28. O. R. Sander and R. A. Jameson, "Recent Improvements in Beam Diagnostic Instrumentation," to be published in the 1979 Particle Accelerator Conference Proceedings, op. cit.