

THE SLAC LONG ION CHAMBER SYSTEM FOR MACHINE PROTECTION*

Max Fishman and Daryl Reagan
Stanford Linear Accelerator Center, Stanford University, Stanford, California

Summary

To protect the Stanford 3 km accelerator from damage caused by its own electron beam, a single ion chamber has been installed, which runs the whole length of the accelerator. The pulse train from the ion chamber is displayed on an oscilloscope, giving a representation of beam power loss along the machine as a function of distance from the injector. It also operates a system that shuts off the electron beam within 1 ms whenever the signal level exceeds a preset value.

Introduction

If missteered at high power, the SLAC electron beam can cause local melting of accelerator components in a fraction of a second. Even relatively low level irradiation of the accelerator waveguide will cause harm, gradually changing critical dimensions by altering the crystal structure of the copper. To protect the accelerator, a system has been installed which is based upon a single long ion chamber¹ that runs the whole 3 km length of the accelerator housing. The signal from the ion chamber operates equipment that turns off the beam when any local radiation level becomes too high.

The Long Ion Chamber

The ion chamber is assembled from some 20 lengths of 4.1 cm diameter RG 319/U coaxial cable, and pressurized to 1 atmosphere gauge with a mixture of A with 5% CO₂. The facing surfaces of the cable are bare copper spaced by a narrow spiral of polyethylene. The cable is supported by straps near the ceiling of the accelerator housing, 2 m away from the accelerator waveguide.

When high energy electrons strike the inner wall of the accelerator structure, a cascade shower is produced in the copper waveguide. The shower multiplicity is proportional to the primary electron energy. The flux of ionizing radiation and the charge collected in the ion chamber are thus proportional to the local electron beam power loss. An ionizing event gives rise to a negative pulse in the cable which splits, with one half the energy being propagated in the forward direction. The other half is propagated backward toward the injector. The backward pulse travels to the injector end of the cable, which is extended some 500 meters to form a delay line. It is there inverted and reflected by a capacitor, and returns along the cable, which is extended into the Central Control Room (CCR) and terminated. Each backward pulse arrives in CCR with a relative time delay which is proportional to the distance of its origin from the injector. In CCR the pulse train from the cable is

displayed on an oscilloscope (Fig. 1) and fed into a discriminator circuit.

Observation of the backward pulse train enables one to estimate the magnitude of beam power loss in various regions along the machine, and to establish the location of a beam scraping event to within a few dekameters. The parameters governing the space resolution are the electron collection time, $\sim 0.27 \mu\text{s}$,² the electron velocity in the accelerator, c , and the propagation velocity of the cable, $0.92 c$. The 0-50% and 10-90% rise times have been measured for pulses making a two way transit of the whole cable. They have been found to be approximately 0.1 and 3 μs , respectively, in agreement with results cited by Kerns, *et al.*³ The effect of the presence of free electrons and ions upon the propagation of signals in the cable has been estimated⁴ and found to be small for the ionization densities usually encountered in practice.

An important advantage of a single long ion chamber is its uniform sensitivity. This uniformity is somewhat impaired in this application by the presence of extra material such as quadrupoles, dipoles, and beam scrapers between the beam and the ion chamber, and by geometrical asymmetry. Multiple scattering of the beam and of secondary electrons tends to reduce the effect of axial asymmetry. When a 10 MW (peak) beam is steered so that it all strikes the inner wall of the accelerator in a distance of 20 or 30 m, a pulse about 1 v high is observed in CCR. By manipulating the location and orientation of missteering, it has been found possible to vary the pulse height through a range of about 30%.

The Discriminator and Pulse Tester

Whenever local beam power loss exceeds a preset value, typically 2 v for 360 pps operation, the discriminator system turns off the electron beam by operating the 1 ms tone loop system.⁵ The tone loop system responds to the loss of one or more input signals by interrupting tone signals in two channels. Absence of tone signal in either channel causes the injector to turn off within 1 ms. A pulse generator and logical gating circuits, indicated in Fig. 2, test several properties of the ion chamber system during each interpulse interval. In the test, a pulse is transmitted along the cable, its transit time to the injector end and back is measured, and it is verified that the reflected pulse indeed operates the discriminator.

The test circuit consists of a pair of bistable multivibrators, a clock and test pulse generator, and logical gating circuits. The

* Work supported by the U.S. Atomic Energy Commission

operation of the logic circuits can be understood with the aid of the state transition diagram shown in Fig. 2. Flip-flop A is set to State A whenever the signal exceeds the discriminator threshold. Flip-flops A and B are reset to state (\bar{A}, \bar{B}) by clock pulse CL-1. Flip-flop B is set to state B whenever CL-2 is coincident with state \bar{A} . During normal operation, the system cycles through state (\bar{A}, \bar{B}) , (\bar{A}, B) , (A, B) , (A, \bar{B}) , etc. A "fast" enable signal is generated by passing a signal corresponding to $(A \cdot \bar{B} + A \cdot B)$ through a low-pass filter. Thus during the brief 26 μ s cable transit time interval during which state (A, B) persists for normal operation, the low-pass filter maintains the "fast" enable voltage. However, if the transition from (\bar{A}, B) to (A, B) fails to occur, state (\bar{A}, B) will persist for 1.4 ms. In this event the enabling signal will decay below an acceptable value in approximately 100 μ s, thereby signalling a system fault and shutting off the tone signal to the injector. A simple pulse width detector measures the duration of state (\bar{A}, B) and produces an analog signal which is applied to a meter relay. Failure to arrive at state (\bar{A}, B) results in a meter relay current of zero. If state (\bar{A}, B) persists for approximately 26 μ s, the meter-relay reads within its high-low limits. Finally if (A, B) persists for a half cycle, the meter-relay reading exceeds its high limit setting. The meter relay is interlocked with other meter relays measuring ion-chamber high voltage and dc current and with a pressure switch actuated by the gas-pressure in the ion chamber. These relay circuits interrupt a "slow" enabling signal applied to the tone interrupt unit.

When a signal fault occurs, the system is set to state (A, \bar{B}) and the fast enable signal is removed within 100 μ s. A fault-latching circuit and redundant relay circuits continue to withhold the enabling signal even though the system again proceeds through its normal cycle after CL-1. The fault-latching circuits are manually reset to resume full operation.

The Positron Gate

When positrons are being made, a large signal is produced in the long ion chamber. The discriminator is accordingly provided with a gating cir-

cuit which acts to prevent the signal from the positron source from shutting off the injector. The positron gate is normally triggered only when the positron beam is in operation. Its time delay and duration are adjustable, so that the system can retain full sensitivity during those periods when no large burst of radiation is expected from the positron source.

System Reliability Experience

Since April, 1966, the system has been almost continuously available for operation whenever the beam has been turned on. There have been two operating failures, so far. A control potentiometer opened, and a meter relay failed. In both cases, the system failed safe. The principle cause for complaint about the system has been that it works, making it difficult to perform experiments which produce ion chamber pulses larger than about 18 v, the maximum possible discriminator setting. In some cases it has been possible to accommodate these experiments by using the positron gate. In other cases it has been necessary to disable the system completely.

References

1. W.K.H. Panofsky, SLAC Internal Report TN-63-57, Stanford Linear Accelerator Center, Stanford, Calif. (1963). H. DeStaebler, SLAC Internal Report TN-63-63, Stanford Linear Accelerator Center, Stanford, Calif. (1963).
2. B. Rossi and H. Staub, Ionization Chambers and Counters, McGraw Hill, New York, 1949, p. 14.
3. Q. Kerns, F. Kirsten and C. Winningstad, UCLRL Counting Note CC2-1, Lawrence Radiation Laboratory, Berkeley, Calif., revised, 1959.
4. D. Reagan, SLAC Internal Report TN-63-91, Stanford Linear Accelerator Center, Stanford, Calif. (1963).
5. T. A. Christie, SLAC Engineering Design Report, ED-122-004-R1, Stanford Linear Accelerator Center, Stanford, Calif. (1964). K. E. Brey Mayer, SLAC Internal Report TN-67-4, Stanford Linear Accelerator Center, Stanford, Calif. (1967).

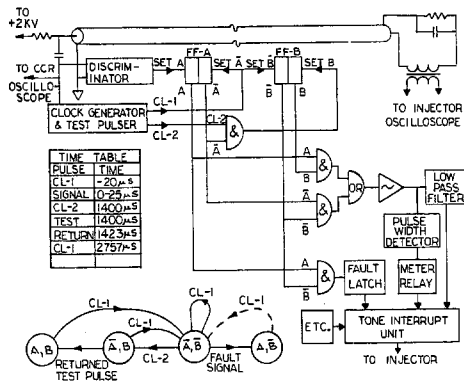

Fig. 1. Long ion chamber pulse trains as observed in CCR. The horizontal scale is approximately 4 μ s/cm. The lower trace shows evidence of beam blow up.

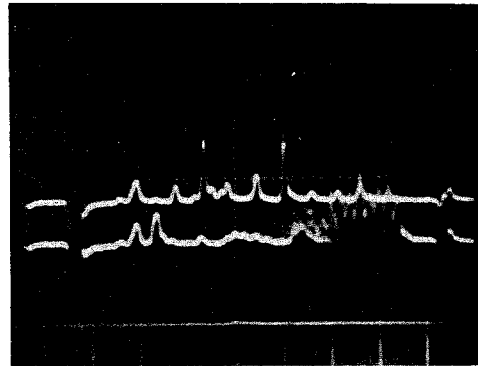

Fig. 2. Block diagram, timetable, and state transition diagram for the long ion chamber logic circuits.