

EXPERIMENTAL STUDIES OF THE OMNITRON ELECTRICAL COMPONENTS*

James W. Davis, William L. Gagnon, and Bob H. Smith

Lawrence Radiation Laboratory
University of California
Berkeley, California

February 3, 1967

Summary

A prototype resonator has been built and is under study. It tunes from 6.8 to 33 MHz and is designed to produce an accelerating gap voltage of 60 kV at 20 Mc. Sixty 30-in.-diam by 1/2-in.-thick ferrite discs are used. The resonator is excited by a final amplifier using an RCA 4616 tube designed to deliver a peak RF power of 300 kW.

The paper also discusses studies of the RF drive train and the master oscillator, which tunes continuously from 1.5 to 33 MHz. It is a beat-frequency oscillator using a crystal-controlled fixed oscillator and a varactor-tuned variable oscillator.

A ferrite magnet system, also under study, contains a coaxial, lumped-constant pulse line with a hydrogen thyratron switch tube coupled to a ferrite magnet. The pulse line uses ceramic capacitors and operates at one atmosphere of SF₆. The rise time is 100 ns, the pulse width 5 μsec, and the repetition rate 60 pps. Peak instantaneous power during the pulse is 200 MW; average power is 65 kW.

The Omnitron is a strong-focussing synchrotron and storage ring arranged in a configuration particularly suitable for the acceleration of heavy ions. During each acceleration period the RF system sweeps from 1.6 to 32 MHz. This range is too great for a single RF system, so two are used. The transfer between them is done on-the-fly at 6.8 MHz--the low-frequency system sweeps from 1.6 to 6.8 MHz, and the high-frequency system from 6.8 to 32 MHz. The high-frequency system presents the most severe problems, and so the initial work has been concerned with it.

The prototype high-frequency resonator is shown in Fig. 1, a and b. It is a two-cavity synchrotron resonator in which the case carries the ferrite bias current in a figure-eight configuration around the ferrite in order to avoid RF coupling. This technique was first described by Plotkin.¹ A transmission system is included which combines the voltages at the two resonator gaps and couples them to a single gap at the beam tube. This is necessary for heavy-ion acceleration because the space between particle bunches is short and varies with the different harmonic numbers that are used. The repetition rate of

the Omnitron is 60 pps. This high repetition rate requires a rather high energy gain per turn, so four sets of resonators are used. Each must produce a peak RF voltage of 60 kV.

Considerations concerning heavy ions and the large amount of beam handling necessary in the Omnitron restricts the straight-section space available for RF resonators. Therefore, one must use a larger ratio of outer to inner diameters of the ferrite discs than one would use for a proton synchrotron. This latter case is discussed by Kerns, et al.² The ferrite discs have an outer diameter of 30 in. and an inner diameter of 11 in.

The ferrite is cooled with Freon 11, the heat being transferred to water through a heat exchanger. Freon 11 was chosen as the coolant instead of oil or water because it transfers heat three times as well as oil and has comparable RF losses. While water transfers heat three times as well as Freon 11, the RF losses and high dielectric constant make it unsatisfactory.

The curves of resonant frequency vs ferrite bias current is shown in Fig. 2. The ferrite bias problem appears to be difficult. At full bias, about 15 000 A at 15 V are required, while at low current where the ferrite is unsaturated and the inductance is high, about 175 V are required. We have been investigating a two-power-supply method of providing the ferrite bias current. At the beginning of the sweep a high-voltage, low-current power supply is used; when the ferrite saturates, the load is transferred to a low-voltage, high-current power supply. The duty factor of the high-voltage supply is only about 2%, so it can be of comparatively modest size. A block diagram of the two-power-supply method is shown in Fig. 3.

A Kerns actuator³ and regulator are used to trim the ferrite bias current to a precise value. A small bench-top model of this bias system was built and checked out. Upon investigating, we found it comparatively simple to fire and turn off SCR's carrying high currents. A full-scale system is being designed at present.

The final RF amplifier for driving the resonator uses an RCA-4616 vacuum tube and is designed to deliver a peak RF power of 300 kW. Calculations assuming a Qμf product of 10¹⁰ for the ferrite indicates that about 150 kW of power will be required. This tube was chosen because it provides adequate power reserve and requires a particularly small amount of grid drive. The

power stated is achieved with a grid drive of only 275 V, the grid being driven only 25 V positive. The grid circuit is tuned by a ferrite resonator which tracks the RF frequency. The driver stage is being developed at present; it consists of a pair of RCA-4624 tetrodes operating in parallel.

The master oscillator (Fig. 4) sweeps from 1.5 to 32 MHz. It is a beat-frequency oscillator using a 100-MHz crystal oscillator heterodyned with a varactor-tuned, self-excited oscillator which tunes from 101 to 133 MHz. The circuit contains a second beat-frequency oscillator with the crystal oscillator operating at 100.1 MHz and the same variable oscillator as the first channel. This second channel produces an output frequency that differs from the first channel by 0.1 MHz. The second channel provides a signal for frequency conversion in instruments throughout the Omnitron. Thus, signals that are measured during the sweep can be heterodyned to a constant frequency of 100 kc and the information can be transmitted at this frequency.

Ferrite magnets are used on the Omnitron for high-speed beam switching. The basic system is similar to the kicker magnets on the AGC machines at Brookhaven and CERN, and the storage rings at Stanford.⁴⁻⁶ These all consist of pulse lines that discharge through high-speed switches to the ferrite magnet windings. The pulse line is arranged in a coaxial configuration and uses ceramic capacitors for energy-storage. The switch tube is a General Electric type ZT7005 hydrogen thyratron rated at 50 kV. The pulse line has a characteristic impedance of 2 Ω and is initially charged to 40 kV. The pulse current is 10 kA. The system was designed to rise to full current in 100 ns. An assembly drawing of the pulse line is shown in Fig. 5a, with its schematic on Fig. 5b, and a typical ferrite magnet in Fig. 5c.

The performance of the system was studied both experimentally and theoretically with a computer code called "MIMIC." This code displays the solution as a plot of the desired variable vs time. It is interesting to note the similarity between the computed system performance and that obtained experimentally, as shown in Fig. 6. The wave shape is adequate for the needs of the Omnitron, but further improvement would be desirable.

The most important problem, at present, is that of component reliability. The first problem we encountered concerned the terminating resistors. We found that the vibration associated with the high repetition rate and high currents fractured the 180-W Globar resistors (Carborundum Co., type 889SP). Reinforcing the resistors with epoxy-loaded tape stopped the breakage in the center section but did not help the breakage at the mounting terminals, which were essentially machined away by the vibration. We tried several different mounting techniques, but none were satisfactory. Finally, we decided to build the 70-kW resistor from 2-W carbon

resistors. We mounted 7000 Allen Bradley 10- Ω resistors on etched circuit boards in a series-parallel configuration to produce a net value of 2 Ω . Tests showed that when immersed in water, these resistors dissipate 20 W each--so far, operation has shown no deterioration of this resistor system, and we think this problem is solved.

The next problem we ran into was a water leak into the pulse-line chamber, which is filled with SF₆. The SF₆ atmosphere deteriorated sufficiently to permit an arc. Hydrofluoric acid and hydrogen sulfide were formed. The hydrofluoric acid attacked everything, making an unbelievably obnoxious mess. The capacitors were carefully washed in water and then dried in an oven. Two O-ring gaskets were installed between the water and the pulse-line compartment, and the space between them was pressurized with nitrogen at 150 psi. With this modification, the system ran for 24 hours; then there was another arc, apparently with water present, because again a large amount of HF was formed. It is not clear where the water came from, but we suspect that in the cleaning process, water became trapped inside the gradient rings. These had no drain holes. This error was corrected and the system reassembled.

Another component that requires further development is the ceramic capacitor. We have had quite a large number of failures, most of which have occurred at the bond between the terminal and the plating on the ceramic core. The terminal is machined from brass. The ceramic core is silvered and the terminal is soldered to it with soft solder. We have cut a number of the capacitors in half and have inspected the joint under a microscope after various amounts of operation, and the solder connection appears to deteriorate with time. This is probably caused by the motion produced by the electrostriction of the ceramic and the difference in the modulus of elasticity of the ceramic and the brass terminal. It would seem that this problem could be solved by connecting the terminal and the ceramic core with, for example, a piece of RF gauze or a thin metallic diaphragm. At present, our efforts primarily concern capacitor development and further work on the H₂O-SF₆ problem.

References

1. M. Plotkin, The Radio Frequency Accelerating System for the Brookhaven Attenuating Gradient Synchrotron, in 1960 IRE International Convention Record, Part 9, pp. 19-27, March 21, 1960.
2. Q. A. Kerns, G. S. Tool, and J. E. Katz, Ferrite Measurements for Synchrotron RF Accelerating System Design, IEEE Trans. Nucl. Sci. NS 12, 3, 185 (1965).
3. Q. A. Kerns, Rectifier System, U. S. Patent No. 2,579,235, December 18, 1951.

4. G. K. O'Neill and V. Korenman, The Delay Line Inflector, Princeton-Pennsylvania Accelerator Project Internal Report GKO'N-10, VK13, December 18, 1957.
5. B. Kuiper and G. Plass, On the Fast Extraction of Particles From a 25-GeV Synchrotron,

CERN Internal Report CERN-59-30, August 24, 1959.

6. E. B. Forsyth, The Fast Kicker of the AGS External Beam System, Brookhaven Internal Report (AGS) E. B. F. -3, October 27, 1964.

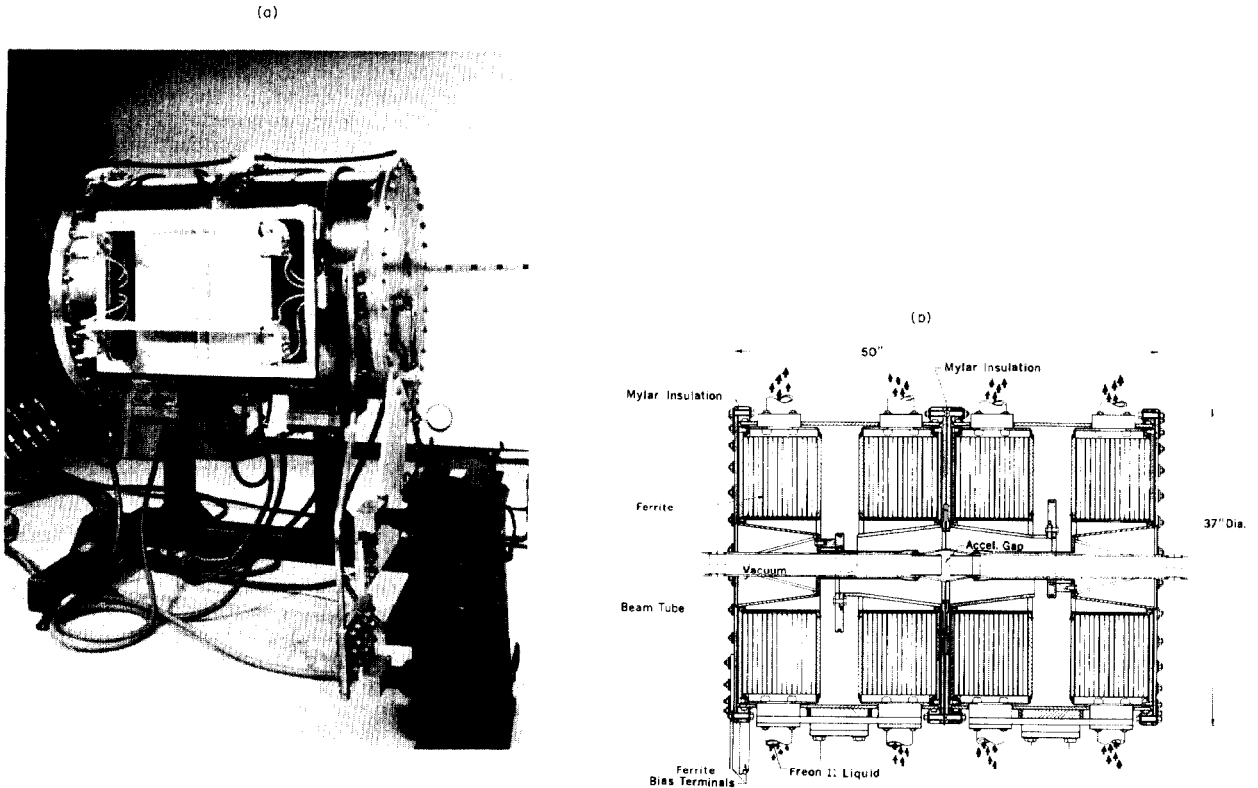

Fig. 1. (a) Prototype HF RF resonator. The resonator contains 30-in.-diam ferrite discs. The case carries the ferrite-bias current, which for the initial test was supplied by the transformer shown connected above. (b) Cross-section of the HF resonator. The output voltage of the two resonator sections are combined to excite a single accelerating gap. Freon-11 is circulated between the ferrite discs for cooling.

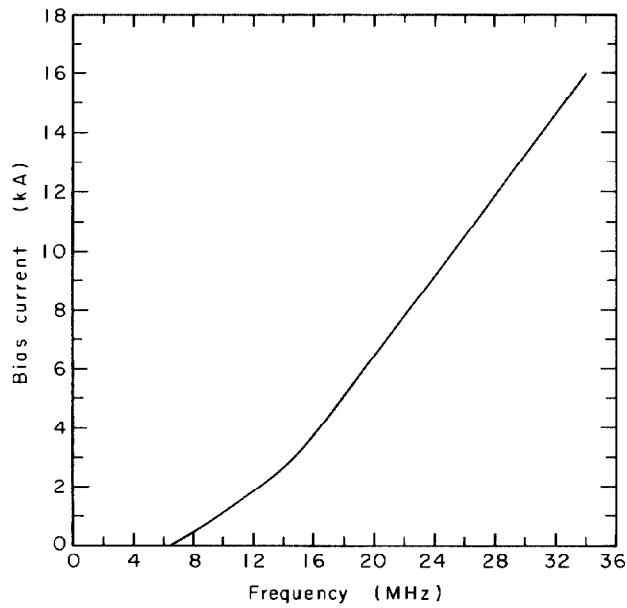

Fig. 2. Ferrite-bias current vs frequency for the HF prototype resonator.

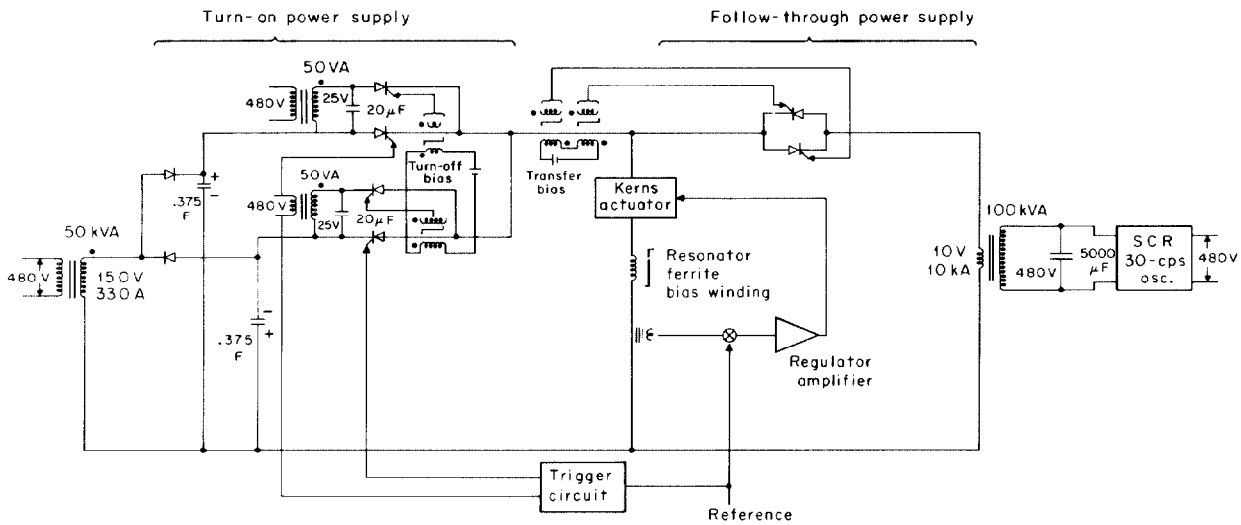

Fig. 3. Simplified schematic of ferrite-bias system. The ferrite bias uses two power supplies. A HV turn-on supply is used at the start of the sweep when the current is low and the inductance high. In about 1.5 ms, when the current reaches 1 kA and the inductance has dropped to about 5% of its unsaturated value, excitation is transferred to the low-voltage high-current follow-through power supply.

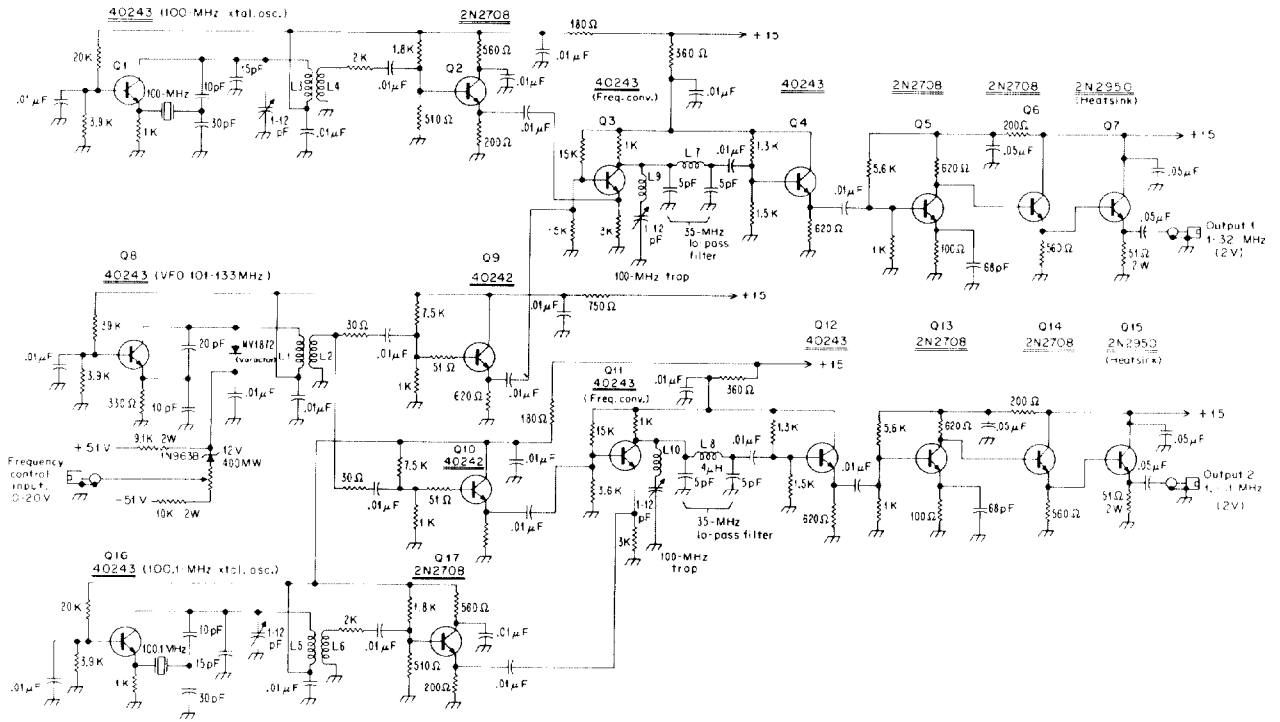

Fig. 4. Master-oscillator schematic. The master oscillator is a two-channel beat-frequency oscillator which produces an output frequency that is variable from 1 to 32 MHz. The frequency of the second channel is displaced from that of the first by 0.1 MHz. It is used for frequency conversion in instruments throughout the Omnitron.

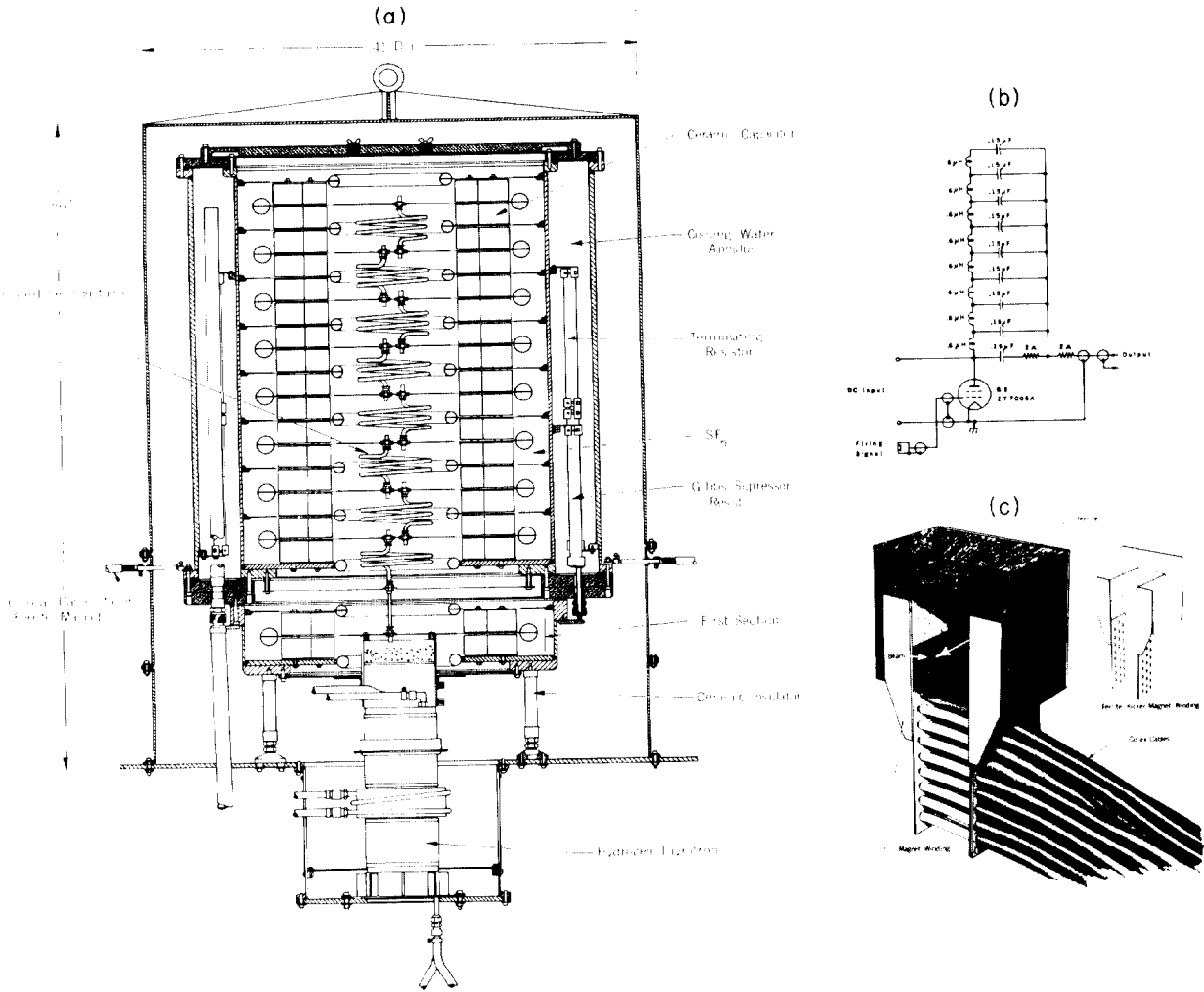

Fig. 5. (a) Ferrite-magnet power supply. Construction is coaxial in order to confine the rapidly changing magnetic fields. The pulse line is initially charged to 40 kV and operates in an atmosphere of SF₆. It produces a 5-μs pulse with a 100-ns rise time. The repetition rate is 60 pps. (b) Schematic of power supply. (c) Typical ferrite kicker magnet. This magnet produces a peak field of 2.5 kG over an area of 12 in² with a magnet gap of 2 in.

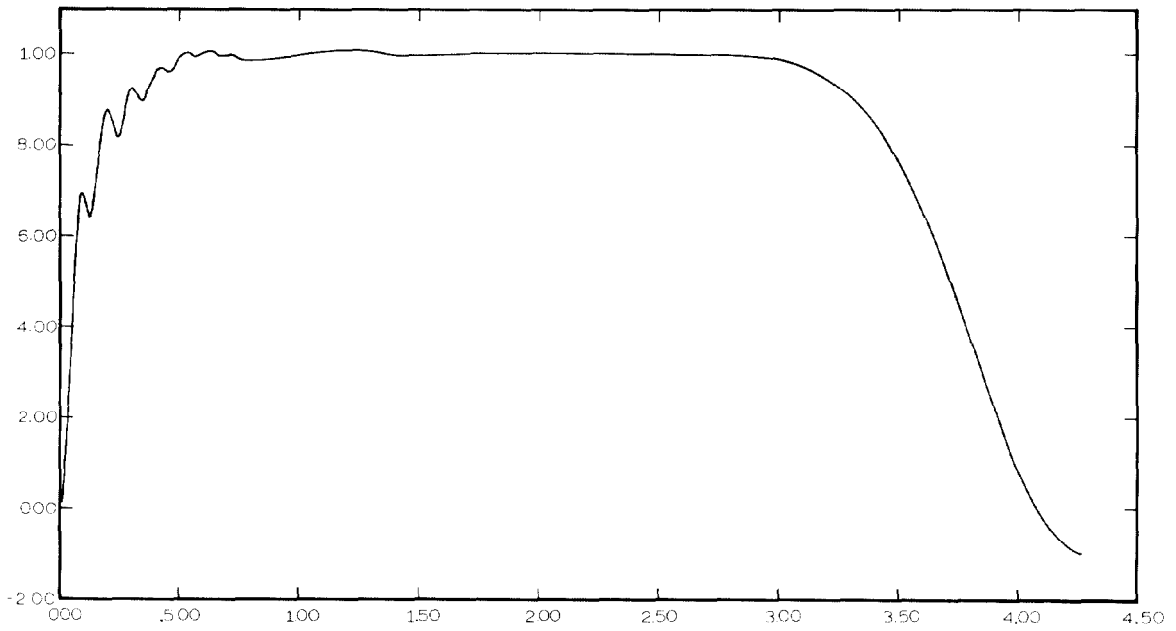
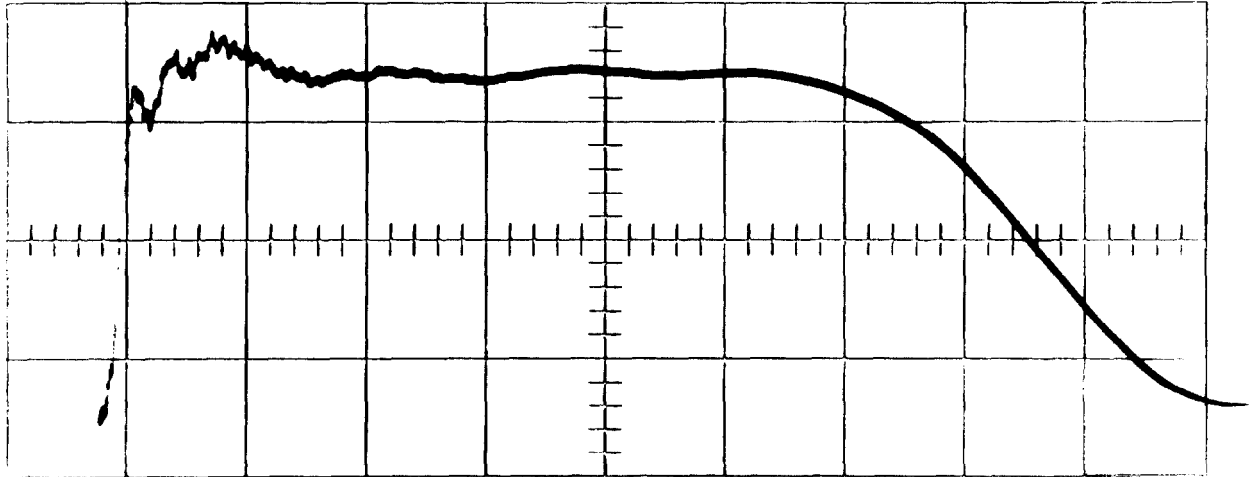

Fig. 6. Comparison of wave shape of magnetic field vs time, with a computer plot of the magnet excitation current vs time.