

INSTRUMENTATION AND CONTROLS FOR THE STANFORD LINEAR ACCELERATOR*

Lawrence H. Johnston
Stanford Linear Accelerator Center
Stanford, California

SUMMARY

We discuss the philosophy of an accelerator instrumentation system, and techniques which have been worked out for handling the various remote sensory and control functions required for proper operation of the accelerator. Lack of time prohibits more than incidental reference to philosophy of operation of the machine.

INTRODUCTION

Major contributors to the work reported here have been K. L. Brown, K. B. Mallory, K. E. Brey-mayer, D. D. Reagan, T. A. Christie, K. F. Crook, W. C. Struven, E. M. Mortenson, and J. A. Kuypers.

The problems which dominate the design of the remote instrumentation for this machine are its length (2 miles), and the potential noise environment caused by 240 fifty-megawatt klystron pulse modulators distributed along its length. A pair of control wires from the Central Control Room to a mean point on the accelerator costs \$150, so there is good reason to transmit as few signals as possible, and to consider ingenious schemes of multiplexing many signals on one wire pair.

Organization (Slide 1)

For control purposes, the 10,000 ft. length of the accelerator is divided into 30 "sectors". Each sector has a local Instrumentation Alcove, where the signals for that sector are collected and processed for long-distance transmission to and from the Central Control Room (CCR). This alcove is not normally manned in operation, but it serves as a local trouble-shooting center.

After processing, the residual signals listed on Slide 1 are transmitted from each sector to the CCR. A number of special signals are not mentioned.

With so many signals potentially available to the machine operator, how are they to be organized? There are far too many to be simultaneously watched by one man, or even by several men. The solution chosen is to have a sector control panel, which displays the analog and the status information coming from one sector of the machine only, and to switch this panel to show the signals from any desired one of the sectors. The same panel also contains the remote control push-buttons which actuate the variables being indicated, for the chosen sector.

Thus for trouble shooting when the beam has quit, a summary alarm signal would tell the maintenance operator "something is wrong in Sector 14". He would then switch his indicator/control panel to Sector 14, which might have a status

light tell him that the trouble in Sector 14 is that "Klystron water flow is below tolerance". A maintenance man would then be dispatched to Sector 14 to find out which particular water circuit is in trouble, and to fix it.

Local Controls

Almost all power equipment, e.g. the klystron modulators, is turned on and warmed up locally at the equipment, by travelling maintenance men. It is designed to be self-protected from faults, with automatic return to service if the fault is cleared. Inoperative equipment is indicated by status lights in the CCR, even though it cannot be turned on or off from that location.

The system is being designed primarily for control of the machine by human operators. However, the format of signals has been kept compatible with computer control, if this is desired later. It is planned that a small computer will be bought for the CCR, which is to be used initially for data logging. It will have sufficient capacity, however, to handle some control functions, such as beam steering and klystron replacement. After human operators learn how to perform these tasks, they may wish to teach them to the computer.

Transmission Lines

The transmission medium for the signals shown is twisted wire pairs, using techniques for noise immunity which have been found effective in the telephone industry. These are bound up in 50- and 100-pair cables which are quite economically available. Noise immunity is obtained by transmitting signals differentially across the wire pair in balanced fashion. Noise signals picked up equally by both wires of a pair do not then contribute to this differential-mode signal. Tests of the modulator noise picked up in such a cable show a differential pickup of about ten millivolts peak, as contrasted to a pickup of about one volt in the common mode (each wire with respect to ground).

SENSORY SIGNALS TO CCR

DC Analog Signals

Typical DC analog signals for this machine are "Steering Magnet Current" and "Manifold Vacuum". Each signal is transmitted simply as a zero to five volt potential on an individual wire pair. It is read at the CCR by a 2% accurate panel voltmeter. Noise pickup and cable leakage are small enough to permit readings to 0.1% accuracy, if a suitable voltmeter is used.

*Work supported by the U.S. Atomic Energy Commission.

In order to avoid interference from DC ground currents, the entire 2-miles long voltmeter circuit is grounded at only one point, usually one terminal of the voltage source.

Various multiplexing schemes were investigated for analog signals, but they were found to require terminal equipment costing much more than the corresponding individual long wire pairs.

Status Monitoring System

Status signals are two-valued functions. They are very easy to generate, and economical to transmit and display as an indicator lamp being on or off in CCR. Hence the attempt has been made to transmit as many of the required signals in this form, as possible. For example, we do not transmit a transformer temperature as an analog meter reading, if it is sufficient to inform the operator that the temperature is or is not within tolerance, by means of a status lamp.

Typical status signals are "Modulator Available/Not Available", "Waterflow OK/Not OK" and "Safety Interlock Chain Closed/Open".

Slide No. 2 shows the system being used. Each sector is provided with 100 status channels, which are time-division multiplexed and transmitted to CCR as a binary code, frequency shift signal on a single wire pair. Information from each channel is updated twice each second. The information is retained in memory circuits, to keep the indicator lamps continuously lit.

Beam Monitoring Signals (Slide No. 3)

In each sector, it is required to know the following beam parameters:

1. Horizontal beam position (X)
2. Vertical beam position (Y)
3. Beam Profile
4. Beam Intensity (Charge per pulse, Q).

A set of three microwave cavities located on the beam pipe in each sector provides three signals proportional to QX, to QY, and to Q. These are electronically conditioned and multiplexed to provide a succession of three pulses on a single wire pair. The pulses are proportional to X, to Y, and to log Q. One of these pulse triplets is transmitted to the CCR after every accelerator pulse, i.e. 360 times per second. The pulse level is about 10 volts maximum. The reason for using a log Q signal instead of simply Q, is to be able to measure beams over a wide dynamic range, even though the accuracy is correspondingly limited to about $\pm 30\%$.

In addition to the above, an accurate ($\pm 1\%$) signal representing total charge in a beam pulse is developed from a toroidal beam transformer. This signal is used to monitor beam loss along the accelerator. The Q signal is used to modulate a precise FM transmitter, to provide a stable noise-free transmission medium to the CCR.

These four signals from each sector go through one more process, not shown on the slide, before being displayed in the CCR. The X displacement signals from all 30 sectors are multiplexed in quick succession onto a CRT trace, to provide an X position steering profile for the entire machine. Similar treatment is given the Y position signal, and the log Q and the Q signal. These four position and intensity profile scopes provide the displays of the beam conditions along the machine.

From the magnetic analyzer in the beam switchyard, beam energy and beam energy distribution signals are developed and sent to CCR, to enable the beam operator to maintain the proper beam energy and spectrum.

Beam profile monitors are still being developed.

CONTROL SIGNALS FROM CCR

Remote Control System (Slide 4)

Almost all of the remote controls for accelerator functions have been successfully reduced to binary, i.e. pushbutton, controls, and a system has been developed to transmit them economically. Remote power supply voltages are raised by means of a remote motor, which runs as long as the pushbutton is held down. Typical Remote Control functions are "Raise/Lower Voltage", "Open/Close Hatchcovers", "Power On/Off".

Most of the control pushbuttons for one sector are located on the sector control panel, which also contains the corresponding status lights and analog meters to show that the control function is being carried out. This panel is switched from one sector to another, as explained previously.

The system adopted assumes that an operator will not need to operate more than one control at a time, and in only one sector at a time. The transmission system consists of six parallel binary wire pair channels, which are capable of selecting 6^4 different control functions at a sector. A seventh wire pair transmits the actual control command, which can be of either polarity to distinguish between "Up" and "Down", "Turn On" and "Turn Off", etc. The same seven wire pairs are bridged from one sector to the next for the entire length of the machine, and a separate pair to each sector from the CCR provides the means for the operator to seize the sector desired.

Trigger System (Slide 5)

A very flexible and accurate system has been developed for triggering the many items of equipment along the accelerator, which require precise timing. Examples of such items are klystron modulators, sub-booster modulators, injector gun, pulsed deflecting magnets, and particle detector gates. For most of these, timing precision needs to be about ± 25 nanoseconds.

Although the basic repetition rate of the accelerator is 360 pps, each accelerator pulse can be independently programmed as a distinct beam which may have a distinct beam energy, beam intensity, and a distinct destination among the several experimental setups reached via the beam switchyard. Up to eight distinct beams can be programmed. Although the most natural subdivision of 360 pps is into six 60 pps beams, the pattern in which the various beams succeed each other may be made as arbitrary as desired.

It is possible, for example, to program concurrently, 1) a beam for a bubble chamber experiment, to be repeated once per second; 2) a "null" beam on the pulse immediately before each bubble-chamber pulse, to reduce background; 3) a 10 pps beam into a special tuneup dump for tuneup of the next experiment; 4) a 60 pps beam to end station A for a scattering experiment; and 5) all the remaining pulses (actually 288 pps) to a meson factory.

In order to provide a high degree of flexible programming of triggers from the CCR without sacrificing precision of timing, the system shown in the slide is used. The precise timing for each item is supplied by sharp 400 volt "clock" pulses sent down to a single 1-5/8" diameter coaxial cable two miles long. A coaxial sampling transformer removes a small amount of signal energy at each station, to give a local 20-volt clock pulse. After suitable small delays, this signal is used to trigger the local item of equipment.

The control of whether each item is to respond to a given clock pulse is accomplished by providing a gating pulse originating in the CCR to go to each item. These gating pulses do not need to be very precise, and they can easily be transmitted on telephone wire pairs. A "Pattern Generator" in the CCR is programmed to provide the large number of patterns of gating pulses required to control the triggering pattern of each item which contributes to each beam.

In the slide, the pattern generator pulses are shown gating the trigger pulses for the klystrons of each sector. If a klystron is not to contribute energy to a given beam pulse, the system is arranged to trigger the klystron modulator 25 microseconds "late", after the beam pulse has passed. This enables the klystron and modu-

lator to keep operating at a regular rate, and to keep warmed up, even though its contribution to the beam energy may need to be irregular, as controlled by the gating from the gating pattern generator.

Accelerator Beam Protection System

In order to indicate places on the accelerator pipe where the beam may be striking the walls, a radiation detecting system is required. The beam has sufficient average power (10^6 watts) to melt through the copper wall of the disc-loaded waveguide in a few seconds, if it is badly missteered. The radiation detector is supposed to pick up the multiplied beam showers scattered outside the pipe, and shut off the injector gun before the next machine pulse.

(Slide 6) The novel detector invented for this purpose consists of a 2-mile long ionization chamber laid out parallel to the accelerator pipe, and a few feet from it. This provides continuous linear coverage along the accelerator. The long ion chamber is in the form of an argon plus CO_2 -filled commercial coaxial transmission line, 1-5/8" in diameter. This coaxial line not only serves to pick up an ionization signal, but also to indicate the position of the radiation pulse along the 2 miles of the accelerator, by the time required for the signal to reach the "upstream" end of the line. Notice that the time difference for radiation signals from different distances along the coax is one microsecond per 500 feet, the time at the speed of light for the electron beam to advance 500 feet down the accelerator pipe, plus the time for the signal to return 500 feet back up the coax.

The Ion Chamber signals are displayed on an oscilloscope, which provides a good profile of the accelerator's radiation. In addition the signals automatically cut off the injector gun, if they exceed a pre-set threshold.

ACKNOWLEDGEMENT

It is a pleasure to thank M. Sands for many valuable suggestions.

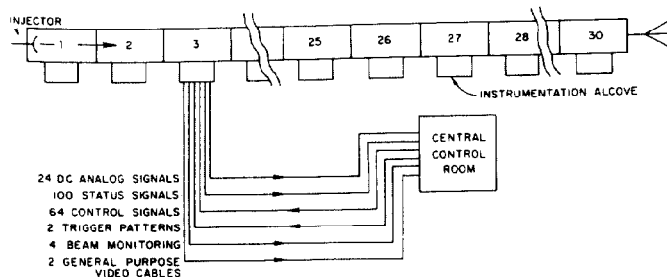

Fig. 1. Remote Signals from/to one sector.

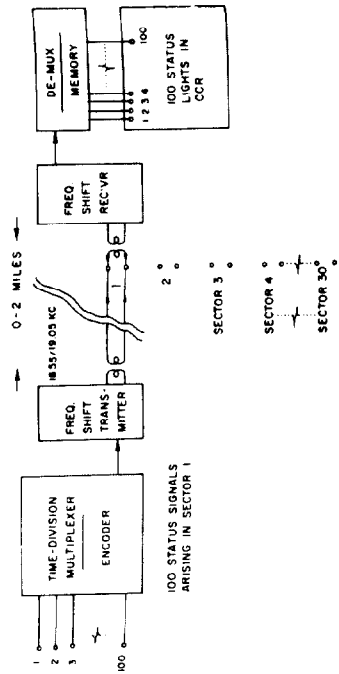

Fig. 2. Status Monitoring System.

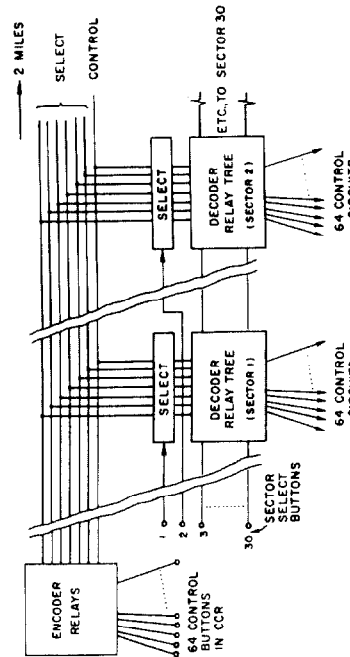

Fig. 4. Remote Control System.

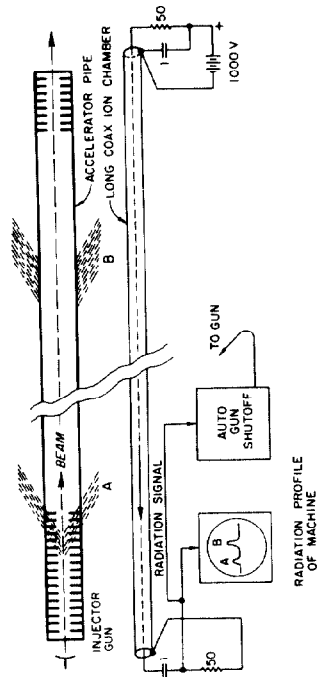

Fig. 6. Long Ion Chamber for Accelerator Beam Protection.

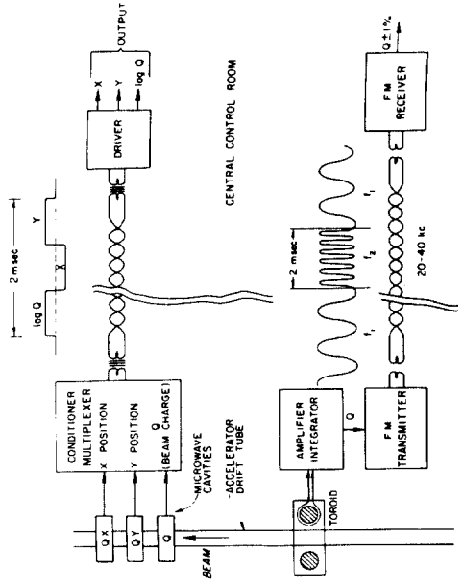

Fig. 3. Beam Monitoring Signals from each sector.

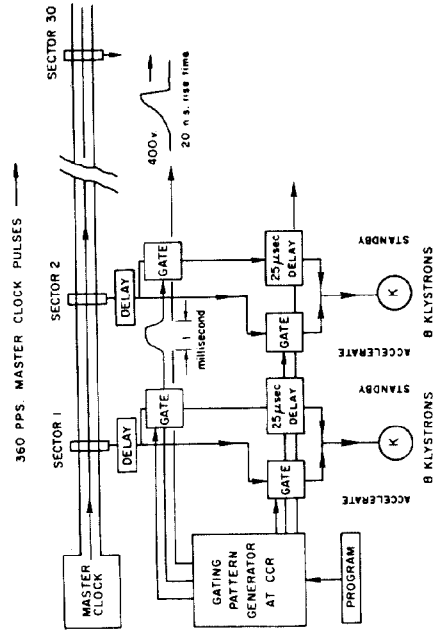

Fig. 5. Trigger System.