

# ULTRA STIFFNESS AND ULTRA LOW WAVING LM GUIDE

Authors: Akimasa Yoshida<sup>1</sup>; Martí Miret<sup>2</sup>

1: THK GmbH, Engineering Division, Senior Manager; 2: THK GmbH, Sucursal en España, Branch Manager

## Abstract

Since the launch by THK of the first Linear Motion Guide in 1972, these products have evolved in order to overcome different challenges. A current challenge consists on improving the precision of THK's products up to a nanometric scale. Optimizing the internal design of the block of a linear guide according to concrete specifications can reduce the waving phenomenon caused by the changing load condition of the rolling body in the block. However, this optimization is not enough for improving the precision of the LM Guides in a microscopic level. Increasing the number of effective balls by reducing their diameter, expanding the length of the block and increasing the number of rows in the Guide is a solution that allows a high increase of the rigidity and the reduction of the waving to the desired level.

## II. Theory of load distribution

In order to know how much the table would deform its postural change by the load and moment influenced to it, it is necessary to know the load distribution of the block interior. Therefore, THK uses the theory of load distribution.

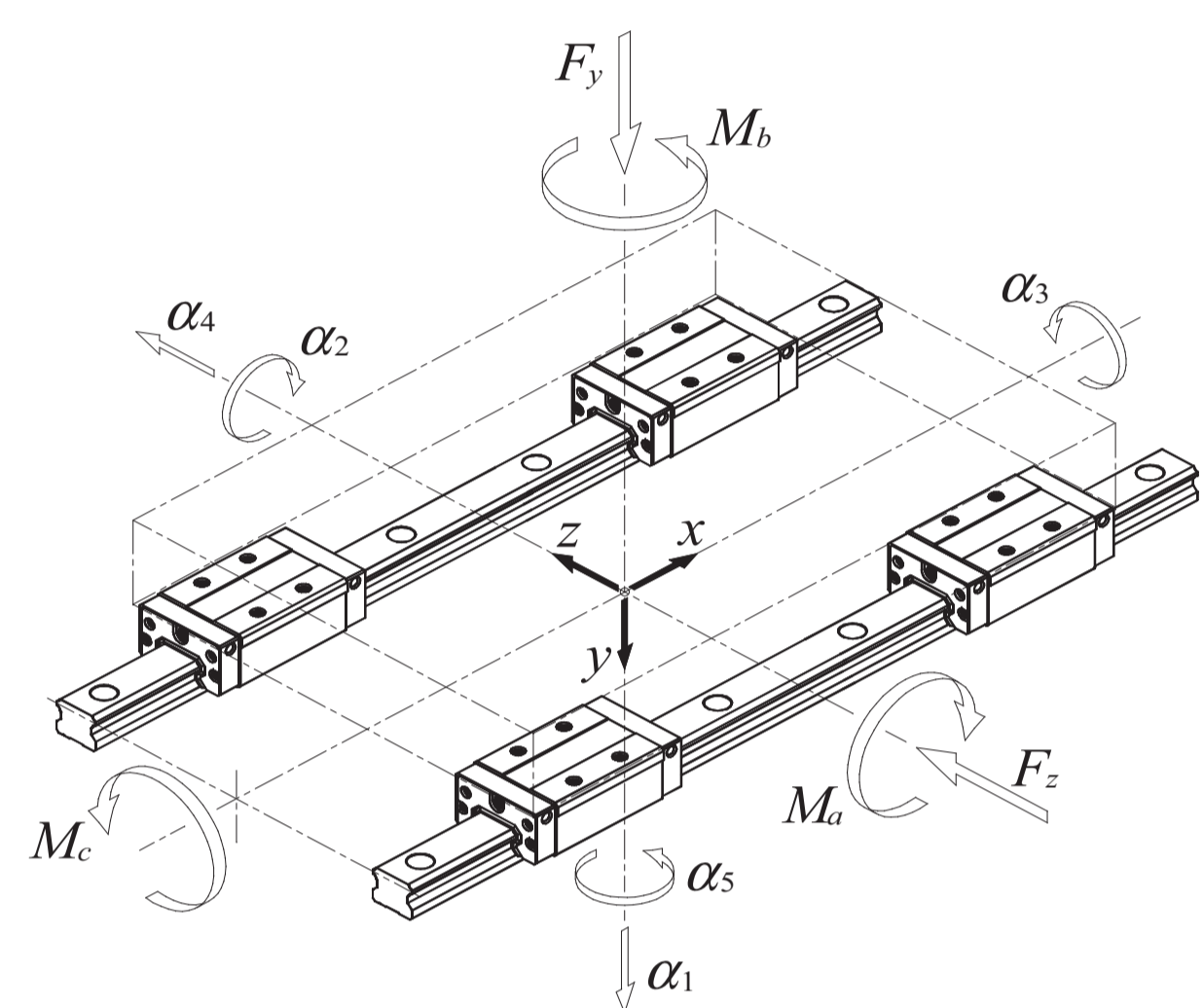

## IV. Optimized design

The initial solution for minimizing the waving consists on determining the optimized design of the block interior for meeting the clients specification

## V. Precision improvement of the LM Guide

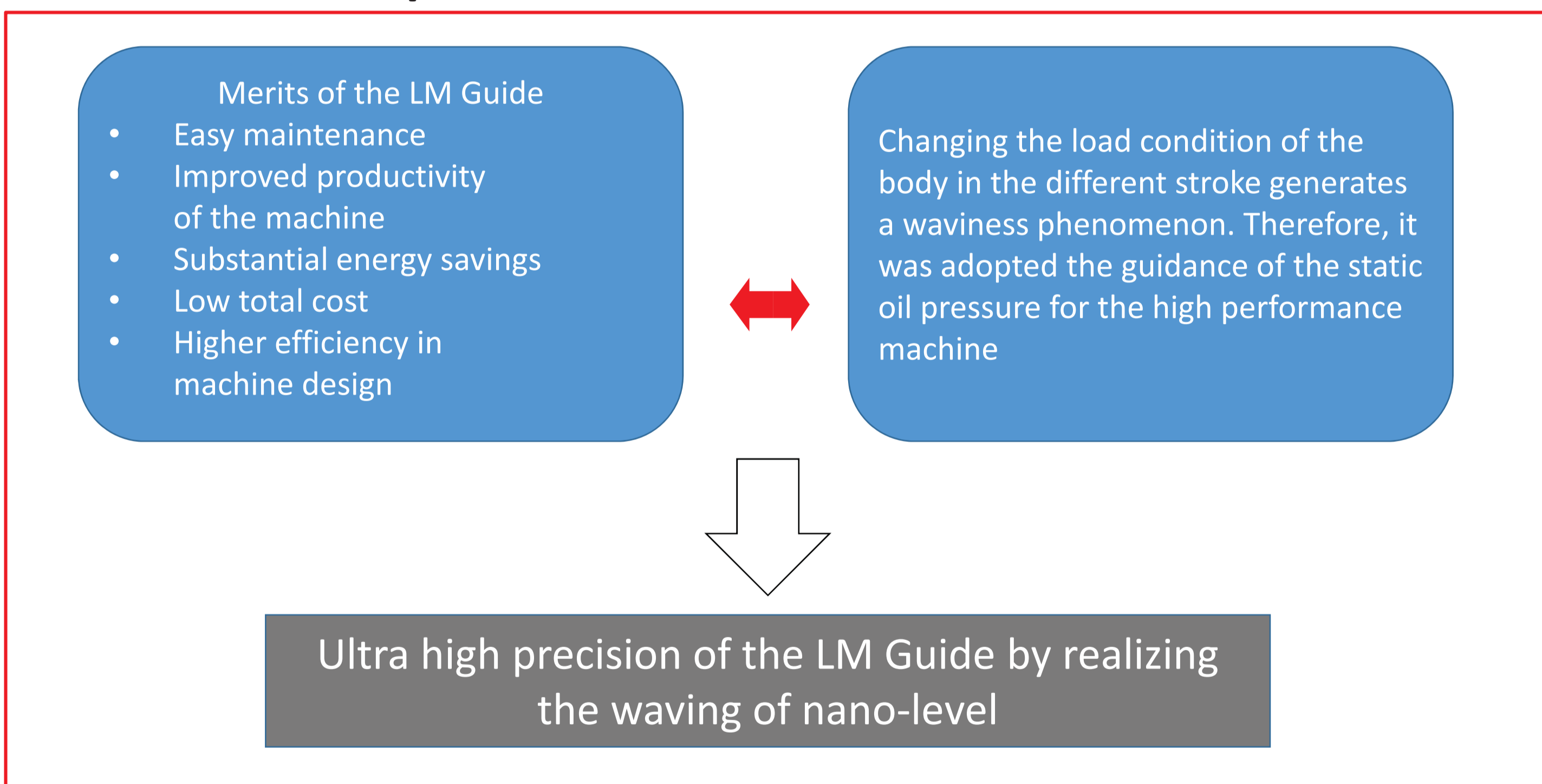

## VI. How to minimize the waving

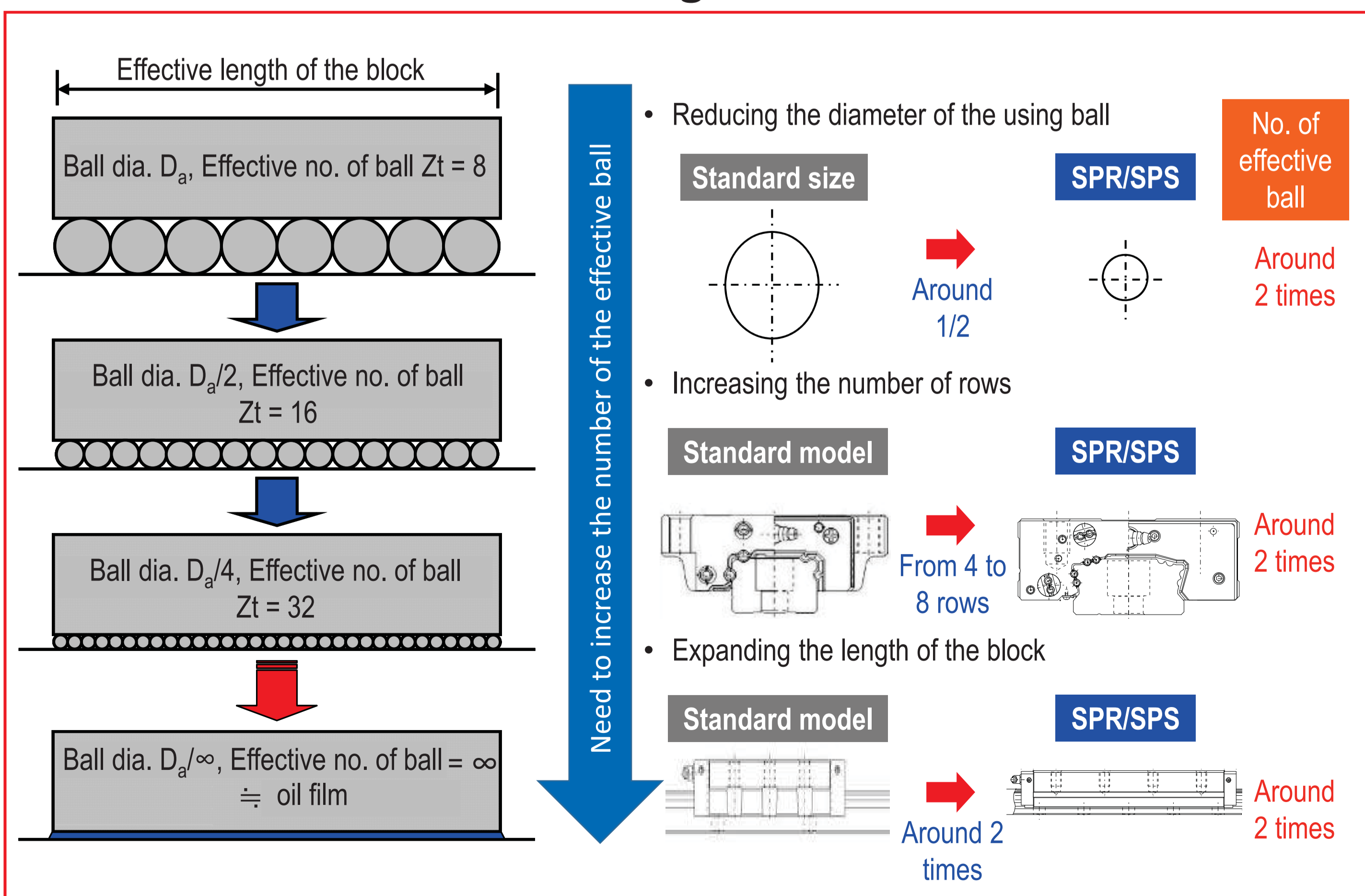

## I. Geometric accuracy of motion

**Straightness** indicates the range of how much the table movement deviates from the ideal line.

**Waving** shows the microscopic wave where it characteristically appears in the rolling motion guidance of the infinite circulation.

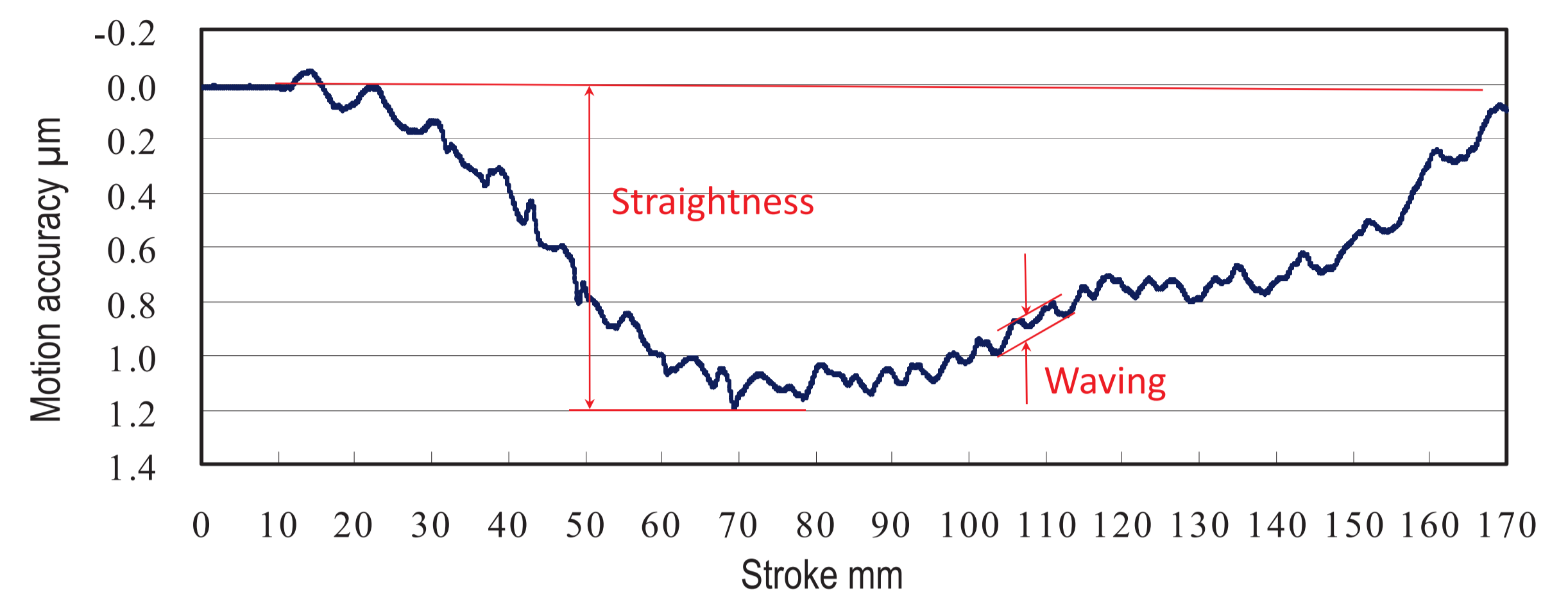

## III. Generating factor of the waving

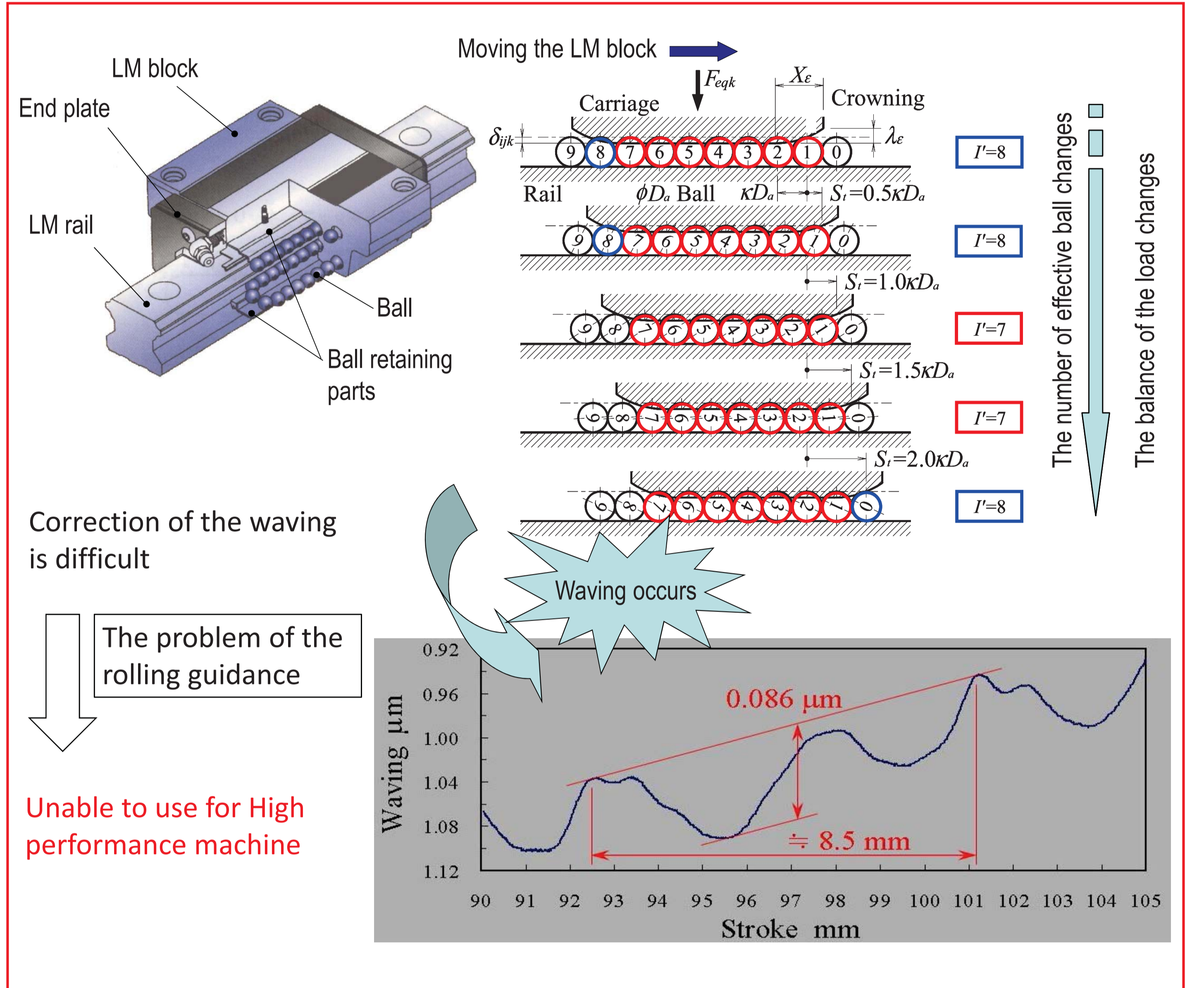

## VII. Advantages

• Increase of the effective balls around 8 times

• High accuracy & Super low waving

• High accuracy in rolling guide

• 80% reduction in waving

• Super high rigidity & High load rating

• Higher rigidity than roller guide

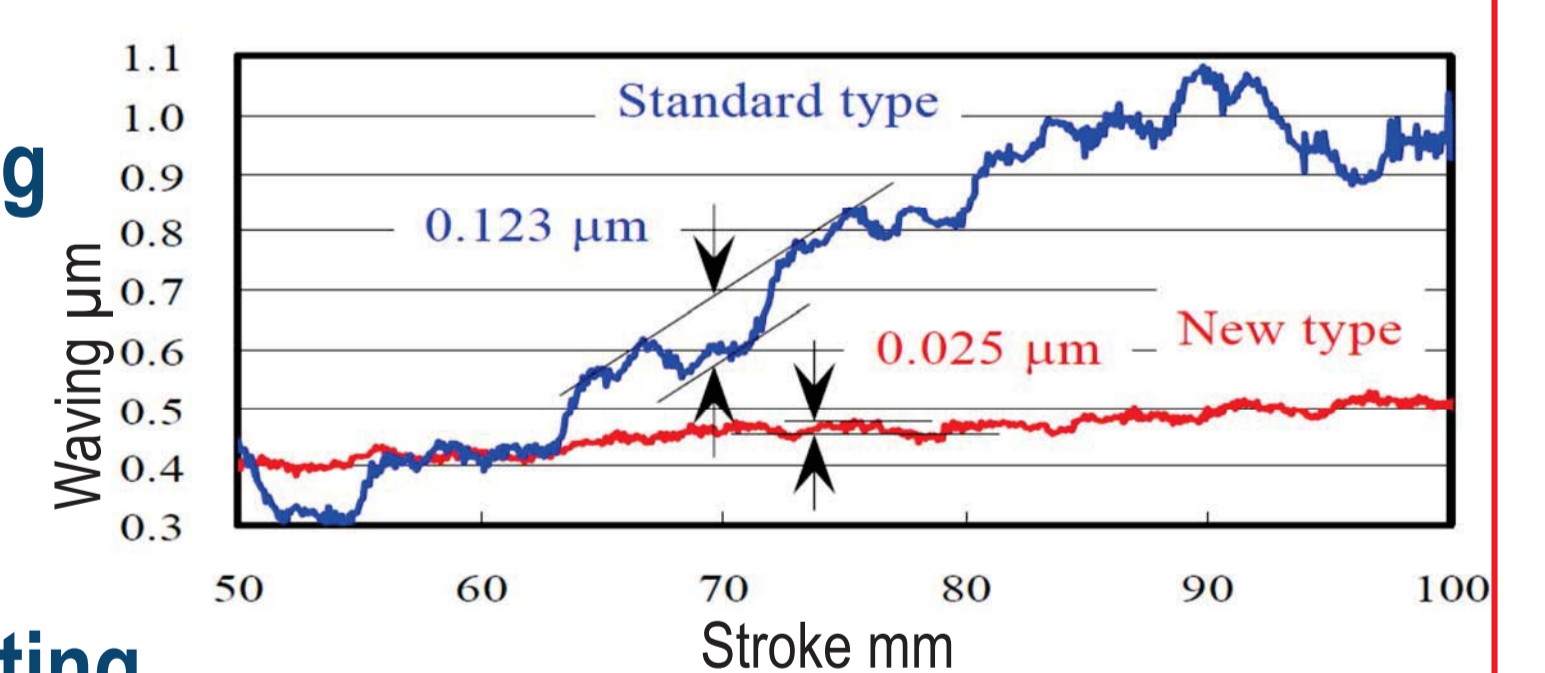

## VIII. Experimental test

