

Cam mover alignment system positioning with wire position sensor feedback for CLIC

Juha Kempainen¹, Zbigniew Kostka and Hélène Mainaud Durand
CERN, 1211 Geneva 23, Switzerland

¹also at Institute of Machine Tools and Manufacturing, ETH Zürich, Zürich, Switzerland

Introduction

Compact Linear Collider (CLIC) imposes stringent pre-alignment requirements [1, pp.602]. They lead to main beam quadrupole (MBQ) positioning requirement of

- $\pm 1 \mu\text{m}$ in vertical and transversal in both ends of a single quadrupole as well as
- 100 μrad in roll

It has been demonstrated that this can be achieved using cam movers and an iterative algorithm [2]. Fig. 1 shows CLIC MBQ and its mechanical stabilization system mounted on cam movers. System characteristics:

- MBQ and stabilisation system dimensions 460 × 510 × 1920 mm (X × Y × Z), weight 570 kg
- cam mover travel ± 3 mm, resolution < 50 nm

The cam movers were delivered with control electronics which did not allow trajectory manipulation during motion. Therefore, *new control system was developed*.

The new control system allows real-time alignment sensor feedback and trajectory modification during motion. The goal was to *reach target in one movement*. The control system also has three iterative motion control algorithms for the case where fast alignment sensor acquisition is not available.

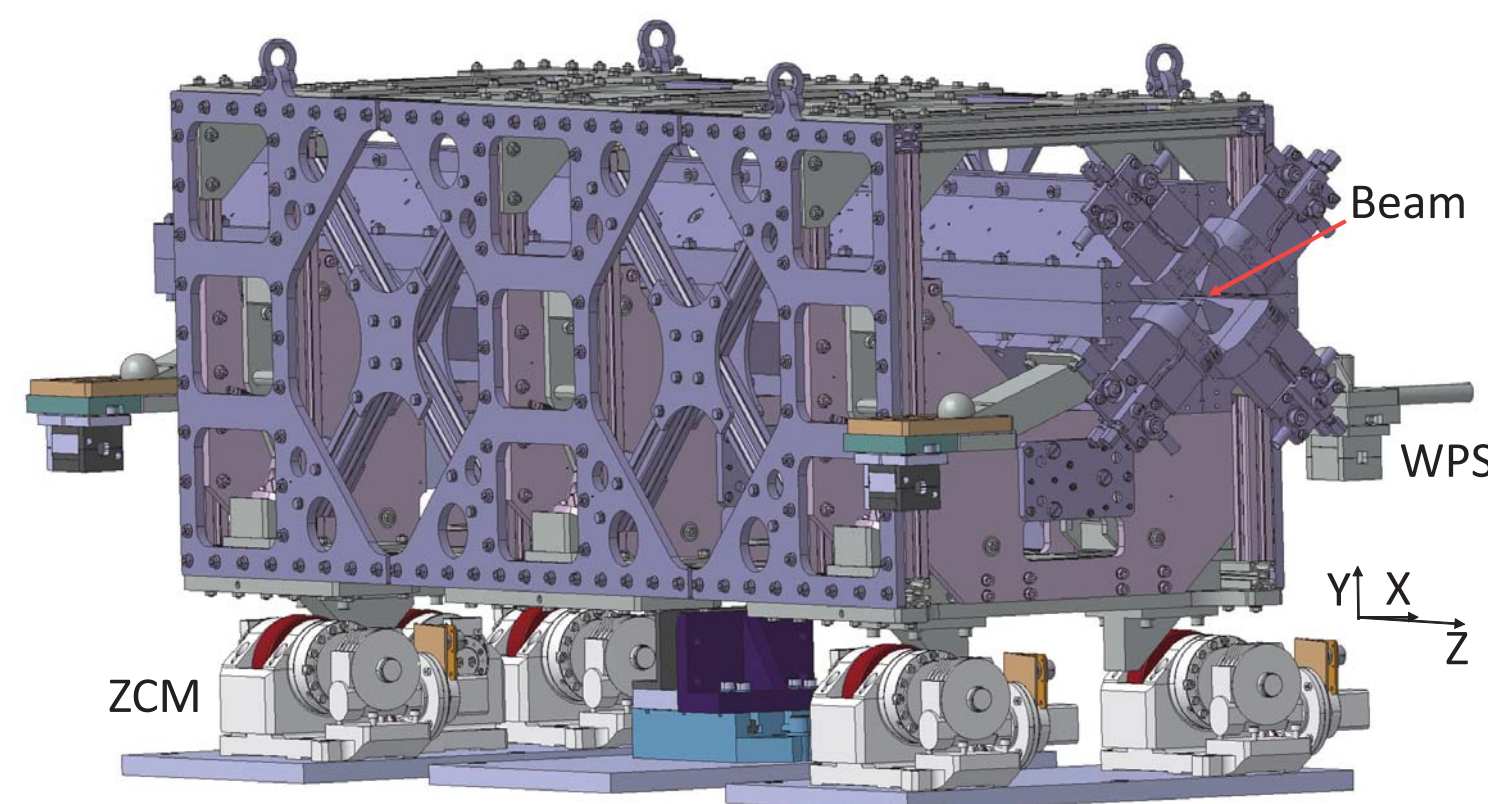

Figure 1. CLIC MBQ and its stabilisation system mounted on cam movers.

Tests

The four positioning algorithms were tested and compared. It was noticed in previous study that positioning deviations caused by uncertainties in the 5 DOF cam mover system's kinematic model grow with distance from reference position. Therefore, the tests concentrated on target positions near the travel extremities.

A test of 136 sequences was repeated using each of the algorithms. The sequences covered different offset combinations as well as roll targets. Each target was considered reached when deviation was below 1 μm in x- and y-offsets at both ends of the girder and roll deviation was below 5 μrad .

All positioning algorithms reach the target within tolerances so movement time is used as comparison metric. Fig. 4 shows a sample of 20 sequences. Movement time is the total time it takes to reach the target. Trajectory calculation time is not accounted for and it is on average 2 % of total time for Synchronous PTP and Predictive movement and 5 % for Straight-line and Complex movements.

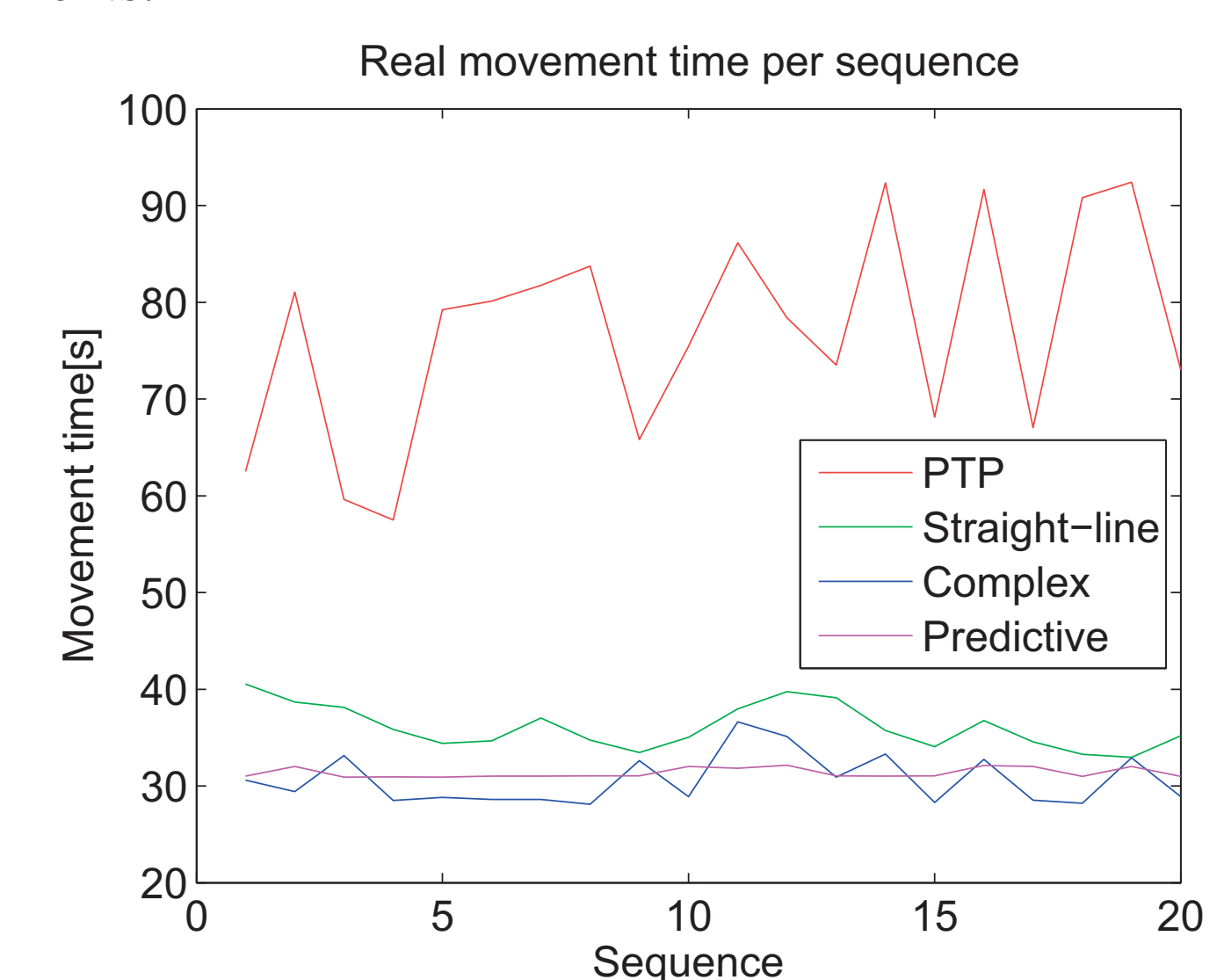

Figure 4. Comparison of execution times of four movement types.

Predictive movement was then tested with three stop condition parameter sets and reduced amount of sequences. The parameter sets were the original (Set 1), the tightest possible so that all targets were reached (Set 2) and a compromise set between the two others (Set 3). The results are given in the table below. Average deviations are not presented as there was no significant difference between the sets. The second line is average positioning time relative to Set 1.

	Set 1	Set 2	Set 3
Maximum deviations	x-offset 1.0 μm y-offset 0.4 μm roll 2.0 μrad	x-offset 0.5 μm y-offset 0.4 μm roll 1.3 μrad	x-offset 0.9 μm y-offset 0.5 μm roll 2.5 μrad
Avg time	-	+13 %	+1 %

Test setup

A girder simulating a CLIC MBQ was mounted on five cam movers, as shown in Fig. 2. The cam movers control five DOF (all but along the beam). Two stretched wires are installed on the mock-up and four WPS sensors measure transversal and vertical offsets. The setup is shown in Fig. 3. The five DOF position of the girder is calculated from the redundant WPS data through a least squares algorithm. The measurement system is out of scope but the uncertainty is approximately 1 μm in relative and 5 μm in absolute.

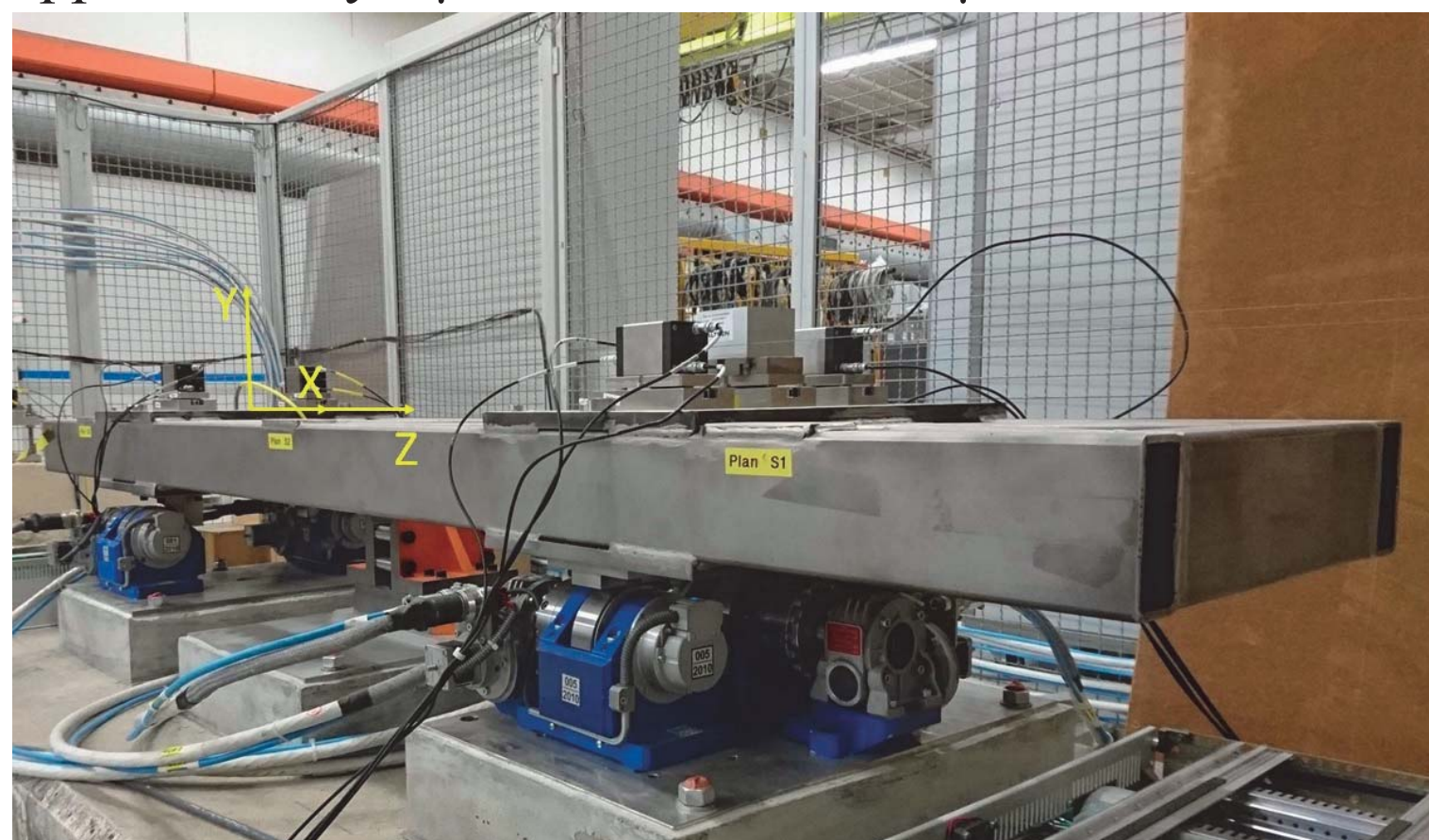

Figure 2. Cam mover mock-up.

The control electronics are based on modular National Instruments (NI) CompactRIO architecture. The controller is NI cRIO-9068 and it is equipped with two SISU-1004 modules to control the five cam movers (stepper motors), two SEA 9521 modules to read absolute encoders (one per cam mover) and an NI-9207 module to do fast acquisition of the four WPS sensors.

The software is divided in three layers.

- The user interface is running on regular LabVIEW on a host PC
- All calculations are done in the cRIO-9068 processor and the program layer is written on LabVIEW Real-Time
- The third layer communicates between the acquisition and control modules and the real-time layer and it is written in LabVIEW FPGA and NI SoftMotion.

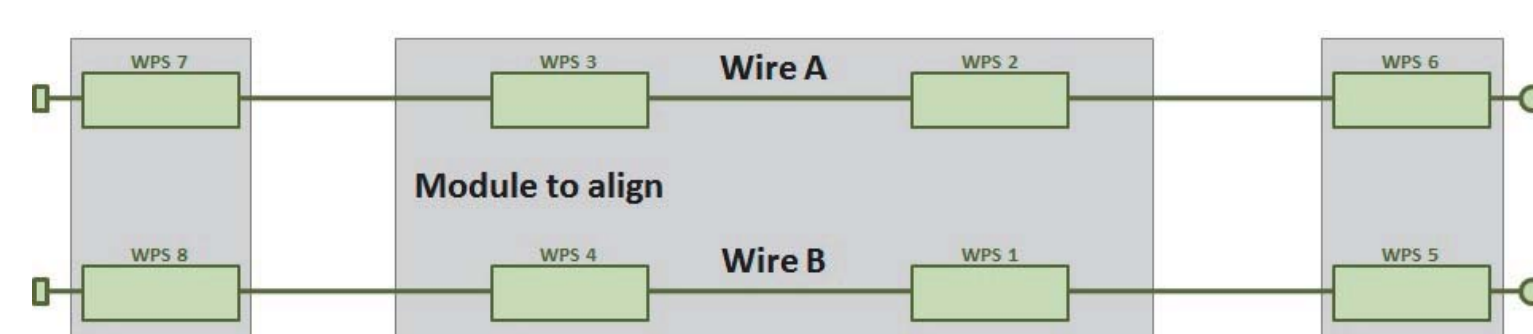

Figure 3. Alignment sensor configuration.

Positioning algorithms

Iterative algorithms

Iterative means that the target position is calculated through a kinematic model and the cam movers are driven to the target. The girder position is then measured and the positioning error is corrected in another movement. This is repeated until the target is reached within specifications.

Synchronous PTP

- Kinematic model gives cam target angles but *no trajectory*
- NI SoftMotion synchronises cams

Straight-line movement

- Trajectory is calculated completely before a movement
- No monitoring during motion

Complex movement

- The first iteration is executed as in Straight-line movement
- The next ones as in Synchronous PTP.

Predictive movement

The fourth algorithm uses alignment sensor feedback during motion. This means that target position can be reached in one movement even with non-perfect kinematic model.

- Part of trajectory is calculated before movement.
- During motion, trajectory is updated every 1 s

Conclusions

It was demonstrated that the CLIC positioning requirements for MBQ alignment stage can be met in one movement by using feedback directly from alignment sensors. This predictive movement was compared to iterative algorithms and it performed well both in level of deviation and in positioning time. A trade-off between positioning accuracy with regards to feedback and positioning time can be made depending on requirements.

When applied to a specific system, the predictive movement algorithm can be made faster, especially if there is very little play in the cam movers. Then overshoot is allowed and more aggressive trajectory can be applied.

Literature cited

- [1] M. Aicheler et al., "A Multi-TeV linear collider based on CLIC technology: CLIC Conceptual Design Report", CERN-2012-007
- [2] J. Kempainen, S. Griffet, R. Leuxe, H. Mainaud Durand, J. Sandomierski, M. Sosin, "CLIC main beam quadrupole active pre-alignment based on cam movers", in *MEDSI*, 2012.



Institut für Werkzeugmaschinen und Fertigung
Institute of Machine Tools and Manufacturing

