

DESIGNING THE PHOTON BEAMLINE FRONTENDS IN THE PETRAIII EXTENSION PROJECT

Hilmar Krüger*, W.A. Caliebe, M. Degenhardt, M. Hesse, F. Marutzky,
H.B. Peters, R. Peters, M. Röhling, H. Schulte-Schrepping, B. Steffen
Deutsches Elektronen-Synchrotron DESY, 22607 Hamburg, Germany

Abstract

The new insertion device beamlines in the PETRAIII extension project are arranged in three new sector types. The following will present the designs of the photon beamlines frontends for these sectors. The designs are based on the original design concept developed for the photon beamline frontends at PETRAIII. The aim of this generic approach was to minimize the number of specialized components for all beamlines. The existing girder concept allows a fast and reliable installation phase. The newly designed frontends aimed at using the same proven components and minimizing of the number of girder variations.

There will be 4 new sectors with two undulator IDs in each sector. The canting angle between the undulators was increased from 5 mrad to 20 mrad in difference to the generic beamlines. Additionally, two of the straight sections are modified. One straight section will be transformed in a side station sector with a 1 mrad canting angle. The other straight section with a 40 m long damping wiggler section will be used as a single beamline with a hard X-ray source. The modifications of the original frontend design, the components and the deviations between the sector types are being presented.

INTRODUCTION

For the next step in the development of PETRAIII as a synchrotron radiation source the PETRAIII extension project added up to 10 further insertion device beamlines located in two new additional buildings [1]. The beamlines are arranged in three new sectors types with different layouts to the PETRAIII in the Max von Laue experimental hall. This includes the layout of the frontends of the beamlines in the new tunnel. One of the three sector types contains two beamlines with one new generic frontend for the PETRAIII extension project with an increased canting angle from 5 mrad (PETRAIII) to 20 mrad. Additionally, two of the straight sections are modified. One straight section will be transformed in a side station sector with a 1mrad canting angle (P21) [2]. The other straight section with the 40 m long damping wiggler will be used as a single beamline with a hard X-ray source (P61) [3].

The reasons for the new layout are a different topology of the machine, the space available in the tunnel and the crane system for the transport of the components. This leads to an increased distance between the source of the beamline and the beginning of the girder frontend from at average

4.5 m to more than 35 m. In this section the photon beam is guided only in a UHV tube with vacuum pumps and a mask system. The distance between the beamline source and the optic hutches in the new halls are 50 m for the new generic beamline, 77 m for the side station beamline and 90 m for the the damping wiggler beamline.

GENERIC PHOTON BEAMLINE FRONTEND FOR PETRAIII EXTENSION PROJECT

The aim of the design concept of the old generic frontend as well as the new generic frontend was to minimize the number of specialized components for all beamlines [4, 5]. Additionally a second objective was to use the existing girder concept for PETRAIII with only small adjustments. The already existing girder concept allows a fast and reliable installation phase and is robust and versatile during commissioning and user operation [6].

The major difference of the new generic approach is the change of the canting angle between the two beamlines of one sector. The sector exist 4 times with two undulator IDs in each sector (P22-P23, P24-P25, P62-P63 and P64-P65). The large horizontal gap between the two beamlines in the girder frontend allows the use of a separate girder system for each beamline per sector (see Fig. 1 at the bottom). The classic generic approach required components for both beamlines per sector on one girder and therefore complex girders. In the new approach the use of only single beamline girder was possible. The only difference in the new generic designs was one additional tube in one beamline to align the girders for a better accessibility during installation and maintenance in the tunnel.

Due to some minor adjustments to some components and the integration of additional components (e.g. water cooled CVD diamond screen) it was necessary to change the arrangement of the components on the girders. Thereby only one girder design of the generic approach for PETRAIII could be re-used. In the the new generic design only four different girders types are used instead of eleven different girder types.

Common to all frontend designs and new in contrast to PETRAIII is the use of the water cooled CVD-diamond fluorescent screen with an attached CCD camera system. It is installed on the first girder in front of any other component. This new component allows to image the footprint of the white beam. Also new and common to all beamlines is the modified filter chamber. Now a CCD camera system is attached as well. Right behind the vacuum diagnostic

* hilmar.krueger@desy.de

Content from this work may be used under the terms of the CC BY 3.0 licence (© 2016). Any distribution of this work must maintain attribution to the author(s), title of the work, publisher, and DOI.

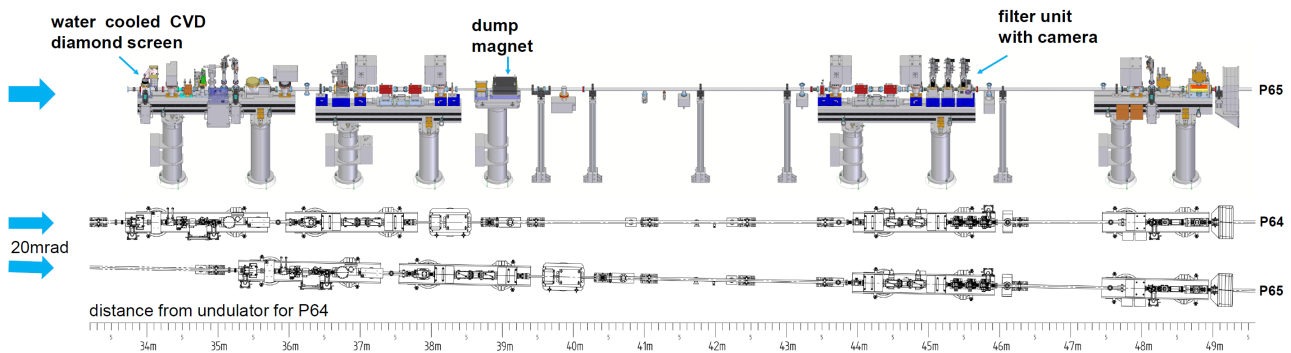

Figure 1: Generic girder frontend photon beamline frontend for PETRAIII extension project.

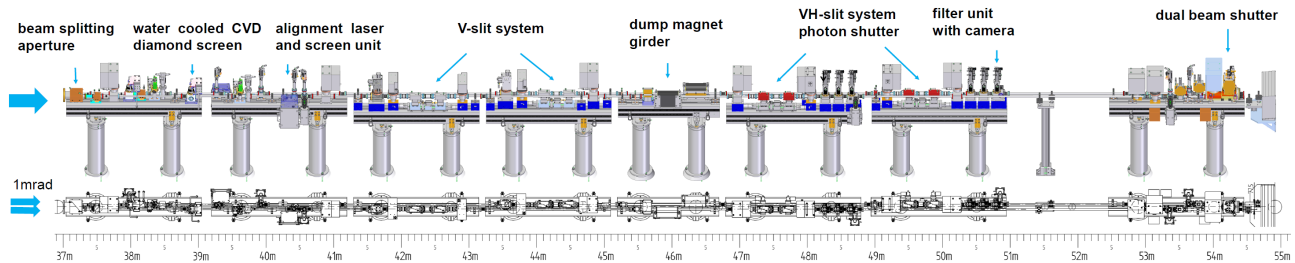

Figure 2: Side station photon beamline girder frontend P21.

unit in the optic hutch a CVD-diamond window is installed. Even at the highest beam current in the machine the camera readouts of these three screens allows an alignment of each white photon beam [6].

SIDE STATION BEAMLINE FRONTEND P21

The source of the two photon beams of the side station beamline are an 4 m in-vacuum undulator and a canted 2 m insertion device [2]. The two beams are guided to the beginning of the girder frontend in a common vacuum system with a rectangular tube. On the first girder the two beams are separated in different tubes. The distance at this point between both beams is 63 mm. The separation is performed by a new beam splitting aperture followed by a modified

aperture in each beamline. From this point on the components used are mostly standards. Because of the small distance between the two beams modifications of the housings are necessary. At the end of the frontend just before the 1.5 m thick storage ring shielding wall the beamlines have a distance of 77.5 mm. Just as in the generic approach a collimator and a beam shutter for each beamline is required at this point for the personal interlok. Because of the small distance a new dual beam shutter with integrated collimator is designed (see Fig. 3). The absorbers are moveable independently for each beam. Because of this dual beam shutter the beamlines share a common vacuum system. At the mostly generic components the vacuum system pumped individually the single beamlines. At several points a large pumping vessel connected the vacuum systems. This allows for fewer vacuum pumps and a shorter frontend (see Fig. 2). Right behind the concrete shielding wall a dual diagnostic unit separates the vacuum system for each beamline. Nevertheless eight specialized girders for the side station frontend are necessary because of the small distance and the high density of components.

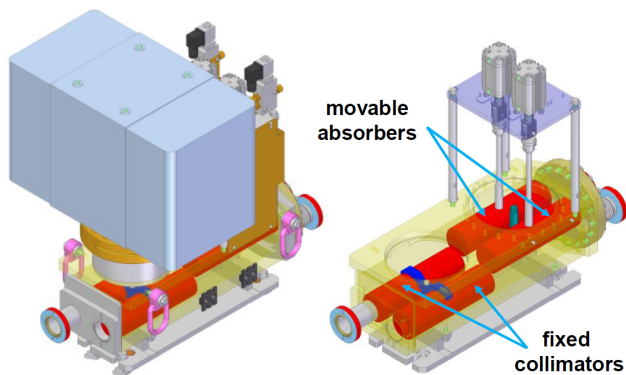

Figure 3: Dual beam shutter with integrated collimator for the side station frontend.

DAMPING WIGGLER BEAMLINE FRONTEND P61

The generic approach for the frontend design allows the reuse of three generic girders for the damping wiggler frontend (see Fig. 4). Only for the first girder a new arrangement is necessary. Because of the fixed gap operations of the 40 m long damping wiggler section a new setup of the mask system had to be designed. This system contains a new 3 mm x 2 mm rectangular aperture (see Fig. 5) followed by a new

Content from this work may be used under the terms of the CC BY 3.0 licence (© 2016). Any distribution of this work must maintain attribution to the author(s), title of the work, publisher, and DOI.

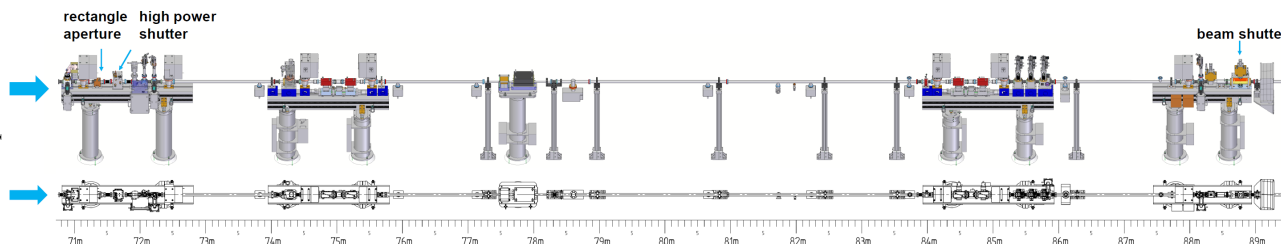

Figure 4: Damping wiggler beamline girder frontend P61.

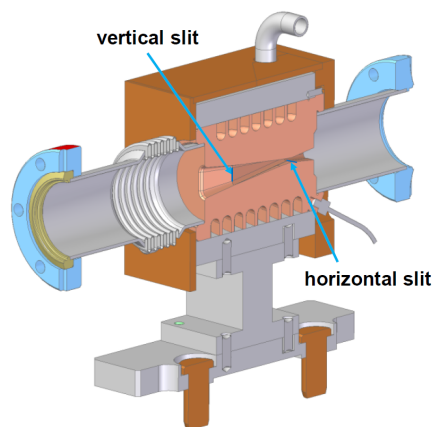

Figure 5: 3 mm x 2 mm rectangular aperture for the damping wiggler frontend with two slits in a row.

high power shutter which is based on a modified “slit blade” of the high power slit system. The effective 3 mm x 2 mm rectangular opening in the aperture is realized by Electrical discharge machining a vertical opening transitioning into a horizontal opening into a copper alloy¹ body.

CONCLUSION

The buildings and the tunnel sections with the concrete shielding are completed. PETRAIII resumed user operation in the Max von Laue experimental hall for the other 14

¹ Glidcop

photon beamlines in April 2015. Most of the new generic 20 mrad extension frontends are installed and commissioned for UHV, but not in use for photon beam. The modified straight sections will be installed at the end of 2016 and in 2017 and are currently in manufacturing. The work in the optic hutches and experimental hutches is continuing.

REFERENCES

- [1] W. Drube, M. Bieler, W.A. Caliebe, H. Schulte-Schrepping, J. Spengler, M. Tischer, R. Wanzenberg, “The PETRAIII extension”, *AIP Conf. Proc.* 1741, 020035 (2016), doi:10.1063/1.4952814
- [2] A. Schöps, P. Vagin, M. Tischer “Properties of the insertion devices for PETRA III and its extension”, *AIP Conf. Proc.* 1741, 020019 (2016); doi:10.1063/1.4952798.
- [3] M. Tischer, K. Balewski, A. Batrakov, I. Ilyin, D. Shichkov, A. Utkin, P. Vagin, P. Vobly, “Damping Wigglers at the PETRAIII light source”, *Proceedings of EPAC08*, Genoa, Italy, pp. 2317-2319.
- [4] U. Hahn, H.B. Peters, R. Röhlberger, H. Schulte-Schrepping, “The generic beamline concept of the PETRAIII undulator beamlines”, *AIP Conf. Proc.* 879, (2006), pp. 539-542.
- [5] M. Degenhardt, H.B. Peters, U. Hahn, J. Heuer, M. Hesse, H. Schulte-Schrepping, “Status of PETRAIII photon beamline frontends and optical systems”, *J.Phys.:Conf. Ser.* 425 0042005.
- [6] H. Schulte-Schrepping *et al.*, “Photon beamline frontends for the PETRA III extension project”, *AIP Conf. Proc.* 1741, 020041 (2016), doi:10.1063/1.4952820.