

Content from this work may be used under the terms of the CC BY 3.0 licence (© 2016). Any distribution of this work must maintain attribution to the author(s), title of the work, publisher, and DOI.

ENGINEERING CHALLENGES OF THE VMXi BEAMLINE

J. H. Kelly, Diamond Light Source, UK

Abstract

The in-situ Versatile Macromolecular Crystallography (VMXi) Beamline delivers a high flux density, taking data directly from crystallisation experiments within the plate, using a fully automated endstation. A double multilayer monochromator (DMM) was designed in-house to deliver a 60 fold increase in flux. Two robots and an automated load-lock pass the plates from the crystallisation storage units to the goniometer. A compact endstation was designed to accept the high flux and take data with acquisition times down to a millisecond. This paper gives an overview of the beamline layout and the interesting pieces of engineering design. The beamline is planned to take first user at the end of 2016.

INTRODUCTION

The in-situ Versatile Macromolecular Crystallography (VMXi) Beamline is effectively a new beamline which has been built through the original Diamond Phase one beamline I02. The new fully automated endstation has been designed to obviate the manipulation of individual crystals, preserving crystal integrity and giving diffraction feedback during as well as at the end of growth. A number of new custom components have been designed in-house for this unique beamline. This paper outlines some of the components engineered for the endstation.

The DMM has not been described here as it is the topic of other papers[1][2][3].

VMXi HUTCH

The VMXi hutch is a 4 mm thick fabricated steel construction. The structure is split into four parts. The chicanes are all at floor level. The upper shielding is split in to three rolling sections which may be manually pulled back for access. There are 24 leaded glass windows providing a very good view of the interior. A CAD image of the hutch next to the two plate storage units and external robot is given below (see Figs. 1 and 2).

SAMPLE LOADING AUTOMATION

When either a 20 or 4°C crystallisation plate is deemed ready for either screening or diffraction data capture, it will be ejected from the rear of the Formulatrix crystallisation storage units through a hatch. An industrial six axis robot mounted on a horizontal rail will then take the plate to the Endstation loadlock rotating it to the correct orientation on the way. The loadlock is a pneumatic device with a linear stage mounted upon a 180° rotation. The plate is retracted into the loadlock cylinder, rotated by 180° and driven out, presenting it to the internal gantry robot (See Fig. 3). The loadlock is radiation fail safe so it is not possible to break the radiation containment with a driven axis. It incorporates a bar code reader, a plate in-

position switch and stage limit switches to give feedback to the control system.

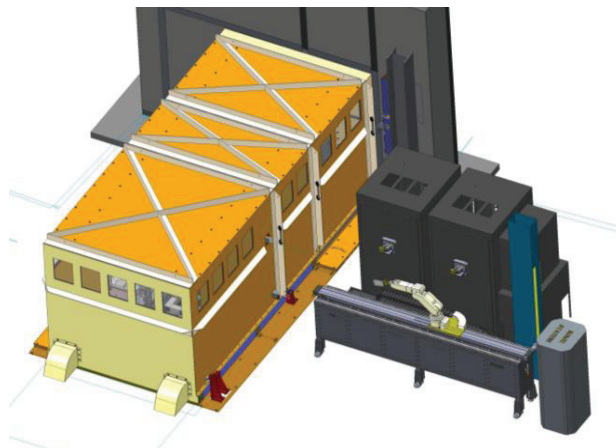

Figure 1: VMXi Hutch with the crystallisation units.

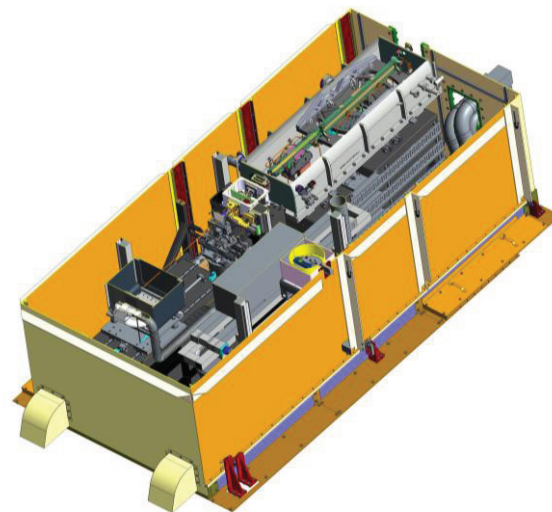

Figure 2: Section view of VMXi Hutch just above the beam path.

The plate will then be transferred into the internal storage buffer, sliding into the goniometer sample mount assembly. The journey from the temperature controlled crystallisation units to the temperature controlled internal storage will take less than 10s. For 4°C plates a thermal stability sleeve will be placed over the plate prior to being transferred onto the goniometer for data collection. The sleeve is designed to slow down the temperature rise of the 4°C plate in the 20°C environment. It was decided that active cooling on the goniometer would be likely to have a detrimental effect on the goniometer motion errors and thermal stability. The passive sleeve has been de-

signed to both insulate from the ambient air and provide a large heat capacity per unit mass. The sleeve body contains a phase change chemical which absorbs latent heat as it melts.

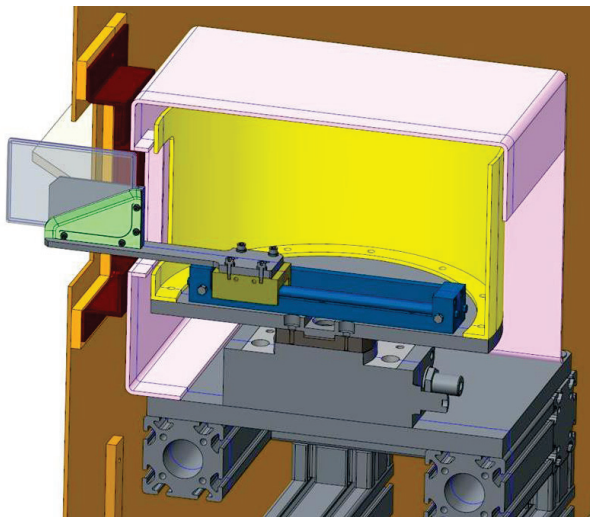

Figure 3: Hutch Loadlock; the plate is pulled into the yellow drum, which rotates within the pink shielding. The red & orange door may be rolled back to access the hutch.

The hutch gantry robot pneumatic gripper has two sets of fingers to hold either a plate or a sleeve with feedback to indicate which is held.

SAMPLE VIEWING SYSTEM

The on-axis vision system has been designed to give the optimum optical resolution without compromising flux. Either a high resolution objective, low resolution drilled lens or a He filled beam pipe can be driven in to position. The camera assembly will remain static with a three Vee kinematic mount providing the position repeatability rather than relying on the servo motion stages. The lens position repeatability will be key to the beamline performance because the visible and X-ray optics must remain coaxial. The samples will be automatically positioned using image pattern recognition. This compares the online image with the offline image used by the user to select the type and location of scan. An image of the mechanical assembly is given in Figure 4.

BEAM CONDITIONING ASSEMBLY

The beam conditioning assembly will be housed within a water cooled helium enclosure with a transparent lid. It will consist of attenuators, an X-BPM, a shutter/chopper and an I1 detector. The use of a He environment will provide convective cooling which is required for the motors and also the attenuators because the absorbed power could be > 2 W.

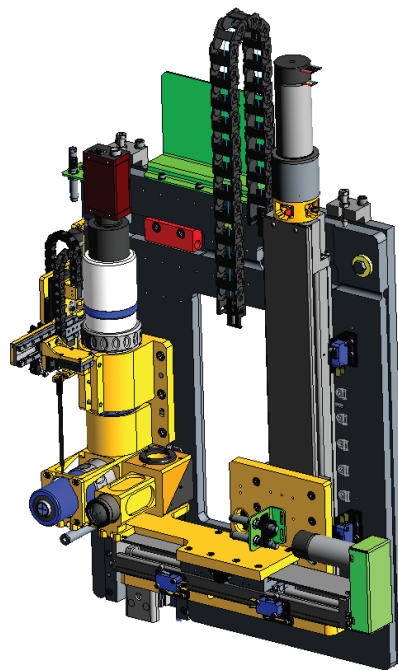

Figure 4: VMXi on-axis viewing and aperture assembly.

The three attenuator wheels will be mounted directly on stepper motor shafts. Absolute magnetic shaft encoders will be used for position feedback. The foils will be held in place by monolithic 3D printed flexure disks with numbers printed on the edge to give a visual position check through the lid. The Cividec single crystal diamond beam position monitor (BPM) will be mounted on an invar shaft directly through to the granite support for optimum stability. Cividec were chosen after a thorough diagnostics group performance study, for their good stability and linearity [4]. An image of the mechanical assembly is given in Figure 5.

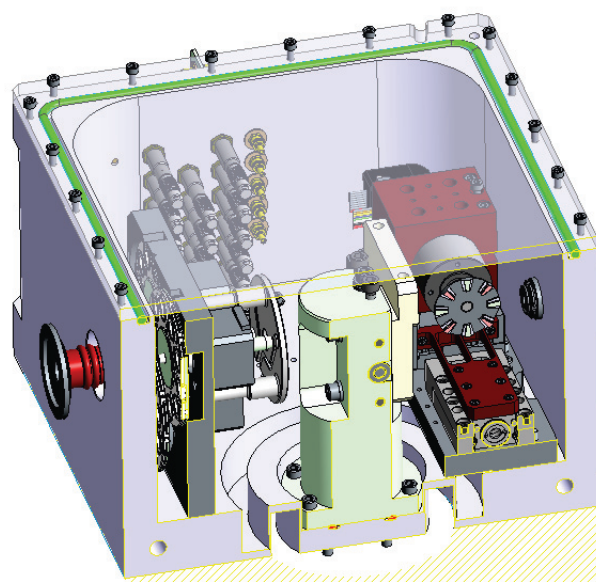

Figure 5: A section view of the beam conditioning assembly.

Content from this work may be used under the terms of the CC BY 3.0 licence (© 2016). Any distribution of this work must maintain attribution to the author(s), title of the work, publisher, and DOI.

A combined chopper/shutter was designed to provide shutter transit times $< 20 \mu\text{s}$ and the ability to chop the beam synchronised to the detector readout, minimising the sample dose. A low inertia chop disk with a three step pattern is mounted directly on the shaft of a servo motor. This has been tuned to perform a 22° step in less than 6 ms to open/close the shutter. The whole servo motor is mounted on a horizontal slide to drive it into the beam and select the chopper pattern. The balanced design creates negligible vibration and should provide long term reliability.

The I1 detector is a boron doped CVD diamond to give a similar fluorescence yield to YAG but with the transparency and thermal conductivity of diamond. A diode detects the fluorescence signal through the edge of the diamond so the whole assembly is contained within the wall of the Al box.

SAMPLE GONIOMETER

The sample goniometer has been designed in-house to position the crystallisation plates for data collection. The design consists of a very stiff ($11.5 \text{ Nm}/\mu\text{rad}$) air bearing to provide the omega rotation mounted with the rotary axis vertical. The axis of rotation will be driven coaxial with the X-ray using a custom crossed roller, harmonic drive horizontal X/Z table. On top of the airbearing will be a crossed roller horizontal Z stage, supporting a parallel kinematic X/Y stage. There is also a pneumatic tilt stage to rotate the plate by 20° . The main challenges for the design were that a large range of motion ($120 \times 80 \times 50 \text{ mm}$) is required to position any part of the sample area in the beam, combined with the local accuracy requirement of $< 0.5 \mu\text{m}$ over a sample volume of 2 mm^3 . A high beamline throughput required a high speed, whereas a sphere of confusion goal of $0.5 \mu\text{m}$ required high resolution and accuracy. The space envelope was severely restricted by the neighbouring components. The data capture will be both dynamic and static. The final goniometer design is currently being finalised and will be commissioned by the end of the year.

Goniometer Prototype Design

A prototype of the parallel kinematic stage was built to refine the design. A full prototype goniometer will be assembled onto the endstation to allow the other systems to be commissioned while the final goniometer is built and calibrated. The prototype shown below used a number of plastic 3D printed parts. This was chosen because of the fast turn around and the amplified deflection as compared to the final metallic parts. It is possible to see or feel the stiffness of the nylon structures and quickly iterate the design accordingly. This is more rapid than a detailed ANSYS structural study and gives a tangible impression of performance.

The design required a ball joint angular range beyond that available from commercial products ($\pm 35^\circ$). Novel leg joints were created by sitting a 440C stainless steel ball in a nest of three ceramic balls. High flux magnets were positioned between the balls to preload the joint.

This design provides a machine protection feature of disassembly rather than damage from a collision.

The leg supports were guided by two preloaded carriages and driven by a preloaded ball screw coupled directly to a servo motor. The stages separate use Renishaw™ readheads viewing the same central encoder scale.

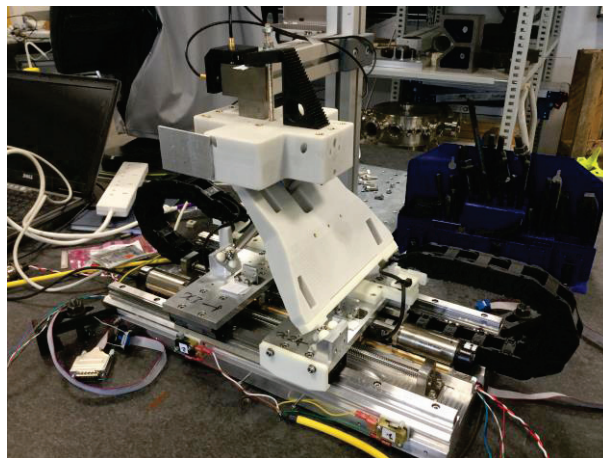

Figure 6: Prototype goniometer X/Y axes under test.

Goniometer Prototype Testing

The parallel kinematic assembly was tested in the lab as shown above in Figure 6, with orthogonal capacitance sensors. To drive right, both slides move right. To drive up, the slides move together. A number of automated scans were performed with varying motion parameters. An example plot of a 3 cycle scan is given below in Figure 7 with a zoomed-in view given in Figure 8. This data demonstrates position repeatability and cross talk between the virtual axes.

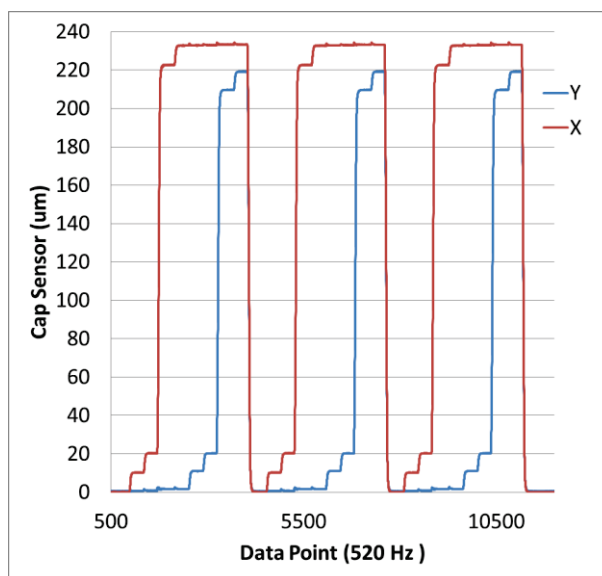

Figure 7: Prototype motion test data set full range,

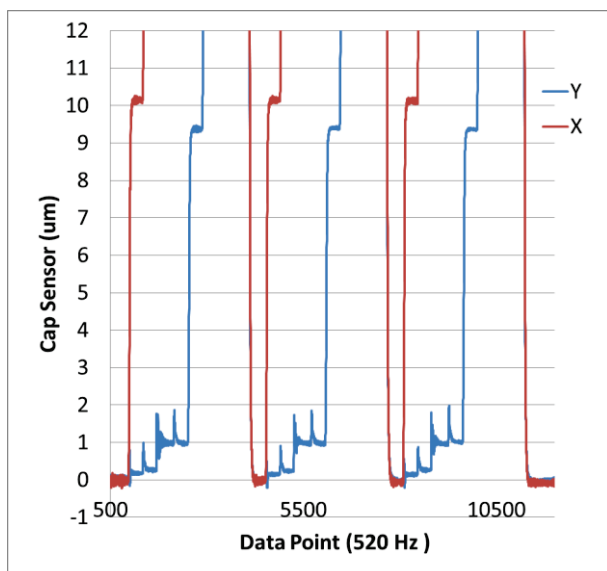

Figure 8: Prototype motion test data set zoom Y axis.

The stage exhibited < 200 nm bidirectional position repeatability even with repeated test moves of 20 mm. There were motion errors of ~ 1 μm as the stage accelerated and there were significant parasitic motions of $\sim 0.5\%$. The parasitic motions were expected because of the geometry errors. Alignment and length of the legs was set by the 3D printed parts. Interferometers have been integrated into the final design mounted as close to the sample as possible to minimise the parasitic motions and hence improve accuracy.

AIR CONDITIONING

A custom air conditioning system has been designed for the hutch using computational fluid dynamics (CFD). The two dominant criteria were that the sample plate temperature should be maintained $\pm 1^\circ\text{C}$ and that the mechanics should be stable to $\ll 0.5$ μm . The mechanical stability of the sample and the vision system is dictated by both air temperature and velocity. This is significantly complicated by the use of both 20°C and 4°C plates. The nominal hutch temperature will be $20 \pm 0.1^\circ\text{C}$ but within the hutch envelope is the internal storage with a 4°C section. The CFD was used to optimise duct locations with the aim of preventing the chilled air from moving past the sample viewing system.

CFD Results

A simplified model of the Endstation was created with a number of possible duct locations to allow easy re-configuration. Heat load power and location approximations were made. An integrated Al heat exchanger with fan product was chosen to be used with water cooled Peltier units. The reason for selection was to minimise design effort and to define the size and the flow parameters. The AC units will be located in the neighbouring hutch with the air ducted through where required. This will allow the use of the existing dehumidified air supply and will place the fans outside the sensitive area. The AC

Beam Lines

End Stations and Sample Environments

control racks and raw cooling water droppers are also located in the upstream hutch. Numerous configurations were run with the following conclusions:

- The air extract should be located close to the 4°C on the other side from the sample position to draw the cool air out of the hutch as shown in Figure 9.
- The use of a roof mounted air sock would require an unrealistic flow rate to disrupt the thermal stratification.
- The heat input to the hutch should be minimised. This will be achieved by ducting away the warm air from the 6M area detector and the fluorescence detector and by water cooling all the motors. An example image of thermal data is given in Figure 10.
- The addition of sealed volumes within the hutch envelope could both direct flow where required and reduce the volume of air to be actively cooled. An example of flow into the extract duct is presented in Figure 11.
- Any almost enclosed regions form a reservoir of stagnant warm air which could periodically flow giving detrimental effects.
- The use of an extra separate heat exchanger system to provide could provide a gentle flow of thermal stabilised air across the sample position creating a well-defined temperature.
- Significant air leaks to ambient can disrupt the desired flow.

The final design and some example CFD results are given below.

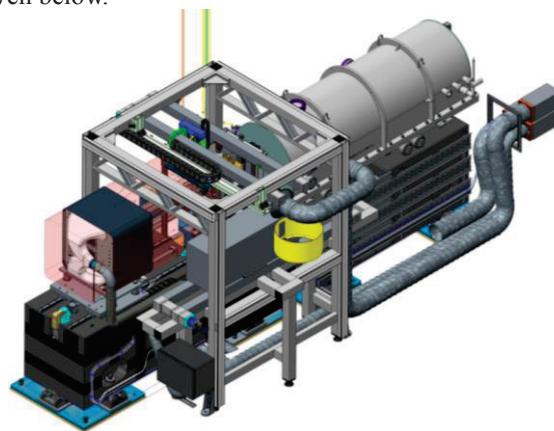

Figure 9: VMXi air conditioning design showing the detector extract and the ducting.

CONCLUSION

The VMXi beamline is currently being assembled and commissioned with first user planned for the end of 2016.

WECA07

307

Content from this work may be used under the terms of the CC BY 3.0 licence (© 2016). Any distribution of this work must maintain attribution to the author(s), title of the work, publisher, and DOI.

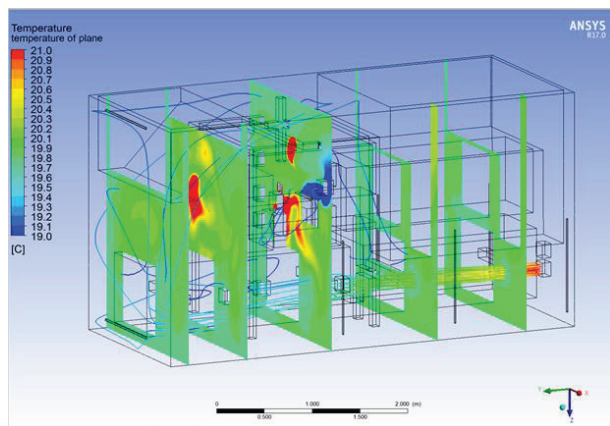

Figure 10: CFD data; the planes show temperature slices and flow streamline source is the main hutch AC inlet.

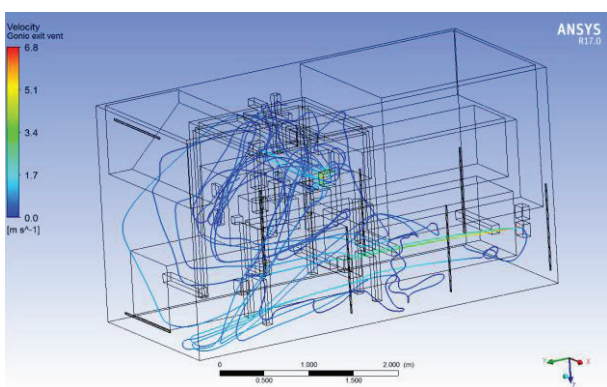

Figure 11: CFD data; flow streamlines show the paths to the main hutch AC outlet. The velocity is represented by the colour.

REFERENCES

- [1] D. Butler and J. Kelly, "Design of the Diamond Light Source DMM for the VMXi Beamline", presented at MEDSI'16, Barcelona, Spain, September 2016, paper FRBA03, this conference.
- [2] J. Kelly, "DMM Thermal Mechanical Design", presented at MEDSI'16, Barcelona, Spain, September 2016, paper TUPE01, this conference.
- [3] L. Alianelli, "Double Multilayer Monochromator for VMXi", Diamond Light Source, Harwell, UK, Rep. SCI-OPT-REP-0097, April 2014.
- [4] C. Bloomer et al., "An Experimental Evaluation of Monochromatic X-ray Beam Position Monitors at Diamond Light Source", presented at SRI Conf. (SRI 2015), New York, US, July 2015, paper WED-P-077, unpublished.