

THE GENERIC MIRROR CHAMBER FOR THE EUROPEAN XFEL

T. Noll^{1,2}, H. Sinn³, A. Trapp³

¹Max-Born-Institut Berlin, Germany, ²Helmholtz-Zentrum-Berlin, Germany
³European XFEL, Schenefeld, Germany

Abstract

For the high demanding requirements of the beamlines of the European XFEL [1] new mirror chambers were developed, designed and tested. A prototype contains the main features of all needed ten units which are tested extensively. The concept of the mirror chamber is a further development of our Cartesian parallel kinematics for X-ray optics in the UHV. The stiffness and vibration behaviour were further improved and the position resolution was increased compared to earlier implementations at HZB – Bessy II and Desy - Flash. For that the drives were redesigned and now feature a stroke of 100 mm with nanometre resolution.

INTRODUCTION

The new mirror chamber contains a mirror of 800 mm in length with adaptive shape compensation and an eutectic cooling. This mirror assembly has a dimension of 1000 mm x 150 mm x 250 mm (L x W x H). That large assembly requires a chamber of 600 mm in diameter and a length of 1800 mm (entry flange to exit flange). Both ends have doors for easy access to all inner components (s. Figure 1).

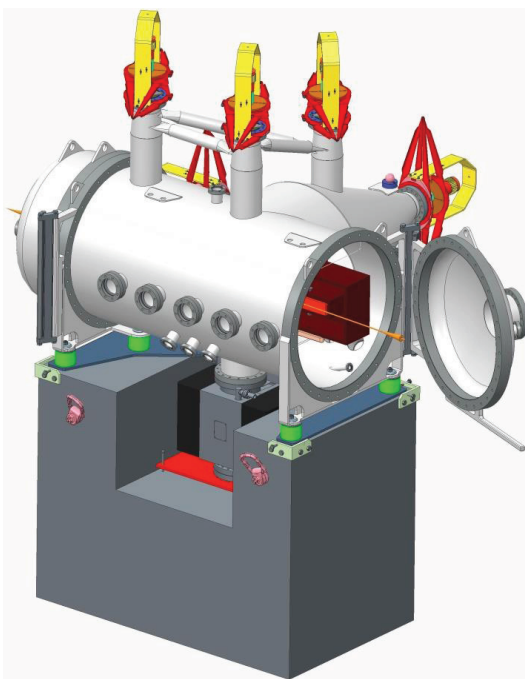

Figure 1: The mirror chamber with one open service flange.

Precision Mechanics
Nano-positioning

KINEMATIC CONCEPT

The support and alignment mechanics is in principle a six strut parallel kinematics with Cartesian orientation of the movements. This allows the highest possible precision and stability [2], [3], [4] (s. Figure 2).

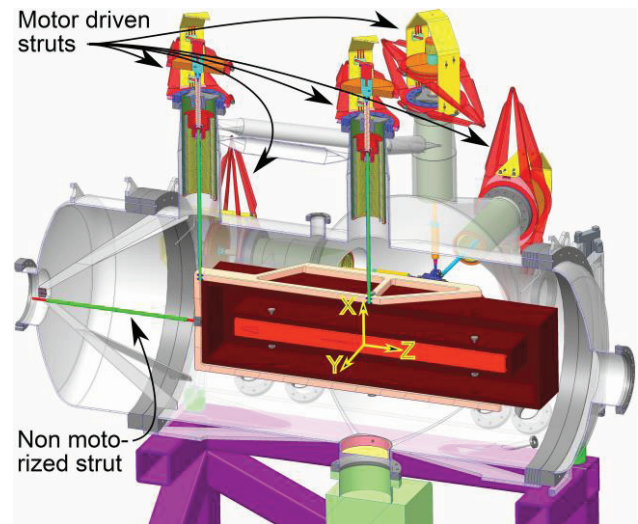

Figure 2: The cross section of the chamber gives a view at the topology of the struts.

The used six struts are the mechanical links between the mirror assembly and the flanges of the UHV-chamber. One of the struts has no motor and is not adjustable because it defines the position of the mirror along the light path which is not of interest for this application. Five of the six struts are motorized with stepper motors and lead screws.

DRIVE DEVELOPMENTS

For the X and Y translations stepper motor driven lead screws are used. For the rotations around X and Z the struts have additional piezo stacks embedded. That allows an even higher resolution and a higher motion dynamic than the stepper motor can deliver. (s. Figure 3).

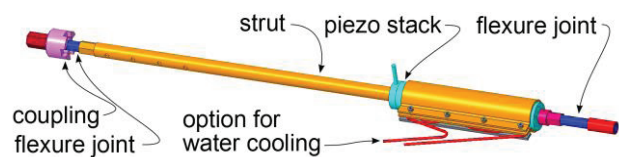

Figure 3: Strut with joints and piezo.

TUBA03
121

Content from this work may be used under the terms of the CC BY 3.0 licence (© 2016). Any distribution of this work must maintain attribution to the author(s), title of the work, publisher, and DOI.

The struts have flexure ball joints at each end which are made of stainless steel rope segments. They have a good combination of linear stiffness, bending and twisting elasticity, damping behaviour and durability [5], [6]. The struts are screwed into the thrust bearing of the lead screw.

The shaft of the motor gear head is directly attached to the lead screw [7] (s. Figure 4). The torque of the motor is supported by a flexure structure that allows the translation of the motor together with the lead screw while keeping the stator of the motor non-rotating while it translates together with the lead screw.

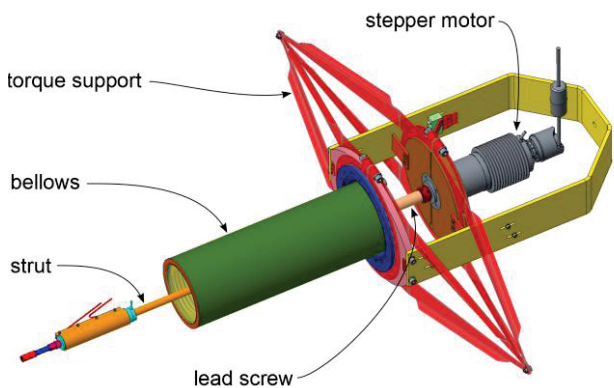

Figure 4: Dedicated feedthrough with strut and piezo.

The design of the lead screw driven linear motion feedthroughs uses a sliding bearing at the bottom of the lead screw (s. Figure 5). This non-rotatable part of the thrust bearing is welded to the bellows which also supports the torque caused by the sliding friction at the bottom of the lead screw.

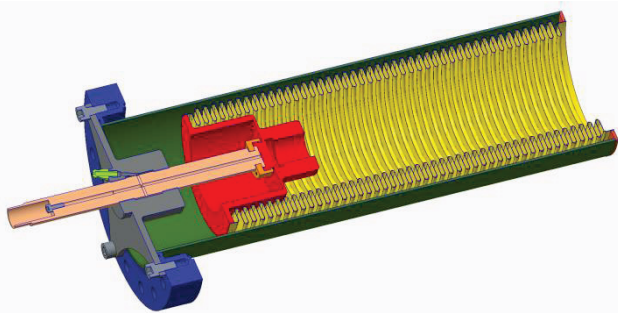

Figure 5: The sliding parts and the UHV-welding assembly.

The nut acts as linear guide way and motion transformer from rotation in to translation at the same time. Thus, we reduce the number of error sources and keep the assembly simple and mass and space saving. The sliding contacts of the thread and the axial bearing have a better reproducibility than the random errors of a ball screw and they are self-locking.

The lead screws have a diameter of 16 mm and a fine pitch of 1 mm. Because the sliding parts are in air they can – and need to be greased. Therefore a channel system

was designed which brings the lubricant from the grease nipple to each sliding contact pair without disassembling the unit (s. Figure 6).

The tight tolerances for the fine pitch thread of 1 mm are always a challenge for machining and can nevertheless cause seizing. Maybe for further applications a trapezoid thread combined with a higher transmission rate of the gear head of the stepper motor could make the system more durable.

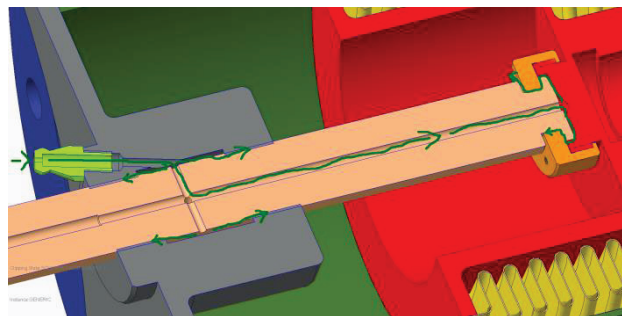

Figure 6: The greasing path for the sliding pairs.

The current setup contains a Phytron stepper motor with 200 steps per revolution and a gear head with a transmission ratio of 72:1. By the fine pitch of 1 mm we have a full step resolution of 70 nm over a distance of ± 50 mm. These simple and light weight assembly allows those ultra high precision linear motions and can be directly attached to the flange of the chamber.

UHV-CHAMBER

The UHV-chamber works as the fixed supporting structure for the drives and gives a rigid link to the base block made of granite and to the concrete floor. Because of its tubular shape and the large diameters the stiffness of the chamber is relatively high. Thereby the position of the flanges where the mirror is attached to is not very sensitive to changes of the air pressure. We calculated a deformation at the flange necks of max. 60 μm while applying air pressure (in the Creo Simulate and Ansys Software) (s. Figure 7).

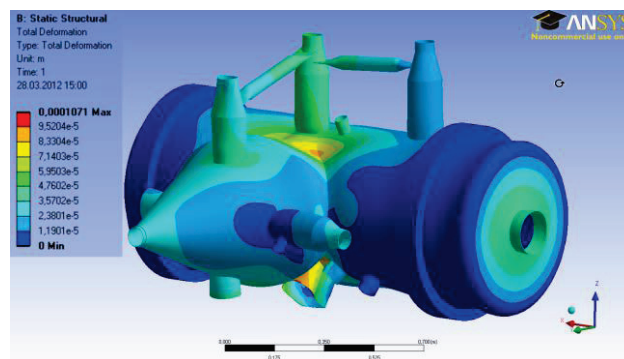

Figure 7: Deformation of the chamber under air pressure.

A second important characteristic of a mirror chamber is its vibrational behaviour. The tubular shape of the

chamber is also relatively light weight and stiff. These are the pre-conditions for high eigenfrequencies. Deduced from the CAD-design model a Finite Element Model was created.

The vibrational modes of the chamber could be optimized at a 1st eigenfrequency of 85 Hz. To reach this high stiffness we applied longitudinal connections of the chamber to the granite and cross links between the upper flanges. (s. Figure 8). We decided to have only 5 mm of wall thickness which causes a relatively low weight what increases the eigenfrequencies of the whole chamber on the granite base.

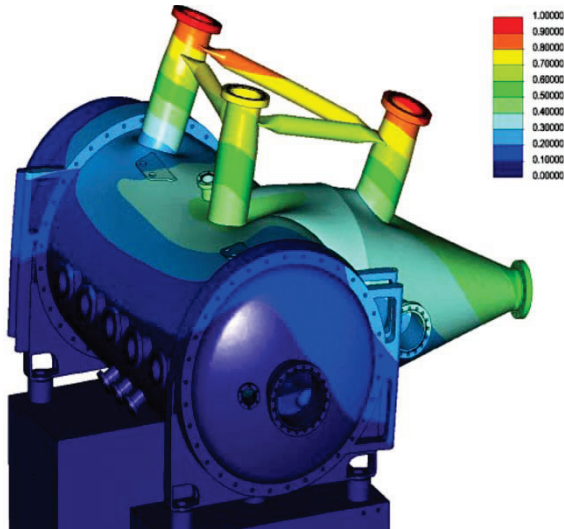

Figure 8: First eigenfrequency at 85 Hz (displacement in m).

At the starting point of the optimization of the vibrations we had low frequencies in a mode of vibrations in beam direction. It was caused by the relatively narrow legs of the chamber at the four corners which showed bending vibrations. This mode could completely eliminated by implementing additional connections to the granite base body (s. Figure 9).

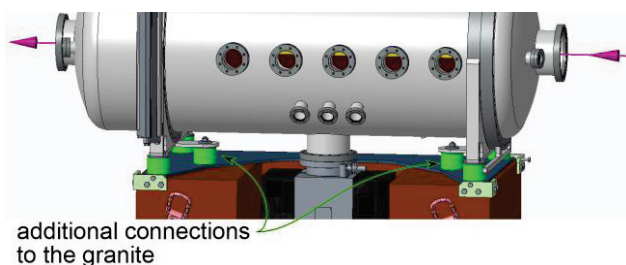

Figure 9: Connection of the chamber to the granite.

For the green pads shown in Figure 9 at the six legs we used the “ball head precision adjusters” from WASI [8]. These alignment screws allow the positioning and rigid fixing of the chamber in a range of about 5 to 10 μm , which is enough for the alignment of the chamber.

CONCLUSION

The generic mirror chamber for the European XFEL is a successful further development of the mirror chambers at Bessy II. The redesigned drives which are supporting and positioning the mirror have a long stroke of 100 mm with nm resolution. This stroke gives the opportunity to switch the mirror in and out of the beam instead of only using the drives for small alignments. There is still space to improve the properties like stroke and durability for further applications.

For the chamber and general set up we found a suitable compromise out of stiffness, weight, manufacturing costs and the functional features. Thus, the generic design can be the base for the required derivatives for each individual installation. The prototype is now for characterisation in the lab (s. Fig. 10).

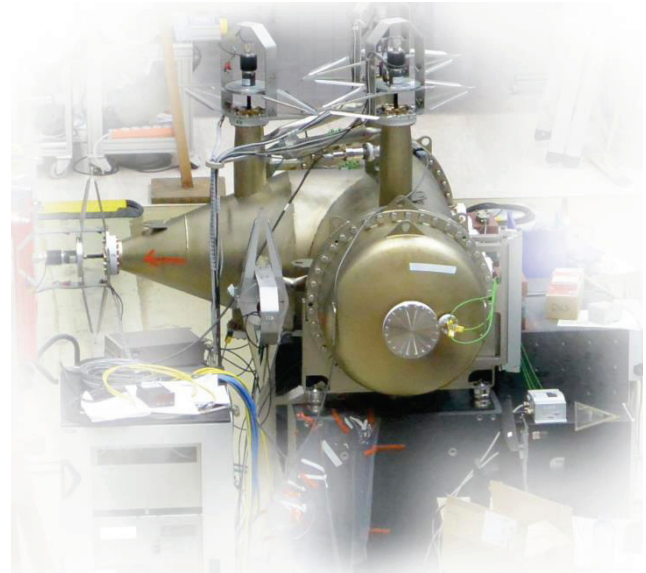

Figure 10: The prototype of the mirror chamber in the test lab.

REFERENCES

- [1] H. Sinn, et. al. „Technical Design Report: X-Ray Optics and Beam Transport” December 2012, XFEL.EU TR-2012-006, doi:10.3204/XFEL.EU/TR-2012-006.
- [2] T. Noll, et al. "Parallel kinematics for nanoscale Cartesian motions" Precision Engineering– journal of the international societies for precision engineering and nanotechnology Volume: 33 Issue: 3 Pg. 291-304 Published: JUL (2009).
- [3] Patent DE 100 42 801.0 „Flexibles Gelenk hoher axialer Steifigkeit“, T. Noll, W. Gudat, (2000).
- [4] Patent WO 02/16092 A1 „Device for Multi-Axis fine Adjustable Bearing of a Component“ T. Noll, W. Gudat, H. Lammert, (2001).
- [5] T. Noll „Flexure Joints of High Axial Stiffness“ Precision Engineering 26 (2002) Pg. 460-465.
- [6] Patent DE 100 42 801.0 „Flexibles Gelenk hoher axialer Steifigkeit“, T. Noll, W. Gudat, (2000).
- [7] Patent DE 200 15 988.7 „Spindelantrieb zur hochgenauen Positionierung eines linear zu verschiebenden Bauteils“, T. Noll, H. Lammert, W. Gudat, (2000).
- [8] Wasi, www.wasishop.de