

## THE SACLAY HIGH-CURRENT PROTON AND DEUTERON ECR SOURCE

P-Y Beauvais, O. Delferriere, A. France, R. Ferdinand, R. Gobin, J.M. Lagniel, P.A. Leroy (1)  
A. Farchi (2)

Commissariat à l'Energie Atomique

(1) DSM-GEGA, CEA Saclay, LNS 91191 Gif sur Yvette CEDEX, France

(2) DSM-DRFMC-SIAA, CEA Grenoble 38054 Grenoble CEDEX 9, France

### Abstract

High-current accelerators are studied for several years at CEA-Saclay for applications such as waste transmutation, tritium production or material irradiation. For these projects, the ion source is a key component because its performances determine the accelerator design. A CW Proton and Deuteron ECR Source has been constructed and is now under test. The aim is to reach a 100mA beam current at 95 keV with a rms normalized emittance better than  $0.2 \pi \cdot \text{mm} \cdot \text{mrad}$  and a very high reliability. In this paper, the source, the low energy beam transport and the beam diagnostics are described. First measurements of the source parameters and beam performances are presented.

### Introduction

The development of a new ECR source for proton and deuteron beam production is part of a considerably larger activity presently undergoing at CEA in the field of high intensity linear accelerators. This source is the first stage of the IPHI demonstration project. This accelerator will consist of an ECR source, a RFQ and a DTL up to 10 MeV. The production of high flux neutron beams for spallation reactions (TRISPAL), the international IFMIF program and nuclear waste treatment are main applications of this project.

It has been decided to develop a new source with the following requirements: 100 mA proton, 140 mA deuteron, 100 keV,  $0.2 \pi \cdot \text{mm} \cdot \text{mrad}$  rms normalized emittance and a 90% proton or deuteron fraction. The ECR source principle has been chosen for simplicity and reliability reasons as demonstrated by the Chalk River National Laboratory and the Los Alamos National Laboratory. Moreover, this kind of source shows no intrinsic lifetime limitations.

### The CEA-SACLAY Source

Experiences from several teams [1],[2],[3],[4],[5], have been used to design a High-Intensity Light-Ion Source (SILHI - Fig. 1).

The cylindrical plasma chamber is 100 mm length and 90 mm diameter. Both ends of this chamber are covered with boron nitride discs (2 mm thick). The proton beam is extracted through a 10 mm diameter aperture in the plasma electrode.

The magnetic field is produced by four coils independently tuned and positioned. These coils are magnetically shielded to reduce the total power dissipation

under 8 kW. This design has been calculated with the 3-D code Opera-3D [6].

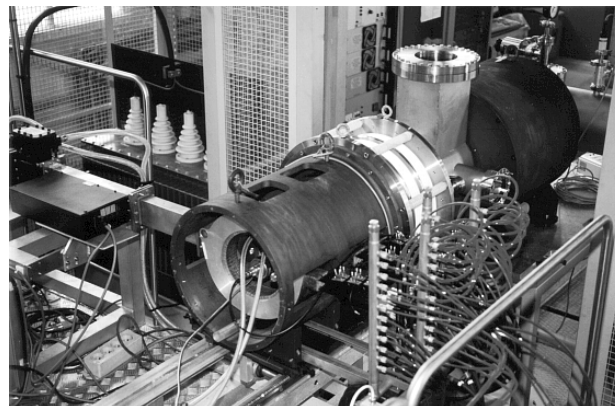

Figure 1: Picture of the SILHI source and first part of the LEBT.

The RF signal is produced by a 2.45 GHz, 1.2 kW magnetron source, and is fed into the source via standard rectangular waveguides (WR284, WR340). A three section ridged waveguide transition is placed at the plasma chamber entrance to enhance the axial RF field.

In order to be protected from backstreamed electrons, the RF quartz window is placed behind a water cooled bent section, in a high magnetic field area.

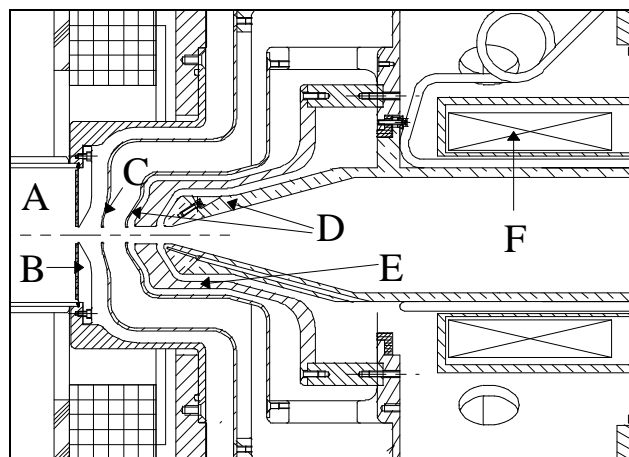

Figure 2: Schematic of the SILHI source extraction region. (A) plasma chamber, (B) plasma electrode, (C) intermediate electrode, (D) ground electrodes, (E) electron trap electrode and (F) DC Toroid.

The above components, including ancillaries, are grouped together on a 100 kV platform. The source is connected to the LEBT (Low Energy Beam Transport) via a 300 mm long HV column. An adjustable intermediate electrode is placed in the acceleration gap of the extraction system. The total system comprises five electrodes (figure 2). This design, optimized with the multi-particles code "Axcel"[7], minimizes the distortions in the phase-space distribution [8].

The actual LEBT is a one solenoid transport line. Simulations have been done with a 77%  $H^+$ , 15%  $H_2^+$  and 8%  $H_3^+$  mix. The 1800 Gauss magnetic field focuses the  $H^+$  beam on the Emittance Measurement Unit (EMU) which is not yet installed.

### Diagnostics

A set of different diagnostics is placed along the 2 m long LEBT in order to characterize the extracted beam (fig. 3).

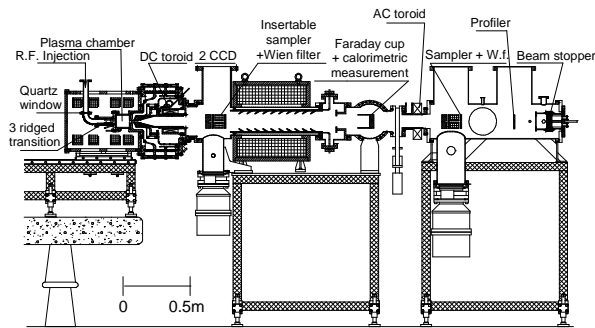

Figure 3 : Source and LEBT assembly.

### Current measurements.

A Bergoz DC toroid is located very close to the extraction system, around the last ground electrode (fig. 2). The bandwidth response ranges from DC to 4.2 kHz.

A copper beam stopper is designed to bear a  $0.8 \text{ kW.cm}^{-2}$  power density and 10 kW total power. It closes temporarily the LEBT 1.5 m behind the plasma electrode. This device is used both as Faraday cup and as calorimeter. In the future it will be replaced by an insertable beam stopper.

For noise measurement an AC toroid will be inserted 2 m after the extraction aperture. Up to now, the noise ratio is measured on the Faraday cup.

### Position and profile monitors

Two CCD cameras allow x and y profile measurements at the end of the accelerator column (60 cm after the extraction electrode) with a 0.15 mm resolution and a  $10 \times 10 \text{ cm}$  field. The sensitivity is 0.25 lux with a f/1.2 lens. FWHM, beam position and beam divergence are available from these camera images (fig. 4).

Close to the solenoid exit, a four sector ring gives a rough beam off-axis information and collects part of the contaminant species.

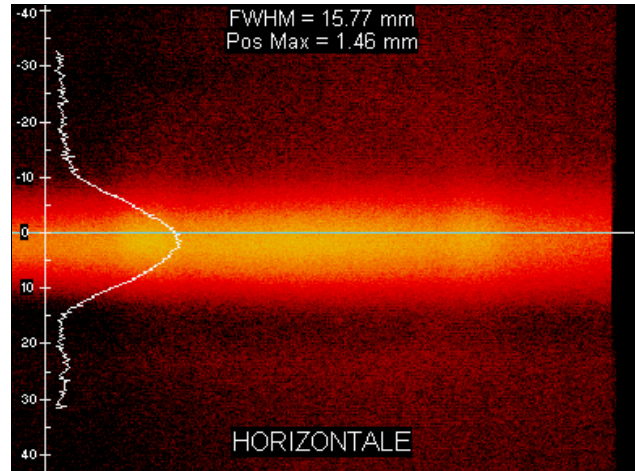

Figure 4: Video profile. Notice enlargement due to light parasitic reflection on back flange.

### Emittance Measurement Unit

In the near future, the EMU will be installed at 2.3 m from the source. It is composed of a sampler (0.2 mm square aperture) made in a water cooled beam stopper and a multiwire profile monitor 0.5 m forward. The pitch in the center of this profiler is  $350 \mu\text{m}$ . This unit will be moved across the beam by 2 stepping motors. Close to the sampler, a permanent magnet Wien filter will remove the contaminants ( $H_2^+$ , ...) in order to measure the proton only emittance.

### Species measurements

The beam proton fraction will be analyzed at the HV column exit by using the sampler and Wien filter which are parts of the EMU. The selected species current will be measured on the insertable Faraday cup.

A Residual Gas Analyzer will help in the water adjunction process which should enhance the proton production.

### Temperature measurements

Two thermocouples measure the temperature increase of the two grounded electrodes. These diagnostics are important to minimize the beam losses on the first electrodes during the extraction tuning.

### First results

The first plasma was obtained on July, 23. Only two weeks after, on August 7, a 46 mA total beam current at 70 keV was extracted. Table 1 shows the actual source parameters. The extracted current is measured by the DC toroid.

Figure 5 represents the regions where the magnetic field module is between 850 G and 900 G inside the four coils set. Calculation has been achieved with Opera-2d from Vector Fields. The light line delimits the plasma chamber ( $0 \leq z \leq 100 \text{ mm}$ , and  $R \leq 45 \text{ mm}$ ). It shows that the 875 G region is near the microwave injection area ( $z = 100 \text{ mm}$ ).

**Tableau 1:** Summary of the SILHI source requirements and present status.

Parameter	Req.	Status
Energy [keV]	95	70
Intermediate Elec. [kV]	65	47
Extracted Current [mA] (DC toroid)	111	46
RF forward power [W]	1200	295
Duty factor [%]	100	100
H2 Gas flow (sccm)	<10	2.7
Proton fraction [%]	90	to do
Beam noise [%]	±1	<1 (@25mA)
LEBT exit rms norm. emit. [π.mm.mrad]	0.2	to do

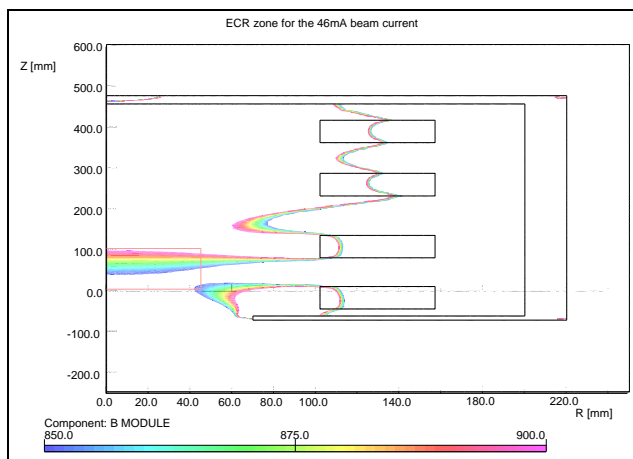
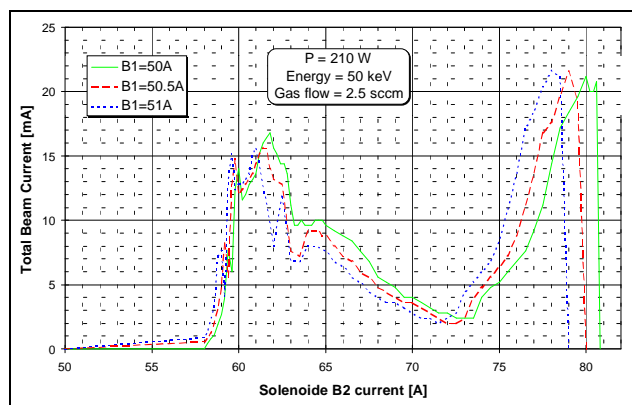

**Figure 5 :** Magnetic field calculation for the 46 mA extracted beam. The ECR area is located near the microwave injection.

During other experiments with total beam current of 25 mA (on DC toroid), the beam stopper calorimetric and electrical measurements give around 75% of beam transmission through the LEBT. This result gives a rough value of the proton fraction. The noise level has been measured on the Faraday cup with the same beam.

A complete mapping of the total extracted beam current as a function of B1 and B2 solenoids currents has been proceeded. These two coils define the magnetic field inside the plasma chamber. Thus the ECR zone can be moved everywhere inside the chamber. Figure 6 shows that two sets of coil currents give a maximum of extracted intensity.

Similar calculations to those shown on figure 5 indicates that the two intensity peaks on figure 6 coincide to the ECR zone located at both plasma chamber extremities. The left one corresponds to the microwave injection area and the right one to the plasma electrode region. An equivalent result has been achieved without boron nitride liners. The 46 mA total beam has been obtained with the ECR zone near the RF injection. The existence of the two peaks has been already observed by the CRNL team [2]. Moreover, two maximum of the extracted beam as a function of the magnetic field are observed at LANL [9].



**Figure 6:** Extracted beam total current on DC toroid versus axial magnetic field.

### Remarks

The first results look promising. Nevertheless, beam losses and electrons emitted from the grounded electrode in a sufficiently important number induce a too high electrodes temperature increase. New parts are under study and will greatly improve the power dissipation. The conditioning was not an issue, only few sparkdowns have been observed, even at nominal first or second gap voltage. No glow discharge has been noticed. But sparkdown results in frequent damages to controllers and power supplies located on the HV platform. Surge protections and new shieldings will be installed.

### Acknowledgments

The authors would like to thank D. Bogard, G. Charruau, J. Faure, P. Gros, F. Harrault, J-L. Jannin, F. Launay, P. Léaux, Y. Leroy, M. Woivre and all the other team members.

### References

- [1] A. Farchi et al., "First results of a high-current ECR proton source", International Conference on Ion Sources 1995, Whistler, Canada.
- [2] T. Taylor and J. Wills, "A high-current low-emittance dc ECR proton source", NIM A-309 (1991) 37-42.
- [3] T. Taylor and J. Mouris, "An advanced high-current low-emittance dc microwave proton source", N.I.M., A336 (1993) 1-5.
- [4] R.R. Stevens et al., "Injector design for high-current CW proton linacs", Particle Accelerator Conference 1993, Washington, U.S.A.
- [5] J.D. Sherman et al., "Microwave proton source development for a high-current linac injector", International Conference on Ion Sources 1995, Whistler, Canada.
- [6] Opera 3D, ©Vector Fields Limited. Oxford.
- [7] P. Spädtke, "Axcel-V 3.42", INP, D-65205 Wiesbaden, Germany.
- [8] A. France et al. "High current proton and deuteron ECR source developments at CEA", proceeding of EPAC96 (Barcelona).
- [9] J.D. Sherman et al. "Development of a 110 mA, 75 keV Proton Injector for High-Current, CW Linacs". This conference.