

## WEB-BASED CONTROL SYSTEM FOR 150-MW PULSE MODULATOR APPLICATION\*

S. D. Jang<sup>†</sup>, W. W. Lee, Y. G. Son, J. S. Oh, and M. H. Cho  
 Pohang Accelerator Laboratory, POSTECH  
 San-31, Hyoja-Dong, Pohang, Kyungbuk 790-784, S. KOREA

### Abstract

Total 12 units of high power klystron-modulator systems are under operation as a full energy injector linac for Pohang Light Source (PLS). The klystron-modulator control system has an important role for the stable operation to improve the availability of overall system performance of klystron-modulator system. The web-based klystron-modulator remote control system is under development using Ethernet (TCP/IP) network through Internet. The control system is consisted of a remote and a local controller. The remote control and on-line monitoring are realized on Human Machine Interface (HMI) based on Internet web browser application. The local device control system is configured using Programmable Logic Controller (PLC) system. This paper describes the architecture and operation experience of the klystron-modulator control system at test laboratory to realize web-based control system through Internet.

## 1 INTRODUCTION

Recently, significant advances in Internet and computer technology have made it possible to develop an Internet-based control and monitoring for industrial systems. The high power klystron-modulator control system has been upgraded with the internet-based technology. The proposed system architecture includes such features as control, measurement, networking, and reporting. This system enables users to quickly identify interlock status and make a convenient operation remotely of K&M systems to minimize system down time. The control system requires application software technologies such as LabVIEW, AppletVIEW, OLE for process control (OPC) server for control and monitoring based on the web. As a first stage, we applied the web-based control system to HV processing of the electron gun assembly for a high-power prototype klystron that is under development in Pohang Accelerator Laboratory (PAL).

## 2 K&M SYSTEM

### 2.1 system overview

The high power klystron-modulator (K&M) system is a main pulse and microwave source for the PLS linac. The peak powers of the modulator and the klystron are 200 MW and 80 MW, respectively. Figure 1 shows a simplified circuit diagram of the K&M system.

The modulator can be divided into four major sections: a charging section, a discharging section, a pulse transformer tank, and a klystron load.

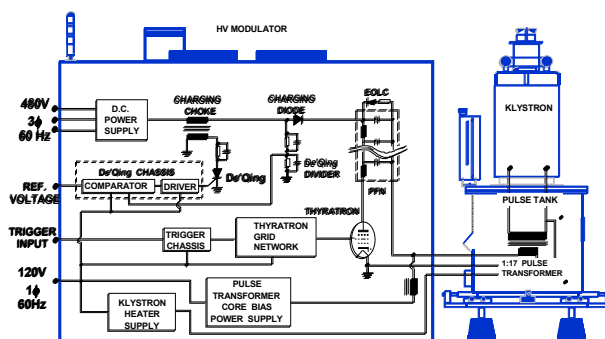

Figure 1: Simplified circuit diagram of the K&M system

The maximum DC HV at the primary of a pulse transformer is 25 kV. The pulse forming network (PFN) is resonantly charged from DC HV filter capacitor through the charging inductor and diode. Pulse-to-pulse beam voltage regulation is less than  $\pm 0.5\%$ . By adjusting inductance of each PFN section, we can precisely tune the flattop of the modulator output voltage pulse. The end of line clipper (EOLC) removes excessive negative voltage developed after discharge on the PFN capacitors as well as the thyatron. The klystron sits on the pulse tank top cover and is connected to the high voltage output of the pulse transformer. More detailed information of the K&M system is given in reference [1].

### 2.2 control sequence and signals

Figure 2 shows the simplified control sequence of the K&M control system.

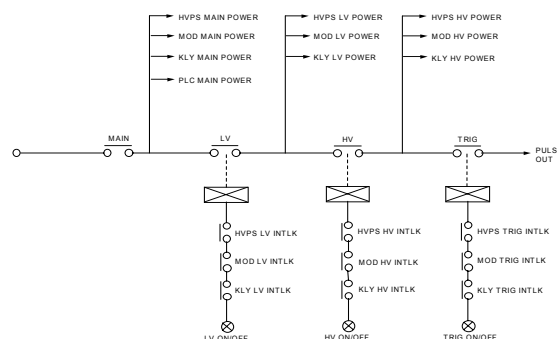

Figure 2: Simplified control sequence of the K&M system

\*Work supported by MOST.

<sup>†</sup>sdjang@postech.ac.kr

It can be divided into three major sections: HV power supply (HVPS), modulator (MOD), and klystron (KLY). Interlock signals also can be categorized as low voltage (LV), high voltage (HV), and trigger (TRIG) parts. It initially checks the interlock status of each device before DCHV turn-on. If all operating conditions are in green states, the K&M system can be ready to run sequentially.

Main signal types of the K&M system are listed in Table 1. There are an analog & digital control, and analog & digital monitoring signals. When a static interlock occurs, the controller completely turns off the DC HV and TRIG, and waits for operator's reset. In case of a dynamic interlock, it is recovered by itself if the fault condition is disappeared. Total number of signals is within 50 for the 150-MW K&M system.

Table 1: Main signal types of the K&M system

Type		Signal
Analog Control (1)		DCHV Reference
Digital Control (4)		LV On/Off, DCHV On/Off, Trigger On/Off, Reset
Analog Monitor (3)		DCHV Voltage, Klystron Vacuum, Load Vacuum
Digital Monitor	Dynamic Interlock (2)	EOLC Current, Klystron Vacuum, Load Vacuum
	Static Interlock (36)	Heater, Cooling, Door, Safety, etc
Digital Counter	Dynamic Interlock (2)	EOLC counter, Load Vacuum Counter
	Runtime (1)	DC HV Runtime

### 3 CONTROL SYSTEM ARCHITECTURE

#### 3.1 hardware configuration

The original K&M control system in the test laboratory is replaced with the PLC system and designed to improve the reliability, availability, and maintainability of the modulator. The developed control system has been implemented for the operation of the K&M system. It is consisted of a remote and a local controller. The remote control and on-line monitoring are realized on Human Machine Interface (HMI) based on Internet web browser application.

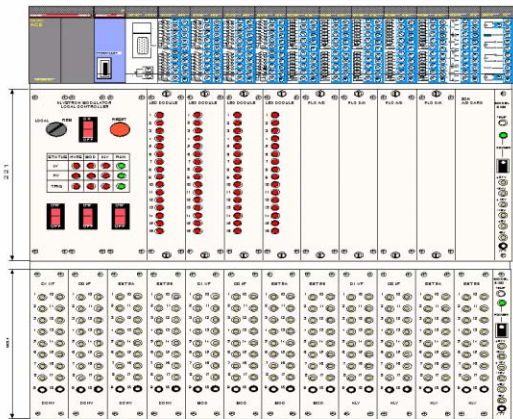

Figure 3: Local controller with PLC system and interface module for the K&M system

The local device control system is configured using PLC [2]. Figure 3 shows the local controller for klystron-modulator control system including PLC system. The local control panel contains the low and high voltage controls, process interlocks, and status monitoring and display. It is composed of the PLC interface, the operator interface, and the device interface using the NIM-Bin standards module mounted in a 19" rack. It takes advantage of compatibility and flexibility easily applicable to other system due to user-friendly patch type interface.

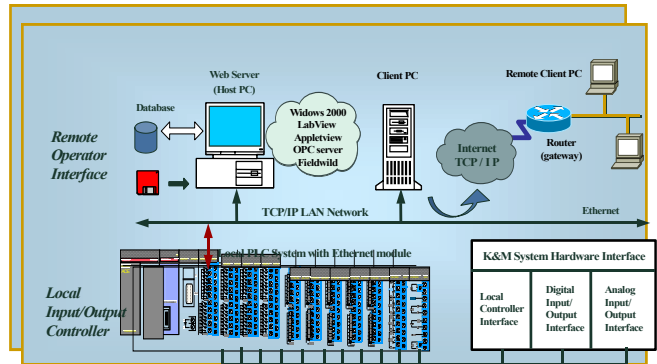

Figure 4: Hardware configuration for a web-based control

Figure 4 visualizes Overview of the hardware configuration for web-based control system using TCP/IP properties [3]. It is consisted of two layers including process control level (PLC) and remote operator interface level for MHI. The components necessary to develop this system are as follows: Windows 2000(OS), National Instruments LabVIEW, Java applet, OPC server, PLC (Yokogawa FA-M3) and the programming tool Fieldwild.

#### 3.2 software configuration

The proposed software architecture for a web-based control system is illustrated in figure 5.

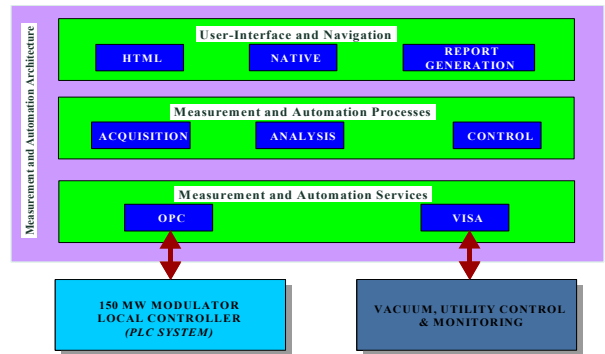

Figure 5: Proposed software architecture for a web-based control system

Applications necessary to create computer-based and networked measurement and automation systems are constructed using multiple software components, such as instrument drivers, software for front panel application.

LabVIEW is a graphical programming language that significantly simplifies programming and cuts down on development and debugging time, used primarily in Data Acquisition and Instrumentation control.

Java allows a user to build a client application with TCP/IP standard web protocols. It is well suited for writing robust web-based distributed applications because of its native multithreading, garbage collection, and exception handling techniques [4]. Standard Web browser such as Internet Explorer and Netscape can view Java applets. The AppletVIEW™ Toolkit uses the power and flexibility of Java and TCP/IP to allow you to control and access your virtual instrumentation system from anywhere on a network [5]. It requires no Java programming; you visually create an applet and then use AppletVIEW VIs on the LabVIEW side to communicate with the applet over a TCP/IP connection.

JNI (Java Native Interface) is the native programming interface for Java. It allows Java code that runs on a Java Virtual Machine (JVM) to operate with applications and libraries written in other languages. In order to talk to different local machine resources that developed in other language, a native resources accessing interface JNI is used our system.

The Virtual Instrumentation Software Architecture (VISA) is a comprehensive package for configuring, programming, and troubleshooting instrumentation systems comprised of VXI, VME, PXI, GPIB, and/or serial interfaces. It provides the interface between programming environments such as LabVIEW, etc.

The OPC (OLE (Object Linking Embedded) for Process Control) server as standard device interface enables to access the PLC data from supported client applications [6]. It supports YOKOGAWA PLC 'FA-M3(R)' with Ethernet module and CPU module. The OPC Interface includes OPC Data Access for real time communication and OPC Historical Data Access for logging data and OPC Alarm and Event.

#### 4 APPLICATION EXPERIENCES

Figure 1 shows main control panel of the K&M system for web-based remote control through web browser.

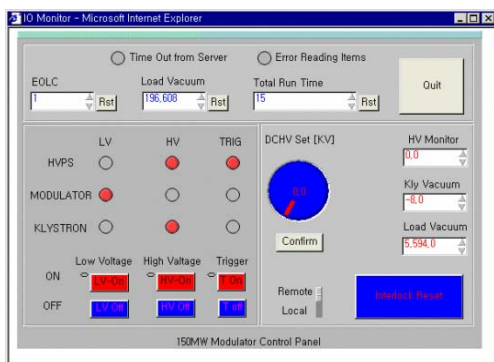

Figure 6: Main control panel through MS Explorer

Main control parameters for remote operation are as follows:

- LV on/off, HV on/off, Trigger on/off
- DCHV reference control & monitoring
- Vacuum level monitoring
- Interlock summary status

This system makes convenient access and operation to control and monitor test equipment on the Internet away from the test lab. It controls the K&M systems following the parameters selected by a system operator. Figure 7 shows the historical trend of DCHV, and Klystron Vacuum signals as an example.

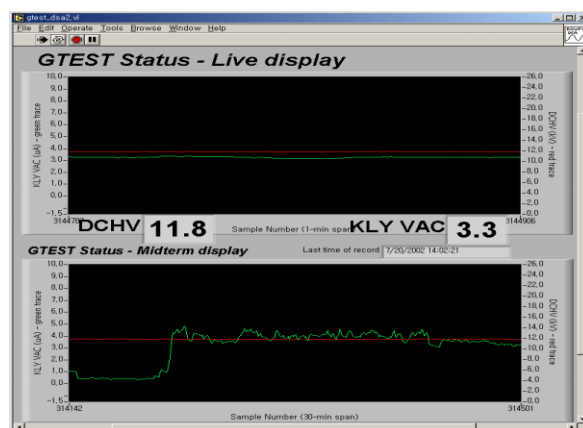

Figure 7: Historical real time trend view of HV&Vacuum signal

#### 5 SUMMARY

Distributed and real-time control systems play an important role in industries. We applied the web-based control system to HV processing of the electron gun assembly for a high-power prototype klystron that is under development in PAL. To control and monitor test equipment and physical devices remotely from anywhere on the Internet, a system operator opens the web browser and Java applet interface to remotely connect to the lab equipment. It will make easier to operators. The performance for HV processing time of the K&M system has been greatly improved using this system. The main advantage of this system is the easy access to control systems through the usual browser in Internet. However, there are some problems related to the common network security and access speed of transmitted data through an Internet connection.

#### 6 REFERENCES

- [1] S. H. Nam, J. S. Oh, M. H. Cho, and Namkung, "Prototype Pulse Modulator for High Power Klystron in PLS Linac," IEEE Conf. Records of the 20<sup>th</sup> Power Modulator Symp., Myrtle Beach, SC, 1992, pp 96-99.
- [2] <http://www.yokogawa.co.kr/production/product.asp>
- [3] <http://www.ietf.org/>
- [4] <http://java.sun.com/products/plugin>
- [5] <http://nacimiento.com/AppletVIEW/>
- [6] <http://www.faweb.net/us/opc>