

EMITTANCE MEASUREMENT FOR THE HEAVY-ION SOURCES AT HIMAC

T. Miyata[†], M. Yamamoto, K. Jincho, N. Sasaki, T. Miyoshi, S. Ishikawa, C. Kobayashi
 Accelerator Engineering Corporation (AEC), 2-13-1 Konakadai, 263-0043 Chiba-Inage, Japan
 H. Honma, Y. Sato

*National Institute of Radiological Sciences (NIRS), 4-9-1 Anagawa, 263-8555 Chiba-Inage, Japan

Abstract

At the HIMAC injector, two apparatuses for measuring the emittance were developed for the PIG and 18GHz-ECR ion sources. Particularly, the latter is a new and simple type, in which the 90° bending magnet sweeps the beam with a fixed slit. The length of the LEBT (low-energy beam transport) line between ion sources and RFQ linac is about 10m. The maximum intensity at the entrance of the RFQ has so far been limited to around 500 eμA and its transmission efficiency (η) through the LEBT to 40%, particularly for light ions. In order to clarify this limitation, an emittance measurement for the heavy-ion sources was proposed and the apparatus for the 18GHz-ECRIS was installed. The measurements were made for He²⁺, Ar⁸⁺ and Fe⁹⁺ beams. The result of Fe⁹⁺ (~100 eμA) was translated to that just upstream the RFQ by calculating the transfer matrix along the LEBT line, before being compared with the measured emittance value at the same place. There was a reasonable consistency both in the shape and area of two ellipses in phase space.

1 INTRODUCTION

There are three heavy-ion sources (PIGIS, 10GHz-ECRIS, 18GHz-ECRIS) in the HIMAC facility [1]. As can be seen in Fig.1, the extracted ion beams from these sources are accelerated to 8 keV/n and are fed through the low-energy beam transport (LEBT) line, before being injected into the RFQ linac [2]. The length of the LEBT line is about 10m. When commissioning the HIMAC injector in 1992-1993, the parameters for LEBT were determined by assuming an emittance (ϵ) value based on a calculation in each source, and have so far been empirically improved in daily operation. We have not yet determined whether these parameters are optimized or not, regarding the transmission efficiency (η). The maximum intensity at the entrance of the RFQ has been limited to around 500 eμA and η to 40%, particularly for light ions, such as H⁺, H₂⁺, He¹⁺ and He²⁺ beams. Also, it is still questionable whether this limitation is due to the space-charge effect or the use of several electrostatic Q-lens in the LEBT line. In order to investigate these problems, two apparatuses for measuring ϵ were developed for the PIGIS and 18GHz-ECRIS. The former is a normal type with multi-slits and multi-wires (under installation), while the latter is a new and simple

type, in which the beam is swept by the 90° bending magnet with a fixed slit.

In this measurement, the beam axis moves from the center and has a certain angle to the center axis, thus requiring some corrections to exchange the measured data into real ϵ values.

The corrected ϵ is once translated to the value just upstream of the RFQ by calculating the transfer matrix along the LEBT line, before it is compared with the measured ϵ_{RFQ} at the same place. This article describes the design of the apparatus and corrections along with some preliminary results for He¹⁺, Ar⁸⁺ and Fe⁹⁺ beams from the 18GHz-ECRIS.

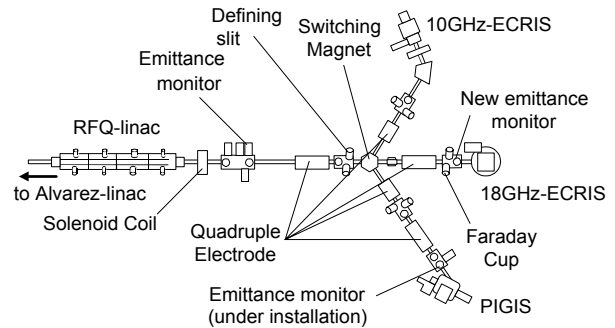

Figure 1: Layout of the LEBT line at HIMAC

2 APPARATUS AND METHOD

2.1 Apparatus

Figure 2 shows a layout of the apparatus (new emittance monitor) and the 18GHz-ECRIS. The vertically extracted beam from the source is at first focused by an Einzel lens before being accelerated to 8 keV/n at the acceleration gap (AG), then analyzed by the 90° bending magnet (BA). This magnet has also been used as an analyzer to measure the charge spectrum of the extracted ion beams from the 18GHz-ECRIS. The measurement of ϵ is basically made by using this BA, a fixed slit (S1) with a width of 0.7 mm, the movable (sweeping) slit (S2) with a width of 0.9 mm and a faradaycup (FC). The distance between S1 and S2 is 176.7 mm. Another apparatus has already been installed and well operated just upstream of the RFQ since 1992; hereafter, this apparatus will be used

[†]aec2g@nirs.go.jp

for comparison between two ϵ -values at both S1 and upstream of the RFQ. A combination of S1 and BA corresponds to the well-known multi-slit. This apparatus gives us the ϵ value only in the y-direction, though all elements in the 18GHz-ECRIS have a symmetrical configuration and the expected ϵ values should be the same in both the x- and y-directions.

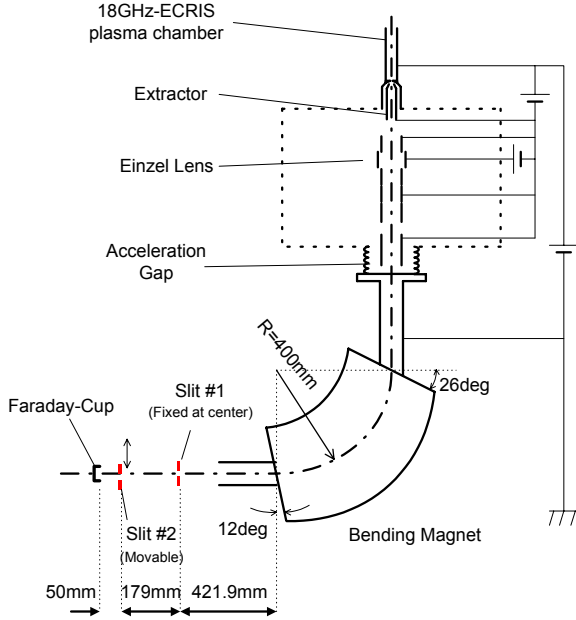

Figure 2: Layout of the new emittance monitor and the 18GHz-ECRIS

2.2 Method

In order to obtain a real ϵ value, the following corrections are necessary. One concerns the beam position (y). It is essential to know the relation (y/b) between the deviation of the beam position (y) and the corresponding change (b) in the magnetic field strength of the BA. This was made by measuring the center of the beam profile by using S2 and FC, while BA was set at a certain value; S2 was swept from -6.0 mm to $+6.0$ mm in steps of 1.0 mm. The deviation of the profile vs. b (y/b)_{S2} can thus be directly seen on an oscilloscope by using the signal from FC; the units are in [mm/Gauss]. The relation between (y/b)_{S1} at S1 and (y/b)_{S2} at S2 can be given by using the ratio (L_2/L_1) of the length between the center of BA and each slit(S1,S2) in the following expression:

$$\left(\frac{y}{b}\right)_{S1} = \left(\frac{y}{b}\right)_{S2} \times \left(\frac{L_2}{L_1}\right) \quad (1)$$

A typical procedure for the ϵ measurement is described in the following. Figure 3 shows a typical charge spectrum for the case of Fe ions produced by the 18GHz-ECRIS; normally, Fe⁹⁺ ions are used for acceleration. As can be

seen in Fig.3, we can know the ΔB_0 for Fe⁹⁺, which is the width of the magnetic field strength corresponding to the full beam of Fe⁹⁺. First, B_0 is set at a particular value within ΔB_0 ; then, S2 is swept from -6.0 to $+6.0$ mm, thus giving information about the distribution in both the intensity and angle of Fe⁹⁺ beams, as shown in Fig.4. Second, the setting of BA is changed so that the beam position can move by 1.0 mm at S1 according to the expression (1); then S2 is swept again in the same way. Such a measurement is repeated within the range of ΔB_0 , which gives the data on the relation between the intensity distribution and the angle distribution under a certain value of B_0 . Third, these data are translated to those corresponding to the position by multiplying the coefficient (y/b)_{S1}. The B_0 value, which corresponds the maximum intensity at FC without S1 and S2, should give $y=0$ (center of the beam).

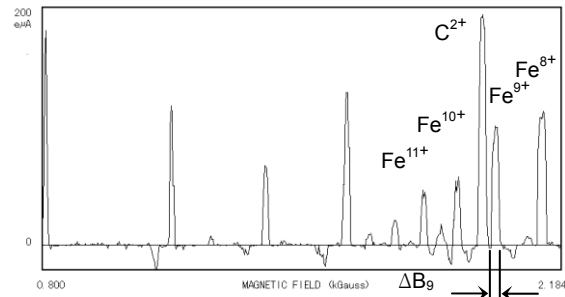

Figure 3: Charge spectrum in producing Fe ions with the 18GHz-ECRIS

The second correction concerns the beam angle (y'). During a measurement, the beam has a certain angle (ϕ) to the axis. As can also be seen in Fig.4, the relation between the beam angle and the position (y) is approximately expressed as

$$\Delta\phi = y/L_1 \quad (2)$$

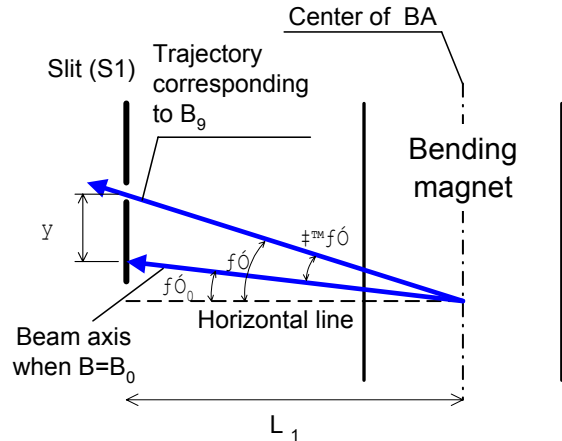

Figure 4: Correction method

3. RESULTS AND DISCUSSION

In order to verify the above-mentioned correction methods, the corrected (obtained) ϵ was compared with another measured ϵ_{RFQ} value just upstream of the RFQ, after a calculation using the transfer matrix along the LEBT line. The beam from 18GHz-ECRIS is normally defined by the slit (± 10 mm) located downstream of the switching magnet, before being injected into the RFQ. Figure 5 shows the measured ϵ_{RFQ} of Fe^{9+} beams ($47\pi mm \times mrad$) by a normal method with multi-slit and multi-wire. Figure 6 shows the measured and corrected ϵ ($100\pi mm \times mrad$) of Fe^{9+} in this work, and ellipse in Fig.7 (a) the calculated ϵ ($97\pi mm \times mrad$) at the defining slit. In this calculation, several points on the corrected phase ellipse of ϵ (Fig.6) are translated to those at the defining slit. Figure 7 (a); hatched area shows the calculated ϵ value ($60\pi mm \times mrad$), behind the defining slit (± 10 mm). This ϵ is further translated to that ($57\pi mm \times mrad$) at the emittance monitor just upstream of the RFQ, as shown in Fig.7 (b).

Comparing Fig.5 with Fig.7 (b), the shape of two ellipses and both areas are not very different. In conclusion, the new method for an emittance measurement is working well. The measurements were also carried out for He^{1+} (1.8 emA) and Ar^{8+} (200 emA), of which the areas are 141 and $94\pi mm \times mrad$, respectively. Generally speaking, the areas of these three cases (Fe^{9+} , He^{1+} , Ar^{8+}) are not very different, compared to our expectation. However, the best tuned beam regarding the intensity at FC has an angle (φ_0) of around -10 mrad to the axis in all cases, suggesting that the present parameters in the LEBT are somewhat incorrect or its alignment is not satisfactory. In this emittance measurement the magnetic field of BA is determined so that the maximum intensity can be obtained at FC behind S2. In daily operation including Fig.5, beam tuning is made so that the maximum intensity can be obtained at the entrance of the RFQ, in which the beam angle of zero mrad at FC is desirable.

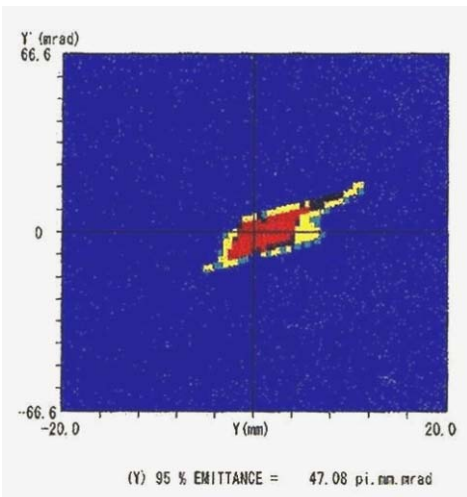

Figure 5: Measured ϵ_{RFQ} of Fe^{9+} beam

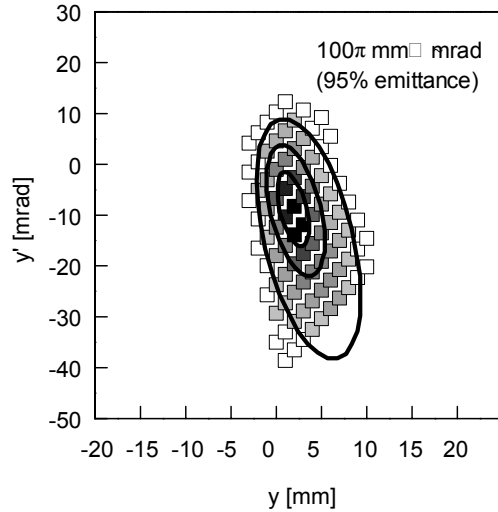

Figure 6: Measured and corrected ϵ at S1.

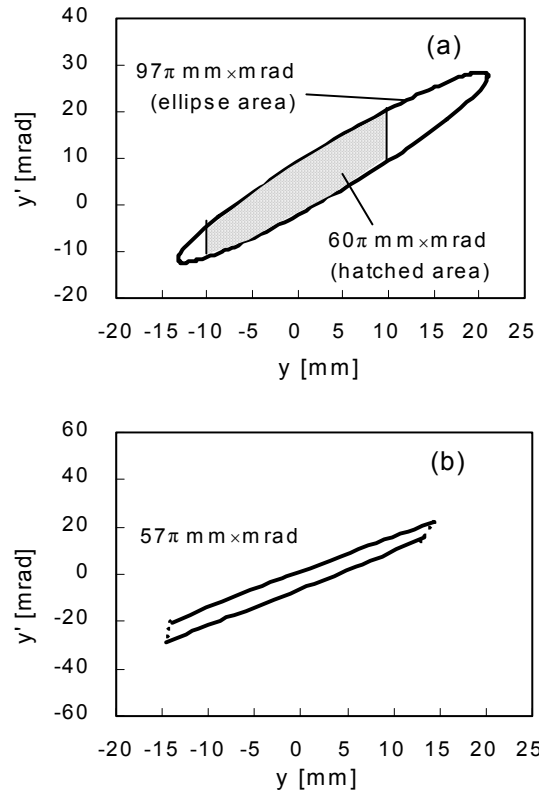

Figure 7: Calculated ϵ values: (a) ellipse by solid line shows before defined at the defining slit, and the hatched area after defined; (b) ϵ just upstream of RFQ.

4. REFERENCES

- [1] A. Kitagawa *et al*, Status of ion sources for the heavy ion medical accelerator HIMAC, Rev. Sci. Instrum. 67 (1996) 962.
- [2] S. Yamada *et al*, Present status of the HIMAC Injector, Proc. 94 Linac Conf. Vol.2 (1994) 768.