

EXPERIMENTAL STUDY OF SYSTEM FOR A SIMULTANEOUS BEND OF UNIDIRECTIONAL ELECTRON AND PROTON BEAMS

B.Yu. Bogdanovich, A.V. Nesterovich, A.N. Puchkov
Moscow Engineering Physics Institute (Technical University)
Kashirskoe sh. 31, Moscow, 115409 Russia

Abstract

It is known, that beams of positive ions and electrons are bent in different directions in transverse electric fields. The similar situation is observed in transverse magnetic fields. However in combined fields (transverse electrical and magnetic) there can be a situation, when unidirectional electron and positive-ion (proton) beams are bent in the same direction with an identical radius of curvature of a trajectory. The experimental studies of such deflector have been done. They have proved an opportunity of a practical realization of necessary conditions predicted theoretically. The results of the experiment are in a satisfactory agreement with the calculation. The tests have been performed at energy of particles up to 50 keV. They will be useful for design of systems, which provide scanning of an electron-proton beam in operations on radiative materials technology and at manufacture of hardware products of microelectronics.

1 INTRODUCTION

There is an interest to a problem of acceleration of the electron-ion beams. Linear accelerators with such beams which energy is more than several tens of MeV can be effectively used for nuclides transmutation by means of proton or X-rays received during electron bombarding of some target [1]. Linear accelerators with beams which energy is several MeV can be used as injectors in ion accelerators based on the collective methods [2]. Accelerators with beams which energy is less 1 MeV can be used for ion implantation with simultaneous neutralization of their positive charge by means of negative electron charge. It prevents microcircuits from discharge and damage [3].

In accelerators of electron-ion beams, there is a necessity to create a system for a simultaneous irradiation of a target by mixed electron-ion beams. This irradiation system has to provide a simultaneous bend of unidirectional electron and proton beams during a scanning of a target. In this paper, the theoretical background and results of an experimental study of such deflector are presented. This system [4] is based on a different character of an ion and electron bending in the $[\vec{E} \times \vec{B}]$ fields at different velocities of ions and electrons.

2 THEORETICAL ANALYSIS

In a general case, beams of positive ions and electrons are bent in different directions in transverse electric fields. The similar situation is observed in transverse magnetic fields. However in combined fields (transverse electrical and magnetic) there can be a situation, when unidirectional electron and positive-ion (proton) beams are bent in the same direction with an identical radius of curvature of a trajectory.

Figure 1 shows the case of a unidirectional motion of ion and electron with velocities \vec{v}_e and \vec{v}_i , respectively. The values of velocities provide the situation when a total force from the $\vec{E}_r \times \vec{B}_\perp$ fields for both beams is directed to the same point O .

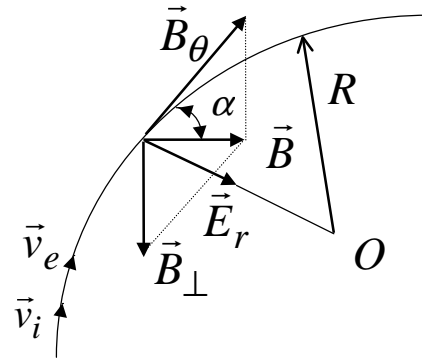

Figure 1: Vectors of electrical and magnetic fields and ion and electron velocities in the bending system.

In this case, the motion of ion is dominated by the electrical field \vec{E}_r and, the motion of electron is dominated by the magnetic field \vec{B}_\perp .

The analysis of particle motion and a derivation of conditions of a simultaneous bend of unidirectional beams can be done from the following equations

$$\vec{F}_{i,e}^{cp} = q_{i,e} \{ \vec{E} + [\vec{v}_{i,e} \times \vec{B}_\perp] \}, \quad (1)$$

$$|\vec{F}_{i,e}^{cf}| = m_{i,e} \vec{v}_{i,e}^2 R^{-1}, \quad (2)$$

where \vec{F}^{cp} and \vec{F}^{cf} are the centripetal and centrifugal forces, m is mass of a particle, and q is its charge, indexes i and e denote ion and electron, respectively, R is the radius of the trajectory curvature.

The electrical field \vec{E}_r is directed to the center O at every point of the particle trajectory. At the condition $v_e > v_i$, the values of fields obey the equation

$$E_r = \frac{v_e v_i}{R|v_e - v_i|} \left(\frac{v_i}{\eta_i} + \frac{v_e}{\eta_e} \right), \quad (3)$$

$$B_{\perp} = \frac{1}{R|v_e - v_i|} \left(\frac{v_i^2}{\eta_i} + \frac{v_e^2}{\eta_e} \right), \quad (4)$$

and, at the condition $v_e < v_i$, they obey the equations

$$E_r = \frac{v_e v_i}{R(v_e + v_i)} \left| \frac{v_i}{\eta_i} - \frac{v_e}{\eta_e} \right|, \quad (5)$$

$$B_{\perp} = \frac{1}{R(v_e + v_i)} \left(\frac{v_i^2}{\eta_i} + \frac{v_e^2}{\eta_e} \right), \quad (6)$$

where η_i and η_e denote the ratio of mass to charge. B_{\perp} is the value of magnetic field component which is perpendicular to the plane of the particle circular trajectory.

To provide focusing of electron beam, there is an azimuth component of magnetic field \vec{B}_{θ} in a vicinity of electron trajectory. It has a tangent direction to electron trajectory (see Fig.1). The total magnetic field is the superposition of \vec{B}_{\perp} and \vec{B}_{θ} . The above equations (2-6) do not take into consideration \vec{B}_{θ} .

Since the longitudinal velocities of particles are much more than thermal velocities, the crossed fields \vec{E}_r and \vec{B}_{θ} cause a centrifugal and electrical drift of particles, while a gradient drift coming from transverse velocities is negligible. In a general case, a centrifugal and electrical drift of particles results in a separation of electron and ion beams. However, a correct choice of values and directions of \vec{B}_{\perp} and \vec{E}_r , which provide a particle motion along the field \vec{B}_{θ} according to the equations (3-6), creates a such drift of electron beam near the vector \vec{B}_{θ} when electron and ion beams moves together without a separation.

It can be shown, the angle α defined as a ratio between \vec{B}_{\perp} and \vec{B}_{θ} is exactly equal to the angle defined as a ratio between a drift velocity parallel to \vec{B}_{\perp} and the longitudinal velocity v_e . The drift velocity parallel to \vec{B}_{\perp} is the superposition of a drift velocities in electrical and

magnetic fields which are $v_e^{drE} = E_r/B_{\theta}$ and $v_e^{drB} = v_e^2/(\eta_e B_{\theta} R)$, respectively.

An analysis shows that at close values of velocities the necessary values of electrical and magnetic fields become too large. This method of bending is practically useful at a large difference of ion and electron velocities.

2 EXPERIMENTAL STUDY OF BENDING SYSTEM

Figure 2 shows a possible variant of device for a simultaneous bend of unidirectional electron and proton beams. It consists of two plates of the electrostatic deflector 1 placed in the circular vacuum chamber 2, the magnetic solenoid 3, electron gun 4, the collector of electron beam 5, the system making up the transverse magnetic field 6. The ion injector is not shown here.

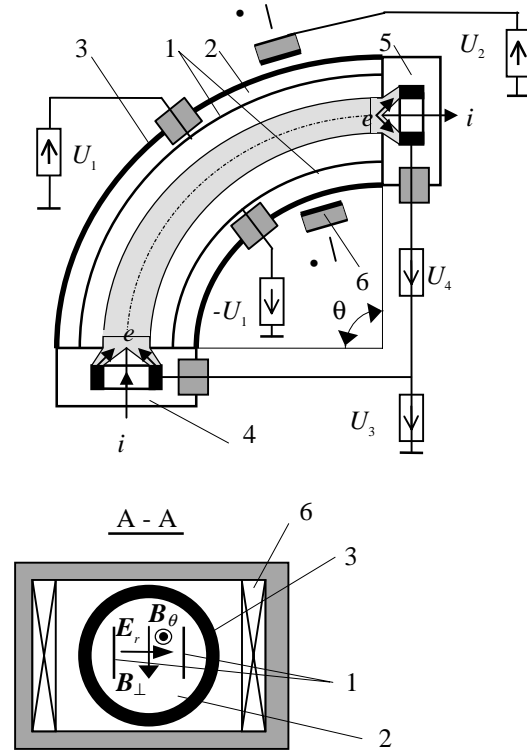

Figure 2: The system for a simultaneous bend of unidirectional electron and proton beams.

The electrodes 1 are concentric relatively to the center of beam bending. They are fed by the high voltage source V_1 in order to make up a radial electric field (\vec{E}_r) between electrodes. The magnetic solenoid 3 connected the current source V_2 creates the azimuthal magnetic field \vec{B}_{θ} . The magnetic field \vec{B}_{\perp} can be created by permanent magnets or electromagnets.

The electron gun 4 and the collector of electron beam 5 have circular apertures at the axis in order to pass ion

beam. The electron gun and collector are connected to the voltage source V_4 forming the system for a recuperation of an electron beam power. The cathode unit of electron gun is connected to a high voltage source V_4 . The cross-section view A-A illustrates the system making up the transverse magnetic field \vec{B}_\perp .

The table 1 presents an example of system parameters. $\beta_{e,i} = v_{e,i}/c$ denotes a relative particle velocity, and c is speed of light.

Table 1: The example of system parameters

$E_r, \text{kV/cm}$	β_e	β_i	B_\perp, T	R, m
50	0.5	0.05	0.03	0.5
	0.2	0.8	0.054	125

Due to a gradient drift there can be a shift of electron beam. This shift Δz is parallel to the rotation axis and can be evaluated by formulae [5]

$$\Delta z \approx \frac{\theta}{B_\theta} \frac{\beta_{e\perp}^2}{\beta_{e\theta} \sqrt{1 - \beta_e^2}}, \quad (7)$$

where a total velocity of electrons β_e is a superposition of two components $\beta_{e\theta}$ and $\beta_{e\perp}$, which are tangent and perpendicular to the vector of magnetic field \vec{B}_θ . Evaluations showed that even at unfavorable case with $\beta_{e\theta} = 0.8$ and $\beta_{e\perp} = 0.2$, the shift Δz is negligible (less than $\approx 0.1(\theta/B_\theta)$ mm).

Experimental tests to prove a possibility of simultaneous bend of electron and ion beams have been done on the setup shown in Fig.3. This setup is based on electron-ion injector described elsewhere [6].

The electrostatic deflector has the length of 8 cm. Magnetic shields are used in order to concentrate fields of bending magnet in a vicinity of fields of electrostatic deflector. Test has been performed using electron beam with energy of 50keV and proton beam with energy of 45 keV. The strength of magnetic field is 50G and strength of electric field is up to 1 kV/cm. The radius of beam bending is 30 cm. Beam current is measured by multi-collector Faraday cup. The experimental tests have shown as a qualitative and a quantitative agreement (within 10%) with the above theoretical analysis. The trajectories of electron and ion beams have the same radii of the

curvature. Thus, detailed study of the system for a simultaneous bend of electron-ion beams has proved a possibility of its practical realization.

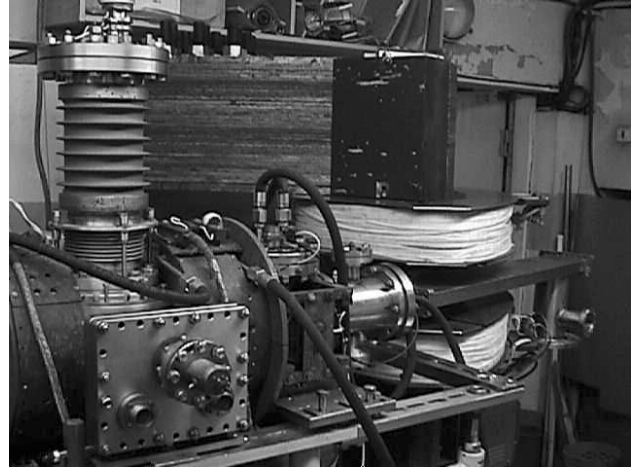

Figure 3: The photo of the experimental setup.

REFERENCES

- [1] E.Dikova, "Research and Development of Partitioning and Transmutation Technologies", Express Information, No. 19 (1599), 1989, pp.10-12 (in Russian).
- [2] N.A.Abramenko et al. "Linear resonance proton accelerator on energy 1 MeV with acceleration field generation by means of focusing electron beam", Questions of an atom science and technique. Series: "Phys. experim. Technique", no.2(23), pp.18-50, 1985 (in Russian).
- [3] M.D.Gabovich, N.V.Pleshivtsev, N.N.Semashko, "Ion and Atom Beams for Thermonuclear Synthesis and Technology", Moscow, E.A.P., 1986, pp.29-30 (in Russian).
- [4] A.V. Nesterovich "Method for a transportation of charged-particle beams", USSR author's invention certificate No. 1281144, 1985.
- [5] A.D.Frank-Kamenetskiy, "Plasma is a fourth state of matter", Moscow, Atomizdat, 1967 (in Russian).
- [6] A.V.Nesterovich and A.N.Puchkov, "Experimental Investigation Results on the Versatile Injector of Ion", to be published in Proc. EPAC 2000.