

ARRIVAL TIME STABILIZATION AT FLASH USING THE BUNCH ARRIVAL CORRECTOR CAVITY (BACCA)

B. Lautenschlager*, L. Butkowski, M. K. Czwalińska, B. Dursun, M. Hierholzer, S. Pfeiffer, H. Schlarb, C. Schmidt, Deutsches Elektronen-Synchrotron DESY, Hamburg, Germany

Abstract

For pump-probe and seeding experiments at free electron lasers, a femtosecond precise bunch arrival time stability is mandatory. To stabilize the arrival times a fast longitudinal intra bunch-train feedback (L-IBFB) using bunch arrival time monitors is applied. The electron bunch energy prior to a bunch compression chicane is modulated by superconducting radio frequency (SRF) cavities to compensate fast arrival time fluctuations of the subsequent bunches. A broadband normal conducting RF cavity was installed in front of the first bunch compression chicane at FLASH. The L-IBFB uses the normal conducting cavity for small but fast energy corrections together with the SRF cavities for larger and slower corrections. Current measurements show arrival time stabilities of the electron bunches towards 5 fs (rms) at the end of the linac, if the normal conducting cavity acts together with the SRF cavities in the L-IBFB system.

INTRODUCTION

The free-electron laser in Hamburg (FLASH) at DESY provides laser radiation in the range of soft X-rays with wavelengths down to 4.2 nm. The free-electron laser (FEL) operates in a 10 Hz pulsed mode. The SRF cavities accelerate the electron bunch-trains up to an electron beam energy of 1.25 GeV. Each bunch train can contain a maximum number of 800 bunches with a bunch repetition rate of 1 MHz. The length and repetition rates of the bunch-trains are variable and can be adapted for different experiments. The self-amplified spontaneous emission (SASE) process generates the laser radiation in the undulator section [1].

Femtosecond synchronization between external lasers and FEL pulses is required, e.g., for pump-probe experiments. To stabilize the arrival of FEL photon pulses, a longitudinal intra bunch-train feedback (L-IBFB) adjusts the electron bunch energies in front of a magnetic bunch compression chicane, which introduces an energy dependent path length. The bunch arrival time monitors (BAMs) measure the relative arrival times of each electron bunch, with a bunch-to-bunch spacing of up to 1 MHz, against a femtosecond stable optical reference system [2]. The laser based synchronization system is also used to precisely synchronize the experimental lasers [3].

The low-level radio frequency (LLRF) controller regulates the 1.3 GHz RF field of the SRF cavities in amplitude A and phase Φ . The LLRF controller provides different control strategies, e.g., a second order multiple-input multiple-output (MIMO) feedback controller to react within

a bunch train and a learning feedforward controller to minimize the repetitive control error from one bunch-train to another bunch-train. The RF field regulation typically reaches an amplitude stability of $\Delta A/A \approx 0.008\%$ and a phase stability of $\Delta \Phi \approx 0.007$ deg for the SRF cavities [4]. A combination of beam-based measurements, e.g., the arrival time, and the field information of the amplitude and phase is included in the LLRF control strategy and is used by the L-IBFB for the stabilization of the electron bunch arrival time [5, 6]. Since SRF cavities have typically only few 100 Hz bandwidth, a short normal conducting bunch arrival corrector cavity (BACCA) was installed to allow for small but fast energy corrections to push the arrival time stability towards 5 fs (rms).

LONGITUDINAL INTRA BUNCH-TRAIN FEEDBACK

Figure 1 shows a schematic of the FLASH facility with the SRF accelerator modules, the diagnostic units and the optical reference synchronisation system. The normal conducting cavity BACCA is located in front of the first magnetic bunch compression chicane (BC1) and after the third harmonic accelerator module ACC39. The beam-based feedback strategy at FLASH includes three feedback loops marked with green boxes in the schematic. The arrival time measurements of the BAMs after the two bunch compression chicanes, BAM.1 and BAM.2, are used to adjust the energy in front of a bunch compression chicane and thus stabilize the arrival time due to the energy dependent path length of the electron bunches through the chicane. The signal of the BAM (BAM.1) after BC1 is distributed to the LLRF system of ACC1 and BACCA. For slow arrival time corrections the RF field of the SRF module ACC1 is modulated and for fast corrections the RF field of BACCA. An additional beam-based feedback loop regulates the RF field of the SRF modules ACC2 and ACC3 to stabilize the arrival time after the second bunch compression chicane BC2, using the BAM after BC2 (BAM.2) as sensor. The accelerator modules after the second bunch compression chicane increase the beam energy but do not influence the arrival times for the FLASH1 beamline. The measured arrival time of the first BAM (BAM.0) shows the incoming arrival time, as well as the jitter and is not affected by the L-IBFB.

The bunch arrival time monitors provide the arrival time bunch-by-bunch with low latency. The main parts of a BAM are an RF pickup, an electro-optical modulator and a data acquisition unit. The electromagnetic field induced by the electron bunches is captured by four pickups. The optical synchronization reference system provides timing-stabilized

* bjoern.lautenschlager@desy.de

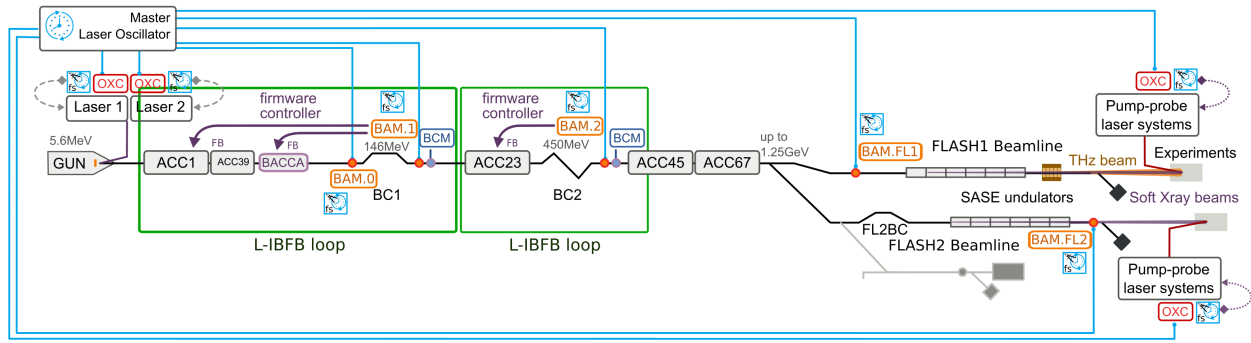

Figure 1: Scheme of FLASH with different L-IBFB locations, the superconducting modules, the normal conducting cavity BACCA, the diagnostic units and distribution of the optical synchronization system.

laser pulses for the electro-optical unit. The RF signal from the pickup modulates the reference laser pulses such that the strength of the modulation is proportional to the arrival time variations of the electron bunches. The developments and optimizations of the past years for laser based synchronization system, as well as for the BAMs has led to a resolution in the sub-10 femtosecond range [3, 7–9].

BACCA is a four cell normal conducting cavity and is installed between the third harmonic accelerator module (ACC39) and the first bunch compression chicane BC1. Figure 2 shows a picture of the cavity. The main design requirements are an energy modulation range of about ± 50 keV, a maximum feedback loop latency of 700 ns and a cavity half bandwidth of 500 kHz [10]. To keep the length of the cavity short, due to limited space in the beamline, the operation frequency of the cavity is 2.9972 GHz. Details about the installation, commissioning and first measurements with and without beam can be found in [11] and [12]. The read-out electronics of the BAMs and the LLRF control systems are based on the MicroTCA.4 standard. Real-time data processing of the L-IBFB is carried out on FPGAs of both, the diagnostic and the controller unit. The measured arrival times of the electron bunches are transmitted via an optical low-latency link to provide the data from the diagnostic unit to the controller with low latency.

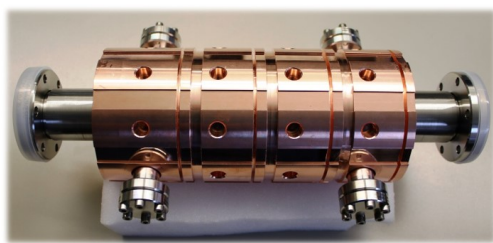

Figure 2: Picture of the bunch arrival corrector cavity [12].

RESULTS

All of the presented measurement results are related to the FLASH 1 beamline. The measurement data was taken with 400 bunches per bunch-train, a bunch charge of 0.4 nC

and a bunch-to-bunch repetition rate of 1 MHz. The repetition rate from one bunch-train to the next was 10 Hz. The L-IBFB was activated for the SRF module ACC1 together with BACCA and the SRF module ACC23.

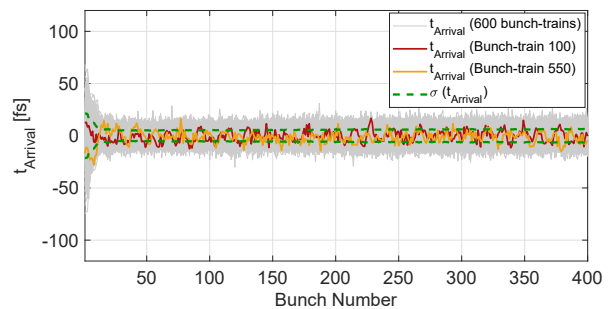

Figure 3: Mean free arrival time of BAM.2 The grey lines show the arrival time of 600 bunch-trains and the green dashed line the standard deviation $\sigma(t_{Arrival})$, with the L-IBFB at ACC1 together with BACCA and at ACC23.

Figure 3 shows the mean free arrival time of BAM.2 measured after the second chicane. The grey lines are the measured arrival time for 600 bunch trains. The two highlighted bunch-trains, 100 and 550, show as an example the measured arrival time of two single bunch-trains. The green dashed line represents the standard deviation of the 600 bunch-trains for every single bunch. Due to time delays in the system and a limited closed loop controller bandwidth, the first bunches cannot be controlled, such that these values are comparable to the RF field control only. In addition, the beginning of the bunch-trains gives an impression how the controller acts from bunch-to-bunch by reducing the peak-to-peak value of the arrival time (grey lines) significantly and thus minimizes the arrival time jitter (green dashed line). This becomes even clearer by the comparison of the arrival time measurements with and without the activated L-IBFB shown in Fig. 4.

The arrival time measurements of the BAM.2 with all three feedback loops activated (green dots) compared to the arrival time measured without the L-IBFB feedbacks (grey dots) shows the huge arrival time jitter improvement by a factor of 4 from 24 fs (rms, black dashes line) down to 5.8 fs (rms, green dashed line).

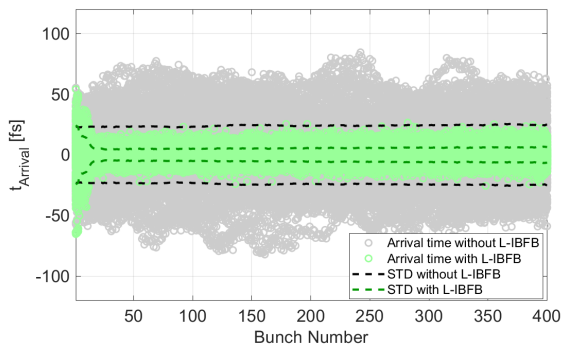

Figure 4: Mean free arrival time of BAM.2. The grey dots show the arrival time of 600 bunch-trains without the L-IBFB. The black solid line the standard deviation. The green dots show the arrival time with the L-IBFB at ACC1 together with BACCA and at ACC23. The green dashed line the standard deviation.

Figure 5 presents the changes of the arrival time jitter along the accelerator for the same set of data, which means the changes from BAM.0 to BAM.2. The incoming arrival jitter is ≈ 30 fs (rms) (BAM.0 - black solid line). The L-IBFB at the SRF module ACC1 together with BACCA pushes the arrival time jitter down to ≈ 8.5 fs (rms) (BAM.1 - blue solid line) after the first bunch compression chicane and with the additional L-IBFB at the SRF module ACC23 the arrival time jitter reaches the final value of ≈ 5.8 fs (rms) after the second bunch compression chicane.

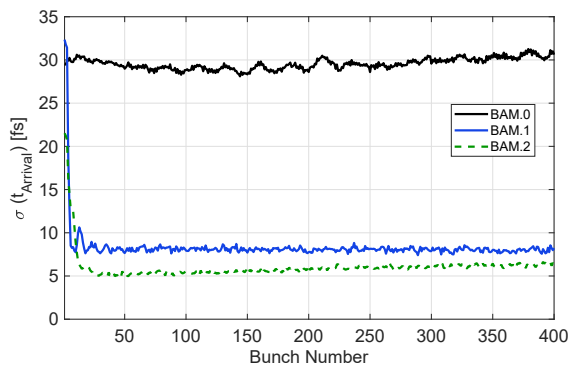

Figure 5: Standard deviation of the arrival time (600 bunch-trains) for the BAMs: BAM.0, BAM.1 and BAM.2. L-IBFB active at ACC1 together with BACCA and at ACC23.

CONCLUSION AND OUTLOOK

The results show that the arrival time stability can be improved in a significant manner by using the longitudinal intra bunch-train feedback at the SRF module ACC1, together with the fast feedback cavity BACCA and the additional feedback loop with the SRF module ACC23. The incoming arrival time jitter of 30 fs can be stabilized down to 5.8 fs after the second bunch compression chicane. The direct comparison of the arrival time jitter without the L-IBFB and with the three feedback loop activated shows a reduc-

tion from 24 fs (rms) to 5.8 fs (rms) after BC2, which is an improvement by a factor of 4.

One of the next steps is to use the bunch compression signals provided by the BCMs as an additional beam information for the longitudinal intra bunch-train feedback to stabilize the compression along the bunch-trains.

ACKNOWLEDGEMENTS

The authors would like to thank the entire Laser based synchronization team for very helpful discussions and the great support.

REFERENCES

- [1] FLASH, “Free-electron laser FLASH”, 2021. <http://flash.desy.de/>.
- [2] F. Löhl *et al.*, “Electron Bunch Timing with Femtosecond Precision in a Superconducting Free-Electron Laser”, *Phys. Rev. Lett.*, vol. 104, p. 144801, 2010. doi:10.1103/PhysRevLett.104.144801
- [3] S. Schulz *et al.*, “Femtosecond all-optical synchronization of an x-ray free-electron laser”, *Nat. Commun.*, vol. 6, pp. 5938–5949, 2015. doi:10.1038/ncomms6938
- [4] C. Schmidt *et al.*, “Recent Developments of the European XFEL LLRF System”, in *Proc. IPAC’13*, Shanghai, China, Jun. 2013, paper WEPME009, pp. 2941–2943.
- [5] S. Pfeiffer, “Symmetric grey box identification and distributed beam-based controller design for free-electron lasers”, Ph.D. thesis, TUHH, Hamburg, Germany, 2014.
- [6] S. Pfeiffer *et al.*, “Fast Feedback Strategies for Longitudinal Beam Stabilization”, in *Proc. IPAC’12*, New Orleans, LA, USA, May 2012, paper MOOAA03, pp. 26–28.
- [7] M. Viti *et al.*, “The Bunch Arrival Time Monitor at FLASH and European XFEL”, in *Proc. ICALEPCS’17*, Barcelona, Spain, Oct. 2017, pp. 701–705. doi:10.18429/JACoW-ICALEPCS2017-TUPHA125
- [8] A. Angelovski *et al.*, “Evaluation of the cone-shaped pickup performance for low charge sub-10 fs arrival-time measurements at free electron laser facilities”, *Phys. Rev. ST Accel. Beams*, vol. 18, p. 012801, 2015. doi:10.1103/PhysRevSTAB.18.012801
- [9] M. K. Czwalinna *et al.*, “New design of the 40 GHz bunch arrival time monitor using MTCA.4 electronics at FLASH and for the European XFEL”, in *Proc. IBIC’13*, Oxford, United Kingdom, Sep. 2013, paper WEPC31, pp. 749–752.
- [10] S. Pfeiffer, “Technical design report on ultrafast longitudinal feedback for FLASH”, CERN, Geneva, Switzerland, Rep. EuCARD2-Del-D13.1, 2014.
- [11] S. Pfeiffer *et al.*, “Longitudinal Intra-Train Beam-Based Feedback at FLASH”, in *Proc. FEL’19*, Hamburg, Germany, Aug. 2019, pp. 346–349. doi:10.18429/JACoW-FEL2019-WEP011
- [12] S. Pfeiffer *et al.*, “Status Update of the Fast Energy Corrector Cavity at FLASH”, in *Proc. LINAC’18*, Beijing, China, Sep. 2018, pp. 112–114. doi:10.18429/JACoW-LINAC2018-MOPO039