

# IMPROVEMENT OF MOTOR CONTROL SYSTEM IN J-PARC LINAC AND RCS

H. Takahashi<sup>†</sup>, A. Miura, Y. Sawabe, M. Yoshimoto,  
Japan Atomic Energy Agency, J-PARC Center, Tokai-mura, Japan  
T. Suzuki, M. Kawase,  
Mitsubishi Electric System & Service Co., Ltd, Tsukuba, Japan

## Abstract

The stepping motor control system used in the profile monitor and RCS collimator of J-PARC is configured by VME-based. Most of these pieces of control equipment are in use for more than 10 years. Therefore, countermeasures against aging of equipment are necessary. In addition, it is necessary to implement countermeasures against malfunction of the control system, which is thought to be caused by radiation.

In 2016, a malfunction occurred in the motor control system of the RCS collimator. Taking this as a starting point, we began developing a motor control system that can ensure equipment safety even if a malfunction occurs.

In this paper, we show the inference of the cause of this malfunction and present details of the developed high-safety motor control system.

## INTRODUCTION

Stepping motors are used in the driving systems of profile monitors, collimator, and other components in J-PARC Linac and RCS. In these driving systems, VME is mainly used as the control device for the stepping motor.

It has been more than 10 years since the start of J-PARC operation [1]. The VME used in the motor control system has been in operation for the same duration as well. Therefore, concerns about VME malfunction due to aging had started surfacing.

In RCS, the VME is installed in the sub-tunnel owing to limitation of cable length of the stepping motor. The sub-tunnel is located under the main-tunnel where the beam is accelerated, and these tunnels are separated by concrete wall (floor) with a thickness of 1 m to 2 m. Also, in one measurement after 300 kW beam operation for a week, the integrated neutron dose of sub-tunnel was about 0.4 mSv. Therefore, the possibility of VME malfunction due to radiation (for example, “single event effects” by low energy neutrons) cannot be denied.

Such a malfunction of the drive controller (VME) would not only hinder the safety and stable operation of the device but also damage the device. The main countermeasures against such malfunction are 1) do not let a malfunction occur and 2) secure safety in the case of a malfunction (prevent damage to equipment). For the control system, we decided to proceed with countermeasure 2). The development of the improved motor control system with high safety, which does not

damage the equipment in case of malfunction, will be described in the remainder of this paper.

## EXISTING MOTOR CONTROL SYSTEM

### Configuration

The configuration of the existing motor control system using VME is shown in Figure 1. The VME is connected to the motor driver and the hardware limit switches of the movable part. The ON/OFF operation of the brake of the stepping motor is not executed (The brake control cable is not connected.). Therefore, when the power supply is stopped due to a power failure, the movable part (absorber of collimator, wire of profile monitor) is attracted toward the center of the beam line.

### Investigation of VME Inoperability

The RCS ring collimator consists of six modules. Its motor control system has been in use for more than 10 years, and malfunction of VME was starting to become a concern. In the spring of 2016, remote control via the VME could not be performed normally in the motor control system. More specifically, although the operation to move absorbers by parameter setting was performed, the position monitor value did not change (any absorbers do not move). In addition, although the operation was performed several times, the position monitor value did not change. Then, when the collimator status was checked, it was found that damage accompanied with vacuum leak occurred in one module of the collimator [2].

It is not clear whether this damage to the collimator was caused by a VME malfunction. However, this possibility cannot be ruled out because remote operation could not be performed normally. Therefore, we built a test bench using the troubled VME (a CPU board, a motor control board) and attempted to reproduce the problem.

In the first such test we conducted, that is, “(i)

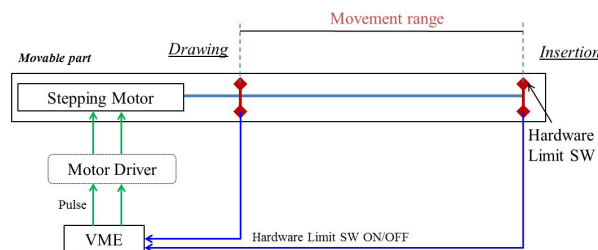

Figure 1: Configuration of existing system.

Content from this work may be used under the terms of the CC BY 3.0 licence (© 2018). Any distribution of this work must maintain attribution to the author(s), title of the work, publisher, and DOI.

<sup>†</sup> takahashi.hiroki@jaea.go.jp

Location: Non-radiation-controlled area, period: about 1 month,” the same problem could not be reproduced. Next, we conducted the test under the same environment in which the problem occurred, “(ii) Location: Sub-tunnel, period: about 1 month”, but the same problem could not be replicated.

### Failure of VME CPU Board

During test (ii), a completely different problem occurred with one profile monitor of RCS. In this case, there was no problem related to equipment monitoring (current position of wire, ON/OFF status of hardware limit switches), but a few operations could not be executed normally. This malfunction could not be solved by restarting the VME, and normal motor control system operation could be restored only by replacing the CPU board. Therefore, CPU failure was thought to have caused the malfunction. The motor control system of this monitor has been also used for more than 10 years.

### Inference of Cause

From the above two malfunctions and reproducibility tests, aging of the control equipment (VME) can be considered one of the causes of the problem. However, no problem was observed in the reproduction test on the test bench of the RCS collimator motor control system. Therefore, in addition to aging, we infer that an abnormality (single event effects) occurred in the semiconductor device owing to radiation (low energy neutron), and a malfunction occurred in the VME.

## IMPROVED MOTOR CONTROL SYSTEM

### Design Policy

Any malfunction in equipment having driving and movable parts causes beam loss. Therefore, avoiding such malfunctions is indispensable. The malfunction of the control device (VME) is thought to be caused by aging of the capacitor and the semiconductor element, or by abnormality in the semiconductor element induced by “single event effects”. Such a semiconductor problem may not only stop (freeze) the device but also cause unexpected operation. Therefore, the related countermeasure is very important.

Firstly, by updating the control devices, it is possible to cope with aging. As a countermeasure against the “single event effects,” it is conceivable to use a control device with high radiation resistance. However, the radiation environment in the RCS sub-tunnel will become more severe in the future owing to enhancement in the beam intensity at J-PARC (to 1 MW) [3]. Therefore, it is difficult to eliminate the malfunction caused by radiation, such as the “single event effects,” by using the device with high radiation resistance. In addition, the device with high radiation resistance is expensive.

Therefore, we decided to develop a highly safe motor control system that does not damage the equipment in the event of a malfunction. Then, to eliminate malfunction due to radiation such as the “single event effects,” we

proposed, designed, and developed a motor control system that combines safety mechanisms based on classical (hardwired) circuits without using semiconductor elements (using relays and etc.) with the control device.

### Configuration

First, a “Drive Part Stop Unit (DPSU),” which stops the stepping motor by using the hardware limit switches installed in the movable part was developed. The DPSU is a key device of this system, and this was designed and constructed without using any semiconductor elements. This design helps eliminate the possibility of malfunction of the unit owing to radiation. The details of the functions of DPSU are described in the next section.

Next, as the control device, the reliable FA specification PLC (Programmable Logic Controller, Yokogawa: FA-M3) was employed. The collimator and the profile monitor targeted by this motor control system are used (moved) during beam studies. Then, these components are in the stop (standby) state at the default position during normal accelerator operation. Therefore, when an abnormality occurs, it is desired that the control device be in the off (standby) state and the stepping motor be inoperative. The adopted PLC transits from the “run state” to the “standby state” when an abnormality occurs in its own modules. Based on this PLC function, the stepping motor is transited and maintained in an inoperative state, and safety can be ensured in the event of an abnormality. In this way, in terms of hardware, this system does not compromise safety in a radiation environment. Figure 2 shows the configuration of the proposed improved motor control system.

### Function

In consideration of the requirement of high safety, the improved motor control system has the following functions, (1) Emergency Stop (motor brake ON), (2) Pulse Cut, (3) Soft Limit and (4) Brake Mask (brake disable). An outline of these functions is shown in Figure 2, and the relationship between the hardware limit switch signals and the functions (1), (2), (4) is shown in Table 1.

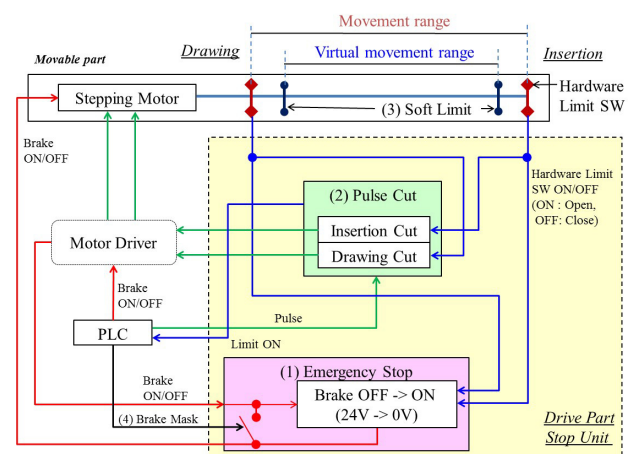

Figure 2: Configuration of improved system.

Table 1: Relationship between Limit SW and Functions

	Hardware limit SW	(1) Brake	(2) Pulse Cut
Normal operation	Insertion ON	ON	Insertion pulse CUT
	Drawing ON	ON	Drawing pulse CUT
(4) Brake mask enable	Insertion ON	OFF	Insertion pulse CUT (Drawing enable)
	Drawing ON	OFF	Drawing pulse CUT (Insertion enable)

“(1) Emergency Stop” is a function of DPSU. When the hardware limit switch ON signal (Open signal) is received, motor rotation is stopped forcibly by turning ON (0 V by fail safe) the brake of the stepping motor.

The “(2) Pulse Cut” function cuts a pulse signal which moves in the direction of the hardware limit switch in the ON signal, between the PLC and the stepping motor, when the limit switch is ON. In this way, higher safety is realized via double stopping functions of not only brake ON but also pulse cut.

(1) and (2) are the main functions of DPSU. By using these functions, even if the control equipment (PLC) always rotates the motor due to malfunction, damage to equipment by operation exceeding the movement range is prevented because it surely stops when the hardware limit switch is ON.

When the hardware limit switch is ON, function (1) and (2) work. That is, the system becomes in an abnormal state. Therefore, in the normal state, it is necessary to realize system operation in the range in which the hardware limit switch is not turned ON. Then, the “(3) Soft Limit” function sets two Soft Limits that define the virtual movement range (within the hardware limit switches, insertion, and drawing direction). By using this function, system operation without turning ON the hardware limit switch becomes possible. In addition, with this function, a highly secure system with the practically used limit switch (Soft Limit) and the equipment protection limit switch (hardware limit) is realized.

The “(4) Brake Mask” function is necessary to initialize the system to set “Soft Limit” or to release the hardware limit switch ON status. Without this function, the brake ON state owing to the hardware limit switch ON cannot be cancelled, and a deadlock occurs. Therefore, it is necessary to forcibly turn OFF the brake by this function. However, even if this function is temporarily used, equipment safety can be realized adequately by “(2) Pulse Cut”.

## PERFORMANCE OF IMPROVED MOTOR CONTROL SYSTEM

### Safety Function

The RCS collimator, Linac, and RCS profile monitors (each 6 monitors) have been improved and implemented into operation. There are not serious problems. However, with one RCS profile monitor, an abnormal status was

observed twice. In both cases, the PLC transitioned to the standby state, and it was confirmed that the PLC secured a safe state, as it is designed to do in the event of abnormality. These abnormalities are ascribed to the initial failure of the motor control module of the PLC because they did not occur after exchanging the corresponding module.

In addition, in this system, when the cabling of the hardware limit switches is not faulty, safety of the movable part is reliably secured by DPSU. Therefore, after improvement of the equipment, it was possible to conduct the test easily by assuming actual operation while securing safety.

### Operation

In stepping motor operation, the improved motor control system achieves the same operation as the existing system. In the operation for Linac beam studies, the measurement completed in 3 min with the existing system. However, with the improved system, the same measurement is completed in 3 min 30 s. In the improved system, communication between VME (IOC) and PLC (motor control device) is additionally needed. Therefore, the influence of LAN communication is considered to be stronger than that in the existing system. Communication links will be optimized in the future.

## CONCLUSION

To determine the causes of malfunctions of the motor control system of the RCS collimator and profile monitor, a reproducibility test was conducted. We could not determine a clear reason, but we inferred that these malfunctions were caused by aging or “single event effects”. Therefore, we developed an improved motor control system with high safety that does not damage the equipment in the event of a malfunction.

We installed the developed system in the RCS and Linac and confirmed that when a malfunction occurred, the system worked as designed. When the beam intensity of J-PARC is increased, it is expected that the effectiveness of this system will be more evident.

In the future, we plan to replace the existing system with the improved motor control system. Simultaneously, we will implement improvements based on the results of beam studies, and make this system to realize efficient measurement.

## REFERENCES

- [1] Y. Yamazaki (eds), “Accelerator Technical Design Report for J-PARC”, JAERI-Tech2003-044; KEK-Report2002-13.
- [2] K. Okabe, *et al.*, “A Failure Investigation of the Beam Collimator System in the J-PARC 3 GeV Rapid Cycling Synchrotron”, Proceedings of the 14th Annual Meeting of Particle Accelerator Society of Japan, Sapporo, Japan, August 2017.
- [3] M. Kinsho, “Status and Future Upgrade of J-PARC Accelerators”, in *Proc. of IPAC2016*, Busan, Korea, 2016, p.999.